



**GLOBAL TRENDS AND PROSPECTS
OF SOCIO-ECONOMIC DEVELOPMENT
OF UKRAINE**

Scientific monograph

Volume 1

Riga, Latvia

2022

UDK 33(477)(08)
G1543

Title: Global trends and prospects of socio-economic development of Ukraine

Subtitle: Scientific monograph

**Scientific editor and
project director:** Anita Jankovska

Authors: Yuliia Aleskerova, Volodimir Todosiichuk, Valeriia Vovk, Anastasiia Krasnoselska, Lyudmila Volontyr, Nadiia Hryshchuk, Svitlana Kovalchuk, Olena Martseniuk, Lyudmila Novitska, Oksana Ruda, Dina Tokarchuk, Oleksiy Tokarchuk, Inna Tomashuk, Ivan Tomashuk, Olena Tomchuk, Olha Khaietska, Oleksandr Shevchuk, Svitlana Kiporenko, Oleksandr Shevchuk, Olena Shevchuk, Viktor Dzis, Olena Dyachynska, Viktor Dubchak, Elvira Manzhos, Svitlana Bogatchuk, Yuri Boiko, Zorislav Makarov, Diana Bohatyrchuk, Kostiantin Levchuk, Elena Levchuk, Natalia Havryliuk

Publisher: Publishing House "Baltija Publishing", Riga, Latvia

Available from: <http://www.baltijapublishing.lv/omp/index.php/bp/catalog/book/205>

Year of issue: 2022

All rights reserved. No part of this book may be reprinted or reproduced or utilized in any form or by any electronic, mechanical, or other means, now known or hereafter invented, including photocopying and recording, or in any information storage or retrieval system, without permission in writing from the publisher and author.

Global trends and prospects of socio-economic development of Ukraine: Scientific monograph. Riga, Latvia: Baltija Publishing, 2022. 688 p.

ISBN: 978-9934-26-193-0

DOI: <https://doi.org/10.30525/978-9934-26-193-0>

The scientific monograph presents the global trends and prospects of socio-economic development of Ukraine. General questions of economics and enterprise management, regional economics, marketing, modern management, general pedagogy and history of pedagogy, theory and methods of vocational education, general questions of historical sciences, and so on are considered. The publication is intended for scientists, educators, graduate and undergraduate students, as well as a general audience.

Table of Contents

CHAPTER «ECONOMIC SCIENCES»

Yuliia Aleskerova, Volodimir Todosiichuk

FINANCIAL MONITORING STABILITIES
OF THE BANKING SYSTEM. 1

Valeriia Vovk, Anastasiia Krasnoselska

ECOLOGIZATION OF AGRICULTURAL PRODUCTION BASED
ON THE USE OF WASTE-FREE TECHNOLOGIES
TO ENSURE ENERGY AUTONOMY OF AIC. 59

Lyudmila Volontyr

THEORETICAL GROUNDS OF ASSESSING
THE PROBABILITY OF AN ENTERPRISE BANKRUPTCY
UNDER THE CONDITIONS OF THE PANDEMIC
AND ITS IMPACT ON EXPORT-IMPORT OPERATIONS IN UKRAINE. . . 88

Nadiia Hryshchuk

PECULIARITIES OF FINANCIAL INTERACTION
OF THE BANKING SECTOR OF ECONOMY REGARDING
FINANCIAL SUPPORT OF AGROFORMATIONS
IN THE CONDITIONS OF EUROPEAN INTEGRATION. 123

Svitlana Kovalchuk

AGRICULTURAL SECTOR IN THE CONTEXT
OF GREEN MODERNIZATION OF ECONOMY. 152

Olena Martseniuk

CURRENT STATE AND DIRECTIONS
OF INTEGRATION OF UKRAINE'S PENSION SYSTEM
INTO THE EUROPEAN AND WORLD PENSION SYSTEM. 177

Lyudmila Novitska

DIGITAL TECHNOLOGIES AS THE BASIS
FOR DEVELOPMENT TOURISM ACTIVITIES IN UKRAINE. 205

Oksana Ruda

INVESTMENT ATTRACTIVENESS OF THE ENTERPRISE:
CONTENT, FACTORS OF INFLUENCE
AND DIRECTIONS OF IMPROVEMENT. 228

Table of Contents

Dina Tokarchuk

THE CONCEPT OF ENERGY EFFICIENT AND ENVIRONMENTALLY SAFE COMPONENTS OF SUSTAINABLE DEVELOPMENT OF RURAL AREAS AND AGRICULTURAL ENTERPRISES 257

Oleksiy Tokarchuk

PROSPECTS FOR THE USE OF AGRICULTURAL WASTE FOR BIOGAS TO RELIABLY PROVIDE THE INDUSTRY WITH ENERGY RESOURCES 291

Inna Tomashuk, Ivan Tomashuk

EVALUATION OF EFFICIENCY OF USING RESOURCE POTENTIAL OF RURAL AREAS: METHODOLOGICAL APPROACH 319

Olena Tomchuk

ANALYTICAL INFORMATION IN THE MANAGEMENT OF AGRICULTURAL ENTERPRISES IN THE CONDITIONS OF EUROPEAN INTEGRATION. 349

Olha Khaietska

ORGANIZATIONAL AND ECONOMIC MECHANISM OF INCREASING THE COMPETITIVENESS OF AGRICULTURAL ENTERPRISES 379

Oleksandr Shevchuk, Svitlana Kiporenko

FINANCIAL SUSTAINABILITY OF AGRICULTURAL ENTERPRISES: DEVELOPMENT AND APPROVAL OF THE INTEGRATED EVALUATION MODEL 406

Oleksandr Shevchuk, Olena Shevchuk

THEORETICAL AND METHODOLOGICAL FUNDAMENTALS OF INTEGRAL ASSESSMENT OF FINANCIAL SUSTAINABILITY OF THE ENTERPRISE 440

CHAPTER «TECHNICAL SCIENCES»

Viktor Dzis, Olena Dyachynska

VISCOSITY AND THERMAL CONDUCTIVITY OF RUBIDIUM AND CESIUM IN THE GAS PHASE 468

Viktor Dubchak, Elvira Manzhos

APPLICATION EXAMPLES TO PROBLEMS OF MODERN MATHEMATICAL APPARATUS 539

CHAPTER «HISTORICAL SCIENCES»

Svitlana Bogatchuk

ACTIVITIES OF JEWISH SCHOOLS IN PODILLYA PROVINCE
IN THE SECOND HALF OF THE XIX CENTURY. 563

Yurii Boiko

THE RIGHT-BANK UKRAINE INDUSTRIAL PRODUCTION
AND INTRA-REGIONAL SPECIALIZATION
IN THE MID-19TH CENTURY. 585

Zorislav Makarov, Diana Bohatyrchuk

SCIENTIFIC RATIONALITY IN AN EDUCATIONAL CONTEXT:
HISTORICAL AND PHILOSOPHICAL ANALYSIS. 610

CHAPTER «PEDAGOGICAL SCIENCES»

Kostiantin Levchuk

EDUCATION IN THE UKRAINIAN FOREST-STEPPE PROVINCES
OF THE RUSSIAN EMPIRE IN THE FIRST HALF OF THE XIX CENTURY 629

Elena Levchuk, Natalia Havryliuk

PEDAGOGICAL CONDITIONS OF PROFESSIONAL TRAINING
INTEGRATION OF SPECIALISTS IN AGRARIAN SPHERE. 653

CHAPTER «ECONOMIC SCIENCES»

FINANCIAL MONITORING STABILITIES OF THE BANKING SYSTEM

Yuliia Aleskerova¹

Volodimir Todosiichuk²

DOI: <https://doi.org/10.30525/978-9934-26-193-0-1>

Abstract. *The purpose of the article* is to substantiate the theoretical approaches to determining the place and role of the banking system in the economic development of the state, improving the methods of its measurement and regulation. The research data were carried out on the analysis of “Oschadbank”. The financial security of the bank is the most important component of the financial and, therefore, national security of the country, it is a state of a commercial bank, which is characterized by resistance to threats of different nature and balance, the ability to achieve the planned strategic goal and generate sufficient financial resources to ensure compliance. Characterizing the financial security of commercial banks, it is necessary to focus on key parameters: financial security ensures a balanced and stable financial condition of the bank; contributes to the efficient operation of the bank; well-organized financial security allows to identify problem areas in the bank’s activities in the early stages, as well as to neutralize the impact of crises to prevent bankruptcy. *Results.* Banking regulation is the process of promoting financial stability through the use of special methods, tools, by establishing specific rules and regulations. Therefore, the functions of banking regulation are closely related to the conduct of monetary policy and the organization of the settlement system and

¹ Doctor of Economics, Professor,
Vinnytsia National Agrarian University, Ukraine
ORCID: <https://orcid.org/0000-0003-3072-4854>
ResearcherID: M-6099-2018

² Ph.D., Associate Professor,
Vinnytsia National Agrarian University, Ukraine
ORCID: <https://orcid.org/0000-0002-3498-1295>
ResearcherID: L-8200-2018

have historically been carried out by central banks. Supranational banking regulation is a regulatory process carried out by world-class international organizations (IMF, IBRD, EBRD, BCBS). Banking supervision is the control over the stability and stability of the banking system, which must adequately respond to global trends and reassess supervisory policy. From the standpoint of methodology, banking supervision should be understood as a set of methods, techniques, tools used by banking supervisors to monitor the performance of banks, the application of measures of influence and so on. Banking supervision is based on a constant analytical survey of banks and serves socio-economic needs, as there is a close relationship between risk analysis and banking supervision. In Western and domestic scientific sources, the issue of banking supervision is often identified with the analysis of the causes of banking risks and methods of their study. An analysis of the literature has shown that the study of risks has a long history, but the active study of financial risks began relatively recently – in the late nineteenth – early twentieth century. *Value/originality*. The scientific novelty of the work is determined by the following provisions: improved comprehensive approach to monitoring the activities of banks, which allows to obtain a quantitative description of their impact on the banking system of Ukraine.

1. Introduction

Banking is an ancient science. It accumulates thousands of years of experience in credit institutions, reveals what has long been formed as mandatory principles of banking. Monetary, credit relations as elements of economic relations reflect the most complex phenomena of life, as they relate to relations between people as its most complex subjects. Money, credit give society a significant incentive for development, gives a whole system of special relationships, special order and a high degree of organization.

The bank as a specific enterprise produces a product that is significantly different from the product of material production, it produces not just goods, but goods of a special kind in the form of money, means of payment. Money is a reproducible category; Cash money issued by the bank as the sole monopolist in the total mass of the subjects of reproduction, serves both the sphere of production and distribution, exchange and consumption. In addition to this product, banks also provide a variety of services, mostly

financial. In short, banks are “suppliers of money” to society, ie we can say that the bank plays an important role for people. Each bank has its own little secrets of success – a wide and extensive branch network, establishing and developing relations with Belarusian and foreign banks on the basis of mutually beneficial and long-term cooperation, improving service technologies and introducing new services. We can assume that the more services, the higher the rating, therefore, public confidence in banks will be higher, and the greater the role of the bank in people’s lives. The key to the bank’s success in the services it provides to individuals and legal entities.

The banking sector is undergoing constant change and development. This is with the development of the country’s economy, foreign economic relations, world financial markets, as well as state regulation of banking. Methods of work of banks, forms of customer service, technologies of performance of operations change. The informatization of banking should play a leading role in solving these problems. Remote customer service comes to the fore when all possible access channels are used. Rapid development of mobile devices and increased mobility of customers themselves make remote service operations more popular. Internet services (Internet banking) of banks are already in place and will be developed, as the speed of service provision is important. This allows you to manage your accounts online from anywhere. Customer relationship management in banking with a focus on the client as a leading direction in banking ensures the stability and competitiveness of the bank.

The urgency of issues related to the place and role of the banking system in the economic development of the state, the need for deeper development of relevant theoretical and methodological and information-analytical support led to the choice of work topic, its purpose and objectives.

The aim of the work is to study the state and development of the banking system of Ukraine and develop recommendations of economic, regulatory, informational and organizational nature to regulate the activities of foreign banks taking into account national economic interests and the challenges of globalization.

Achieving the goal of work was based on the use of general scientific methods of cognition (analytical, synthetic, dialectical, historical) – in the study of the nature, causes and consequences of banks and strategies for their regulation; methodological principles of a systematic approach – in the

study of the functional and organizational structure of the regulatory system of foreign banks and the development of proposals for its improvement, as well as special techniques and methods of analytical research. The research methodology is based on observation, measurement and characterization of objective economic phenomena, followed by analysis of results using mathematical and statistical methods, methods of structural analysis and forecasting, development and practical implementation of existing methods, theoretical generalization of identified trends and patterns.

The study was conducted on the basis of laws and regulations of the Verkhovna Rada of Ukraine, the Cabinet of Ministers of Ukraine, the EU, official statistics of the National Bank of Ukraine, the Ministry of Finance of Ukraine, the Association of Ukrainian Banks, the State Mortgage Institution, the Deposit Guarantee Fund, Ukraine, information-analytical and rating agencies. The study used the reporting data of commercial banks of Ukraine and consolidated financial statements of transnational banks, monographs, publications of domestic and foreign scholars on the study of foreign banks.

The scientific novelty of the obtained results is the substantiation of theoretical approaches to determining the place and role of the banking system in the economic development of the state, improving the methods of its measurement and regulation. The scientific novelty of the work is determined by the following provisions: an integrated approach to monitoring the activities of banks has been improved, which allows obtaining a quantitative description of their impact on the banking system of Ukraine.

2. Theoretical principles of determining the nature and assessment of financial stability of the banking system

Ukraine is one of the countries whose financial industry is developing within the bank-centric model. In the total assets of the financial sector, the share of banks exceeds 80%, which determines their important role in the formation and distribution of cash flows of the economy. One of the main sources that generates these flows is lending, which, including interbank lending, accounts for 69.2% of the total assets of the country's banking system.

Banks are the center of the financial system, the stability of which is the most important condition for economic development. For Ukraine to

achieve and maintain the modern world level. The organization of banking is of paramount importance. The process of market transformation began with the reform of the banking system and so far serious positive results have been achieved in this direction. Banks are trust companies inherent in any functioning economy. Formations engaged in lending and financing of industry and trade, retail business at the expense of money capital attracted in the form of deposits and by issuing own shares and equity and debt securities. They provide cash services to customers, as well as perform cash transactions at the bank's cash desks and its remote units. The special role of the banking system is to ensure stable economic growth, expand the capacity of enterprises to attract financial resources, in maintaining and increasing the savings of citizens. Without a strong banking system there can be no strong economic system of the country.

Banks in Ukraine are the main providers of financial services. As of April 1, 2019, the total volume of loans granted by banks to non-financial corporations and individuals reached 48.9 trillion UAH (52% of all assets of the banking system). Banks' investments in debt make up 11.2% of all assets. Banks are the largest operators in the domestic foreign exchange market (over 90%), the repo market (about 85%) and the bond market (almost 70%). Ukrainian banks perform an important social mission to ensure the availability of financial services for citizens and organizations of all forms of ownership, regardless of population density and geographical distances. Remote banking has become widespread: 93% of accounts of individuals and 98% of accounts of legal entities provide access via the Internet. The banking system belongs to the sectors of the economy that are characterized by a high degree of vulnerability to the negative effects of external shocks and fading macroeconomic dynamics. The high sensitivity of banking to crisis scenarios is explained, though not entirely, by its dependence on the behavioral psychology of customers, which, especially in the face of signs of financial instability, and even more panic, may acquire features of irrationality. The number of banks in Ukraine reached its peak by the mid-1990s, when their number exceeded 2,500. Excluding local crises (1995 and 2004), there were three waves of decline. All of them were related to the implementation of crisis scenarios of economic development: default in August 1998, the global financial crisis of 2008–2009 and the currency crisis in 2014–2015.

Thus, the concept of “financial stability” originates in the practical problems associated with the emergence and overcoming of financial crises, which governments and central banks of almost all countries have faced in different historical periods. This concept began to develop most actively in the 90s of the twentieth century. At this time, the liberalization of capital movements, the rapid development of the financial services market for foreign capital and other economic globalization processes observed in many countries have clearly demonstrated the danger of financial imbalances and the possibility of rapid financial crises. Against this background, the urgency of the problem of ensuring financial stability in general, the stability of financial relations of all sectors of the economy, as well as reducing the likelihood of systemic financial destabilization.

Table 1 shows the views of foreign practitioners to determine the essence of financial stability.

Summarizing the existing definitions of the concept of “financial stability” in the scientific literature (Table 1), we should distinguish three approaches to its interpretation: direct (functional), inverse and mixed definition.

1. Direct definitions contain a description of the functions and other characteristics that a stable financial system should have. These definitions are based on the thesis that the financial system is stable as long as it performs its functions. This approach was presented by practicing economists at the Deutsche Bundesbank and the Bank of Poland.

Table 1

**The essence of the concept of “financial stability”
in terms of foreign scholars and practitioners**

Author	Definition of “financial stability”
A. Krocket, Head of the Financial Forum stability	this is the lack of instability, a situation in which economic activity is negatively affected by fluctuations in the prices of financial assets or there is an inability of financial institutions to meet their obligations
Maykl Fut (UK Financial Services Authority)	is determined by: a) monetary stability; b) the level of employment close to the normal rate of employment in the economy; c) trust of economic entities in financial institutions and markets; d) the absence of relative fluctuations in prices for real or financial assets.

Chapter «Economic sciences»

(End of Table 1)

Author	Definition of “financial stability”
Vim Duyzenberh (Head of the European Central Bank)	means the smooth functioning of the key elements that shape the financial system.
Rodzher Ferhyuson Jr., Member of the Board of Governors of the US Federal Reserve	should be defined by its opposite – financial instability, which is determined by three criteria: (1) prices for key financial assets that deviate significantly from fundamental values and (or) (2) failures in the functioning of securities markets and access to credit within the country and, possibly at the international level; (3) aggregate costs that deviate significantly from the potential value.
Deutsche Bundesbank	describes a stable state in which the financial system effectively performs its key functions, in particular, resource allocation and risk reduction, as well as payments.
Bank of Norway	is determined by the absence of crises in the financial system, ie the resilience of the financial sector to shocks arising from the activities of financial institutions or the functioning of financial markets.
Bank of Poland	a situation where the system continuously and efficiently performs all its functions, even in conditions of significant unexpected and negative shocks.
Bank of the Czech Republic	a situation where the financial system operates without significant defects or undesirable effects on the current and future development of the economy as a whole, which indicates a high degree of resilience of the system to shocks.
Nout Vellink , President Bank of the Netherlands	a stable financial system is able to efficiently allocate resources and absorb shocks, prevent the impact of their devastating effects on the real economy and other financial systems.
Harri Dzh. Shynazi	The financial system can be considered stable if it: 1) facilitates the efficient allocation of economic resources in space and time, as well as other financial and economic processes; 2) allows you to assess and allocate financial risks, as well as manage them; 3) retains the ability to perform these important functions even in external externalities or when increasing economic imbalances.

2. Direct definitions contain a description of the functions and other characteristics that a stable financial system should have. These definitions are based on the thesis that the financial system is stable as long as it performs its functions. This approach was presented by practicing economists at the Deutsche Bundesbank and the Bank of Poland.

3. In the opposite definitions, financial stability is interpreted as the absence of financial instability, ie the absence of financial crisis. Representatives of this approach are John Chant (Bank of Canada Advisor), Roger Ferguson Jr. (Member of the Board of Governors of the US Federal Reserve) and H.F. Minsk. However, this approach to the interpretation of the concept of “financial stability” has drawbacks. First, the financial crisis is a complex, complex and multifaceted concept that needs a clear scientific definition. Secondly, the definition of financial stability due to the lack of financial instability does not give any recommendations to government regulators on what specific actions should be taken in a stable situation in order to maintain it.

4. The mixed approach is the simultaneous application of direct and inverse definitions of the concept of “financial stability”. A mixed approach includes alternative formulations of financial stability, such as the definition given by M. Foote or Harry J. Shinazi.

Based on the analysis of the above definitions and agreeing with the author, the following characteristics are revealed, which reveal the meaning of “financial stability”: systemic (it arises as a synergistic result of interaction of financial institutions, financial markets and infrastructure, and financial relations economy); the plurality of possible states (financial stability is not the only fixed state, but the range of possible values, each of which is characterized by a certain “margin of safety” of the financial system); relative (because there is always a theoretical probability of financial destabilization, even in the most stable financial systems); dynamic aspect (in the presence of financial stability in the current period t_1 existing risks are identified and assessed properly. Proper assessment of risks that may manifest themselves in the future allows to ensure financial stability in periods t_2 and t_3 , etc., if not occur unexpected and/or significant negative macroeconomic or financial shocks); based on trust in the financial system (without trust in financial institutions, markets, instruments, financial infrastructure there can be no financial stability); ability to fully absorb negative shocks within the financial system (lack of negative impact on the real economy by the financial system in a state of financial stability).

Taking into account the object of dissertation research, the author clarified the concept of “financial stability of the banking system”, differences in the interpretation of the relevant category for the level of an individual bank.

Research and generalization of scholars' interpretations of the concept of "financial stability of the banking system" allowed to identify the following theoretical approaches to determining its economic essence.

The second theoretical approach, formed by O.I. Baranovskiy and S.K. Reverchuk, who saw the stability of the banking system as its ability to withstand external and internal influences, while maintaining the ability of the system to perform its functions and operations, provided its integrity and stability of elements, which allows the system to return to equilibrium after external and internal forces. This interpretation of the stability of the banking system is based on the need to preserve the properties inherent in any system – integrity, organization, functionality, which depends on the stability (stability) of the system, ie the ability to function properly, maintain its structure and functions. A similar definition of the studied concept is given in which the stability of the banking system is a complex characteristic of the banking system, which implements its essence and purpose in the economic system, adequately and effectively performs its functions, and provides the ability to maintain balance and restore after external shocks or increasing disparities, any deviations from the safe parameters caused by the crisis.

The third theoretical approach to determining the economic meaning of the concept of "financial stability of the banking system" is to focus on the need to ensure financial stability and stability of the elements of the banking system, which are banking institutions. Thus, N.P. Pohorelenko emphasizes that to achieve such a qualitative characteristic as the stability of the banking system, which determines the stability of the economic environment that surrounds the bank, is impossible without ensuring the stability of individual banks.

The fourth approach is to interpret financial stability through the connection of the banking system with the financial and macroeconomic systems. Yes, O.O. Zatvarka notes that the stability of the banking system means the balance of its components, the presence of interconnected and mutually agreed proportions between them in both sectoral and regional aspects, as well as maintaining balance and effective relationship with the financial and macroeconomic systems.

In the fifth theoretical approach, the content of the stability of the banking system is determined in terms of stability of operation,

development and preservation of its structure. Yes, L.A. Bondarenko and M.V. Tarasenko consider the stability of the banking system as the stability of functioning, ie the ability of the banking system to fulfill its obligations to its counterparties; as the stability of development, ie the stability of the positive dynamics of the characteristics of the banking system; as the stability of the structure, ie the commitment of the elements of the banking system (banks) of a particular model of functioning and the invariability of this commitment over time. The need to take into account the time factor also indicates L.A. Zveruk, emphasizing that the financial stability of the banking sector is a concept that defines the development of the banking sector in the long run, it should be understood as the absence of obstacles to the dynamic development of the banking sector to effectively play the role of financial intermediary in the economy.

Having analyzed the interpretations of the financial stability of the bank, it should be noted that the concept of “financial stability of the bank” has common key characteristics with the concepts of “financial stability” and “financial stability of the banking system”. Therefore, when disclosing the content of the bank’s financial stability, it is advisable to take into account such key features as: systemic nature (financial stability arises as a result of financial relations arising both inside and outside the bank) and dynamic (the need to take into account time).

Thus, the financial stability of the bank should be understood as a characteristic of its condition, when the bank has the ability to withstand imbalances in the financial environment and ensure the smooth operation and development in the strategic perspective.

The question of the relationship between the concepts of “financial stability” and “financial stability” is also debatable.

The analysis of scientific opinions on the relationship between the concepts of “financial stability” and “financial stability” allows us to conclude that the first category characterizes changes in the basic parameters of the banking system in a longer period than financial stability. This raises the question of how to interpret the results of the assessment of financial stability in the short term. Approaches to assessing the financial stability of the banking system and their compliance with certain criteria (taking into account the identification features of the system and the aggregation of analytical data) are presented in table 2.

**Analysis of existing approaches
to assessing financial stability banking system**

Author / authors of the approach	Indicators proposed to be used to assess the financial stability of the banking system	Conformity approach criteria	
		K1	K2
I.I. Dyakonova, Ye.Yu. Mordan'	indicators of financial stability (solvency, profitability, liquidity, credit and currency risks), financial vulnerability (reflect macroeconomic conditions, including the state budget, foreign exchange reserves and the real sector), economic climate (characterize the state of the main counterparties of Ukraine).	+/-	+
K.M. Zhulins'ka	indicators of economic efficiency, capital adequacy, liquidity and risk.	+/-	+
V.I. Mishchenko, O.K. Malyutin	indicators of capital adequacy, asset quality, liquidity, efficiency, sensitivity to interest rate and currency risks.	+/-	+
I.M. Chmutova, V.Yu. Bilyayeva	indicators of capital adequacy, liquidity, business activity and efficiency.	+/-	+
V.V. Kovalenko and Yu.O. Harkusha	indicators of capital adequacy, liquidity, business activity, efficiency and concentration in the banking services market	+/-	-
T.V. Protsyk	indicators of bank capitalization, accounting policy, bank liquidity and rates of change.	+/-	+
V.V. Kovalenko	indicators characterizing the external environment of the banking system (indicators estimating GDP; indicators characterizing the inflation process; trade balance indicators; indicators characterizing the place of banks in the macro environment; monetization indicators; indicators characterizing the level and conditions of bank refinancing; indicators characterizing the effectiveness of monetary policy) and indicators characterizing its internal state (indicators of scale; indicators of saturation of banking services; indicators of stability and liquidity; indicators of profitability; structural indicators of assets and liabilities).	+/-	-
K1 and K2 – criteria for taking into account the identification features of the system and the aggregation of analytical data within the approaches to assessing the financial stability of the banking system.			

Despite the fact that M.I. Zvyeryakovym, L.V. Kuznyetsovoyu and V.V. Kovalenko assessment in his scientific publications identified the financial stability of the banking system (rather than financial stability), presented in approaches based on sound conclusions about the relationship of relevant concepts is quite legitimate to consider in this study. Comparing the proposals of scientists on the content of evaluation indicators allows us to draw the following conclusions about their common features and fundamentally important differences (in terms of systems analysis).

The analysis of the considered approaches to the assessment of the financial stability of the banking system allows us to conclude that none of them fully takes into account the presence of complex relationships between its elements, features of internal organization, place in the economy, main functions. These aspects allow us to single out the general systemic features of the banking system, which, along with integrity, hierarchy and purposefulness, includes its emergence, which in the context of assessing and monitoring the financial stability of the banking system has significant practical value.

A large number of scientific works have been devoted to the peculiarities of the emergence of emergencies and the application of the emergent approach to the study of various economic systems. At the same time, in the banking sector, aspects of the impossibility of reducing the properties of the system to the sum of the properties of its elements are poorly studied and are considered in a small number of publications.

The assessment of financial stability of the banking system is proposed in the following areas: intensity of credit and financial interaction in the interbank market. function to neutralize the lack of financial resources in other interbank market participants); functional load of the banking system in ensuring macroeconomic development, structural changes and financial imbalances in the banking system and economies of scale resulting from changes in the main financial parameters of systemic banks.

In summary, we can conclude that the proposed approach to assessing the financial stability of the banking system taking into account such a property as emergence is complex and takes into account all major factors that characterize the banking system as a complex system. In the context of the indicative space of features used for assessment based on the emergent properties of the banking system, the author's proposal is to take into

account the diversity of financial processes that may occur simultaneously in the system (profitable and unprofitable banks, excess and lack of liquidity sufficient level of capitalization created with the participation of both public and private capital, including foreign capital, etc.) and the level of financial stability of systemic banks, the reduction of which leads to destabilizing impulses and crisis trends in the banking sector.

3. Economic crisis effects on consumer behavior

Ensuring the financial stability of the banking system of Ukraine is one of the priority goals of the National Bank of Ukraine as the Regulator of the banking sector in the country. According to the Constitution of Ukraine, the Laws of Ukraine “On the National Bank of Ukraine” and “On Banks and Banking”, the National Bank of Ukraine regulates and supervises banking and determines the features of regulation and supervision of systemically important bank (hereinafter CBB), a bank with settlement center status. on servicing contracts in financial markets, taking into account the specifics of such banks.

The problem of implementation of banking regulation from the standpoint of its target orientation, functional manifestation of the Regulator and content load is widely studied by leading Ukrainian and foreign scholars. Despite the thorough work of scientists on these aspects, further research is needed on the content of the concept of “banking regulation”, given the importance of its impact on ensuring the financial stability of the banking system.

Sydorenko O.M. identifies four main approaches to the definition of “banking regulation”: 1) regulatory (banking regulation is seen as a process of streamlining and standardizing the requirements, rules and standards to be followed by banks in the organization of operations, operations, relations within the banking system); 2) regulatory control (within this approach, regulatory banking regulation is supplemented by a set of control procedures); 3) anti-crisis (regulation is aimed at all operations and processes, the conduct of which may primarily affect the stability of the banking system, and gradually the state of the national economy); 4) strategic (banking regulation is considered from the standpoint of determining the priority goal – ensuring the stability of the banking system). According to current legislation, banking regulation is interpreted as one of

the functions of the National Bank of Ukraine, which is to create a system of rules governing the activities of banks, determine the general principles of banking, banking supervision, liability for violations of banking legislation. Representatives of European schools and some Ukrainian scholars consider the concept of “banking regulation” through the prism of micro- and macroprudential supervision, which is based on the ability to monitor and mitigate credit risks that depend on the stability of the banking system at the macro and micro levels. According to current legislation, banking regulation is interpreted as one of the functions of the National Bank of Ukraine, which is to create a system of rules governing the activities of banks, determine the general principles of banking, banking supervision, liability for violations of banking legislation. Representatives of European schools and some Ukrainian scholars consider the concept of “banking regulation” through the prism of micro- and macroprudential supervision, which is based on the ability to monitor and mitigate credit risks that depend on the stability of the banking system at the macro and micro levels. To eliminate the vagueness of delimitation and identify the essential features of the morphological analysis of the category of “banking regulation”, which allows you to find a significant number of all possible ways to define the concept by combining basic structural elements or features, which allows you to choose the most complete. Researchers studying financial security point out that the problem has two aspects. On the one hand, it is necessary to work on ensuring the financial security of the banking system as a whole, and on the other hand, it is also necessary to study the issues of ensuring the financial security of a particular banking institution. Bank security is part of the country’s financial security as a special part. The banking system is the most important component of the financial and credit sphere of any state. And that is why the level of financial security of the state determines the state of the banking sector. Financial intermediaries are the catalysts of globalization through the latest modern information technology. The integration of Ukraine’s banking system into the global financial space poses threats to the financial stability of banks, which are exacerbated by the economic crisis but, at the same time, opens up new opportunities for the development of the domestic financial sector.

The issue of tools for financial security of commercial banks is insufficiently covered by modern economics. To date, we can say that there

is no single list of external, internal methods and tools of financial security of a commercial bank. The existing works concern only certain aspects of the financial security of a commercial bank. Studies of the financial stability of banking institutions are conducted, various aspects of improving financial management are analyzed, a large number of scientific papers are devoted to the study of liquidity and banking risks, but all these are separate parts of the picture. At the same time, there is a lack of research that allows to form a holistic vision of the tools for ensuring the financial security of a commercial bank. Financial security as an economic category includes the concept of financial stability. In general, it should be noted that the financial stability of a commercial bank is an important condition for ensuring its financial security. Well-known foreign scholars paid a lot of attention to the issue of financial stability of commercial banks E.Dzh. Dolan, R.L. Miller, P.S. Rouz, Dzh.F. Synk (mol.), Dzh. K. Van Khorn and others. It should be noted that in the works of foreign scholars the concept of “financial stability” is used identical to the concept of “financial stability” as a characteristic of the equilibrium state of the economic system, which is dynamic, provides constant growth and is a necessary condition for improving the situation firm levels.

Ukrainian scientists began to study the financial stability of commercial banks only with the beginning of reforms aimed at establishing the foundations of Ukraine’s market economy as an independent state. Some aspects of financial stability have been considered by such prominent scholars as: A.N. Moroz, M.I. Savluk, O.D. Zaruba, M.F. Pukhovkina – in the study of financial management and analysis of banks; K.Ye. Rayevs’kym, R.I. Shyllerom, V.P. Pantelyeyevym, S.P. Khalyavoyu – when substantiating approaches to ensure profitability, liquidity, solvency of commercial banks, analysis of the results of their activities, financial reporting, summary assessment of the financial condition of a commercial bank; A. Mazaraki, N. Shul’hoju, L. Svystun – in substantiation of methodological bases of construction of rating systems of estimation of activity of commercial banks; N.M. Shelud’ko – in identifying factors and criteria for financial stability of commercial banks.

Characterizing the above definition of financial stability of banks in terms of achieving the main purpose of the business entity (including the bank), we can say that it is incomplete because it has no requirements

for profitable activities of the entity (bank) and its quality assets, which in our opinion should be one of the necessary conditions for the financial stability of a commercial bank and ensure a high level of financial security of the banking institution. N.H. Antonov and M.A. Pessel' argues that financial stability is liquidity and solvency. In our opinion, the definition of N.H. Antonova and M.A. Pessel' is also incomplete, as taking into account only the liquidity and solvency of the bank in determining this category is not enough.

Yudanov A.YU. considers that a sign of financial stability is stability as the ability to be in a privileged, relatively less vulnerable position during crises and the ability to overcome them. Thus, stability is only a qualitative characteristic of stability, the latter has a dynamic nature and is based not only on stability but also on the laws of equilibrium. I.V. Larionova considers stability as a concept based on stability, ie the ability to withstand internal and external influences, maintain a stable balance and reliability for a long period of time. Thus, we can conclude that the etymology of the term "stability" is based on the constancy of the state, keeping within the required limits of certain parameters. In a broader sense, this term means the ability of a system to perform its functions against the action of endogenous and exogenous factors. Well-known researcher of economic security problems O.I. Baranovs'kyy provides the following interpretation of the concept of "financial security of the bank" – it is: 1) a set of conditions under which potentially dangerous to the financial condition of the banking institution actions or circumstances are eliminated or reduced to a level at which they can not cause damage to the bank, preservation and reproduction of its property, infrastructure and prevent the bank from achieving statutory goals; 2) the state of protection of financial interests of a commercial bank, its financial stability, as well as the environment in which it operates.

The contribution of these scholars to solving the problems of financial security at different levels and in different areas is invaluable, but it should be noted that the issues of financial security of banks are still insufficiently studied. For example, taking into account a number of specific risks in the activities of banks, using the leading experience of domestic and foreign banks, diagnosing and assessing the level of financial security of the bank, as well as the use of financial management tools. That is why the current research topic was chosen.

The financial security of the bank is the most important component of the financial and, therefore, national security of the country, it is a state of a commercial bank, which is characterized by resistance to threats of different nature and balance, the ability to achieve the planned strategic goal and generate sufficient financial resources to ensure compliance. Characterizing the financial security of commercial banks, it is necessary to focus on key parameters: financial security ensures a balanced and stable financial condition of the bank; contributes to the efficient operation of the bank; well-organized financial security allows to identify problem areas in the bank's activities in the early stages, as well as to neutralize the impact of crises to prevent bankruptcy. To determine the financial stability of a commercial bank, first of all, it is necessary to emphasize the distinction between the methods of normal and crisis management, as the management of a stable commercial bank and a bank experiencing financial difficulties, of course, is different. This does not mean that the list of instruments is changing, but such a distinction allows you to use the experience in the field of financial management, as well as the financial stability of the banking institution. An analysis of existing publications shows that all the methods and tools used to ensure the financial security of a commercial bank can be divided into two separate large groups: internal and external. This section is based on two preconditions. On the one hand, the bank, like any business entity, has economic independence and, accordingly, it can take certain steps to achieve financial security. On the other hand, its activities are influenced by the state, which has its own tools to influence the activities of banking institutions.

It is necessary to consider the internal tools available to commercial banks and methods of ensuring financial security. To do this, use the study of financial management. It has a number of features due to the nature of banking. Unlike enterprises that produce and sell goods, provide services, banks are financial institutions, whose main activity is to work in financial markets. That is, financial transactions are the main activity of banks. Based on this, the financial management of a commercial bank is, on the one hand, the management of its operations, and on the other – is part of an interdependent process, which distinguishes liquidity management, financial risk management, profitability management and effective performance. Financial management, as a system of economic management, is a set of

organizational, structural and functional subsystems. Commercial banks are objects of management that include all aspects of its financial activities, including capital, liquidity and solvency, borrowed and borrowed resources, assets, financial instruments, banking products and services, financial results and taxes. The subject of management will be the responsible person or group of persons who have the right to make decisions, are responsible for the effectiveness of the management process of a commercial bank.

The financial management process includes subsystems of regulatory support, which is divided into external (laws, regulations, resolutions, orders, etc.) and internal (instructions, guidelines, standards developed by the bank to regulate its financial activities); information support (economic, commercial, financial and other reporting); technological support; staffing. The tools of bank management are the functions of financial management. In the textbook “Financial Management”, edited by Doctor of Economics, Prof. Momot T.V., the main functions of management are defined, such as: research of the external environment; development of financial strategy; analysis and planning of financial activities; decision-making on operational financial activities; making investment decisions; interaction with other counterparties on financial activities. Given the functions of financial management in a banking institution, we can identify the following interdependent areas: 1) financial planning; 2) financial analysis; 3) financial regulation; 4) financial control.

The functional model of financial management in the bank can be presented in the form of a diagram presented in Figure 1. This scheme is standard and is given in most textbooks on financial management. This division is quite logical and is based on a common list of forms of financial management. The planning process is a systematic setting of goals and determining the composition of the structure and sequence of activities aimed at achieving them. This process allows you to identify tasks that ensure the effective functioning of the bank in the long run and rapid adaptation to changing environmental conditions. The main trends in the formation and use of financial resources of the bank are determined, financial relations with counterparties are formed.

The main objects of financial planning in banks are assets and liabilities, the portfolio of banking services and related income and expenses. The financial plan consists of two parts: the plan of the banking portfolio, on

the one hand, the budget – on the other, as well as the reflected production and portfolio functions of the bank. A financial plan is a document in which the bank's budget and the plan of its banking portfolio are logically connected elements of a single system. The formation of the budget of a commercial bank is carried out in relation to the system of its objects, ie budget units and is to determine the specific technology of financial management. Thus, planning is a continuous and comprehensive process and includes the following stages: 1) development of the bank's financial model; 2) calculation of forecast financial results, formation of forecast balance of resources and investments, preparation of capital movement plan, banking operations plan, plan of development and implementation of new banking products and services, calculation of forecast indicators and standards; 3) setting limits on the cost of maintaining the bank, determining the minimum margin, calculation of tax payments and mandatory deductions.

Financial analysis is one of the main functions of financial management. Financial analysis is a process of studying the financial condition and main results of the bank's financial activities in order to identify reserves to increase its market value and ensure effective development. Its importance is explained by the fact that the analysis data are used as a basis for other financial management tools of the bank. The main tasks of financial analysis are: determination of indicators and standards of the bank's activity established by external regulatory bodies; definition and analysis of indicators that characterize the process of managing the assets and liabilities of the bank as a whole and managing certain types of its active operations, taking into account the liquidity of the funds invested in them; definition and analysis of indicators that characterize the process of managing commissions and trading operations of the bank; determination of internal indicators and standards governing the degree of risk (including liquidity risk) of banking operations; determination and analysis of indicators of profitability of the bank and the efficiency of the capital management process (own funds) of the bank; definition and analysis of performance indicators of individual divisions of the bank and certain types of operations, analysis of factors influencing performance indicators.

The next tool is regulation. This is an objective process based on the definition of boundaries, which is carried out using various methods and appropriate tools to achieve a specific goal, which involves influencing the

object of management to eliminate deviations from the specified parameters (schedules, plans, norms and standards). The specifics of banking requires the allocation of the following functions in the financial regulation: operational management of bank profitability; operational management of the bank's financial risks; operational cash management in order to maintain the required level of liquidity.

Professor Savchenko L. gives the following definition: financial control is the activity of state bodies and non-governmental organizations endowed with the appropriate powers, aimed at ensuring legality, financial discipline, rationality in the mobilization, distribution and use of state financial resources.

The control system, which ensures the concentration of control actions on the highest priority areas of the bank, timely detection of deviations of actual results from the budgets and making operational management decisions to ensure the stability of the banking institution – is financial control. Its action is to verify the compliance of the results of the banking institution, control over compliance with liquidity standards, limits and indicators set by the NBU, taking into account various financial risks; control over the implementation of planned tasks that reflect the required volume and efficiency of the bank's operations. The information base of financial management is the internal information of accounting, internal banking, legal and regulatory framework of legislative and regulatory bodies, external economic information. External instruments for ensuring the financial security of banks are one of the important groups, which include: banking regulation; banking supervision; banking control. According to the Law of Ukraine "On the National Bank of Ukraine" banking regulation is one of the functions of the National Bank, which is to create a system of rules governing banks, determine the general principles of banking, banking supervision, liability for violations of banking legislation.

One of the most important external methods of ensuring the required level of financial security of banks is the implementation of banking supervision. According to the Law of Ukraine "On the National Bank of Ukraine" banking supervision is a system of control and active actions of the National Bank aimed at ensuring compliance with banks and other financial institutions in their activities the legislation of Ukraine and established standards to ensure stability of the banking system and protection interests of depositors. The

last group of external instruments to ensure the financial security of banks according to the basic classification is banking supervision. Most economic dictionaries define external banking control as central bank control over the activities of commercial banks. That is, it is a system of economic relations aimed at ensuring the reliability, efficiency, legality, security of banking and improving the efficiency of the existing system of financial security of banking institutions. The specifics of control over banks and banking activities by the state due to a number of features inherent in the banking sector, as well as its role in national security. First, the banking system mediates the passage of payments of almost all economic entities of the country, secondly, the banking system is characterized by a high level of systemic risk, which applies not only to the banking system but also to the entire economy, and thirdly, monetary flows through banking channels are closely monitored by financial and law enforcement agencies. The main criterion for the efficiency and quality of the bank's security is the stability of its financial and economic development in accordance with plans and objectives, regardless of changes in the situation. PJSC CB Oschadbank has an internal audit service, which is an independent structural unit of the bank, which is the body of operational control of the Supervisory Board. It is created by the decision of the highest body of the Bank in order to verify and assess the adequacy and effectiveness of the internal control system and the quality of performance of assigned duties by employees of the Bank. The analysis of financial and economic security of the bank is an analytical center of risk management, which aims to combine the efforts of departments involved in research, prevention, risk analysis by forming tasks for assessment, control, confirmation of assumptions made on the basis of analysis of operations in the form of mathematical series, further initiation of inspections and back-testing of assumptions and forecasts, development of management decisions to improve operational security and minimize risks based on the data obtained during inspections. Given all the above, we can formulate the following definition of the financial security of the bank: a set of interrelated diagnostic, instrumental and control measures of a financial nature, which should optimize the use of financial resources, ensure their proper level and mitigate internal and external risks. It is advisable to recommend commercial banks to use the experience of the leading Ukrainian bank PJSC CB Oschadbank in the

field of sustainability through an effective financial security system. Thus, the assessment of the current level of theoretical basis needed to build a financial security system of the bank, showed that there is not only a fundamental possibility of this, but also accumulated a sufficient amount of theoretical and practical knowledge in this area. The main problems are the lack of clear systematization of knowledge, as well as their adaptation to the conditions of the modern Ukrainian economy. Therefore, the construction of an effective system of financial security of banks is a necessary condition for the stability of the individual bank and the banking system as a whole. Given the key role of security of the banking system in the security of the country, these tasks can be made a priority for national security. At this stage of development of the banking system of Ukraine, the tools to ensure its financial stability are presented as follows in table 3.

According to table 3, the main current and potential for implementation tools of banking regulation in the system of organizational and economic support of financial stability of the banking system, the variability of which is due to the objects of regulation and problems in the process of achieving financial stability.

Representatives of the Central Bank of Sri Lanka identify financial (banking) institutions and their operations as the main objects of regulation in the process of financial stability research. According to the instruments of macroprudential (and sometimes microprudential) regulation, as a direction of banking regulation used in the context of achieving financial stability, and recommended by the Global Stability Committee, the objects of organizational and economic support of financial stability of the banking system are the bank and credit requirements), and the Group of Thirty – leverage, liquidity, credit expansion, Basil I, II, III – capital, liquidity, risks, information, market discipline. In addition, according to the official position of the National Bank of Ukraine, according to the vector orientation of the application of mandatory economic standards, the objects of regulation are capital, liquidity, credit risk, asset quality and investment. Thus, in addition to the above objects of regulation in the context of achieving financial stability of the banking system, according to previously concluded conclusions on the assessment of financial stability of the banking system taking into account the properties of emergence, the objects of organizational and economic support of financial stability systemic banks; structural changes and financial imbalances in the

**Banking regulation tools used to ensure the financial stability
of the banking system of Ukraine**

The name of the tool	Legal act, recommendations requirements	Availability of a tool in the system of financial stability Of Ukraine
Registration of banks and licensing of their activities	Law of Ukraine “On Banks and Banking”	Available
Establishing requirements and restrictions on activities of banks		
Application of administrative sanctions or financial nature;		
Supervision of banks		
Providing recommendations on the activities of banks		
Establishment of mandatory economic standards:	Instruction on the procedure of regulation activities of banks in Ukraine	Available
Minimum amount of regulatory capital of the bank (H1)		Made changes from 17 June 2016 to 2024.
Normative minimum regulatory size capital (H1)		Available
Sufficiency (adequacy) ratio regulatory capital (H2)		
Fixed capital adequacy ratio (H3)		
Instantaneous liquidity ratio (H4)		
Current ratio (H5)		
Short-term liquidity ratio (H6)		
Maximum credit size ratio risk per counterparty (H7)		
Standard of the maximum aggregate size loans, guarantees and sureties provided to insiders (H10)		
The norm of investing in securities separately for each institution (H11)		
Standard of the total amount of investment (H12)		
Reserve buffer (conservation) capital		Potential for implementation from January 1 2020 to 2023.

(End of Table 3)

The name of the tool	Legal act, recommendations requirements	Availability of a tool in the system of financial stability Of Ukraine
Dynamic redundancy	Basel III Agreement	Absent in the legislative framework of Ukraine
Reserve requirements for banks	Law of Ukraine "On Banks and Banking"	Available
Rates of contributions to reserves to cover risks from active banking operations;		
Interest rate policy		
Bank refinancing		
Correspondent relations		
Management of gold and foreign exchange reserves, including foreign exchange interventions		
Operations with securities on the open market		
Import and export of capital		

banking system; the effectiveness of the functions of the banking system; financial relations between the subjects of the IBC market. Based on the definition of "system", there are relationships between the main elements of the system of organizational and economic support of financial stability of the banking system. Their nature can be determined by constructing a scheme of interdependence between the purpose, tasks, subjects, objects, functions, principles and tools of banking regulation in the context of achieving financial stability of the banking system.

4. Results

For the first time, the concept of monitoring was proposed by a special commission of the Scientific Committee on Environmental Problems, according to which monitoring was defined from the standpoint of three main provisions: systematic monitoring of the state of the environment; identification of possible changes in environmental conditions; control of such changes and implementation (determination) of measures to manage

the state of the environment. The concept of “monitoring” entered the scientific literature relatively recently (early 70’s of XX century), but took an important place in the process of socio-economic research, became a method of creating tools for monitoring, evaluation, forecasting and management of all sectors.

Monitoring in modern conditions serves as a method of studying and analyzing socio-economic situations, a way to carry out organized systematic monitoring of the course and qualitative changes in the country as a whole or its components (eg regions), their impact on specific research objects, identifying critical points growth and prevention or elimination of the latter and the development on this basis of mechanisms for further development of society, its individual elements. Thus, monitoring is a universal tool of strategic management and can be used in relation to various spheres of public activity, which ultimately determines the object of observation, goals and list of tasks. According to researchers L.K. Voronovoyi and M.P. Kucheryavenka, the concept of “monitoring” is identified with the concept of “observation”. They emphasize that observation (monitoring) is a general tracking of the financial activities of a controlled entity. Savchenko L.A. notes that monitoring involves the systematic collection of information that can be used to improve the management process of the controlled entity, decision-making as a feedback tool. According to O.P. Orlyuk, monitoring is a method of financial control, which involves constant acquaintance with the general state of financial and economic activities of the object of control, the implementation of management decisions. Its main purpose is to identify signs that may indicate the presence of financial or other violations, and to draw the attention of the object of control to cause violations in any form. Observations – Monitoring acquires economic nuance in the English-Russian dictionary, ed. I.F. Zhdanovoyi as current control, monitoring of the technological process, the inflow of resources. In this case, we are talking not only about pure observation, but also about the possibility and necessity of control measures to maintain quantitative and qualitative parameters of management. After all, they are the ones who, in the end, make it possible to increase the efficiency of business entities by conducting thorough observations.

In general, monitoring can be carried out at two levels: at the lower level – as a system of information about the state and potential of the object

of study; at the top – as a control system, which provides for the addition of the lower level of the functions of regulating the state of the object, ensuring its certain necessary state.

T.A. Burova notes that monitoring is a universal tool for generating information about the object of study, including control, which allows it to be used in relation to various economic objects.

The research of I.O. Blanka, which defines monitoring as a mechanism for continuous monitoring of controlled performance of the enterprise, determining the size of deviations of actual results from those expected and identifying the causes of these deviations. Based on this definition, I.O. Blank proposes to consider monitoring as the basis of financial controlling (its active part), as the monitoring methodology is limited to determining the deviation of the main parameters of the financial activities of the enterprise and identifying the causes of such deviations. This methodology is aimed at implementing the control function and needs to be supplemented, as it does not reveal such aspects of monitoring as the interpretation of research results in order to better perceive them and short-term forecast, which is the basis for effective management decisions.

Based on a critical analysis of various approaches, V.Ya. Vovk proposed the following definition of the economic category “environmental monitoring” – a permanent system of monitoring the state of environmental factors, their assessment, forecasting trends in the studied object or its activities due to their impact and justification of management decisions aimed at adaptation to change the external conditions of operation.

The variety of interpretations of the essence of the concept of “monitoring” is explained by the use of this tool in various spheres of public activity. As banking is a rather complex and multifaceted area in the economic system of relations, the use of monitoring in the banking sector, in particular in the context of ensuring the financial stability of the banking system, is necessary and relevant in today’s economic and political imbalances.

Features of the use of monitoring in the banking sector are reflected in the concept of “banking monitoring”.

Kyrychenko O.A. and Mishchenko V.I. complement the definition and interpret “banking monitoring” as a system of continuous monitoring of all controlled limits and standards, determining the size and causes of

deviations from actual standards, the reasons for these deviations and management decisions.

It is advisable to consider monitoring from the standpoint of functionality and from an organizational point of view. According to the first approach, monitoring the stability of the banking system should be understood as an information system that covers monitoring (the main characteristic of monitoring is its continuity) the level of stability of the banking system, analysis, evaluation and forecasting of long-term stability. From the organizational point of view, monitoring the stability of the banking system is considered as a system. Therefore, like any system, monitoring should cover certain elements that interact and are influenced by internal and external factors.

Haryahoyu L.O. the term “credit risk monitoring” is proposed to mean the procedure of systematic monitoring of changes in credit risk at the level of the bank’s loan portfolio and individual borrowers and other indicators of credit risk in order to minimize, manage and control, identify dynamics and forecast credit developments. It is proposed to monitor not only the risk indicators, but also to take into account what factors affect its dynamics.

Zinchenko V.O. in its study, monitoring the stability of the banking system is considered from a functional and organizational point of view. Monitoring the stability of the banking system within the first approach, the author considers as an information system that includes continuous monitoring of the level of stability of the banking system, its analysis, evaluation and forecasting to make effective decisions to ensure the stability of the banking system; within the second – defines it as a system with a certain set of elements, which includes: purpose, object, subject, subject and mechanism. Thus V.O. Zinchenko notes that the main purpose of monitoring the stability of the banking system is to prevent crises. It is based on constant monitoring of the banking system in order to identify factors that affect or may affect its stability, determine the relationship and interdependence of these factors and take appropriate and timely corrective action. Issues of monitoring the financial stability of the bank were considered in the work of H.M. Azarenkovoyi and O.H. Holovko. The authors note that the economic orientation of monitoring the financial stability of the bank should reflect qualitative changes in the development of the bank, be a means of comparing the functioning of the bank, both

in terms of different time intervals and in terms of the selected system of banking indicators. The economic orientation of monitoring the financial stability of the bank should reflect qualitative changes in the development of the bank, be a means of comparing the functioning of the bank, both in terms of different time intervals and in terms of the selected system of indicators.

Thus, the analysis of the considered definitions of the concept of “monitoring” in different areas of activity, in particular, in banking, allows us to note that in the considered interpretations there are no fundamental differences, they complement each other. The next is the principle of multifunctionality, which takes into account the complexity and versatility of banking and involves monitoring the various components of assessing financial stability. At the same time, it should be borne in mind that monitoring should be based on the principle of economy and ease of construction, ie the number of indicators for assessing financial stability should be limited in order to obtain more timely, operational and quality information. The analysis of the given interpretations of monitoring in various spheres also allowed us to conclude that most scientists reveal the peculiarities of its implementation through the main stages, which are the assessment, control and forecast of the condition of objects. However, depending on the objects of monitoring, some economists provide some suggestions for improving this process. V.Ya. Vovk draws attention to the fact that in the process of forming the information base of monitoring it is necessary to clearly understand the directions and relationship of information flows that describe the state of the object of study, which, in turn, will develop a system that will ensure accurate and operational primary information on the state of the object of monitoring.

At the same time, it should be borne in mind that monitoring should be based on the principle of economy and ease of construction, ie the number of indicators for assessing financial stability should be limited in order to obtain more timely, operational and quality information. The analysis of the given interpretations of monitoring in various spheres also allowed us to conclude that most scientists reveal the peculiarities of its implementation through the main stages, which are the assessment, control and forecast of the condition of objects. However, depending on the objects of monitoring, some economists provide some suggestions for improving this process.

V.Ya. Vovk draws attention to the fact that in the process of forming the information base of monitoring it is necessary to clearly understand the directions and relationship of information flows that describe the state of the object of study, which, in turn, will develop a system that will ensure accurate and operational primary information on the state of the object of monitoring. Based on the systematization of theoretical aspects of financial stability of the banking system, which have been studied in the works of domestic and foreign experts on the subject, its content has been deepened. Under the financial stability of the banking system is proposed to understand the complex characteristics of its state, which determines the ability of the banking system over time to absorb the negative effects of external and internal factors, constantly and effectively perform its functions while maintaining its integrity and organization, financial stability. The revised definition takes into account a set of key features that reveal the content of financial stability – relative nature (resistance to financial instability, shock, panic), the relationship with the functional purpose of the system, dynamism (taking into account the impact of time on maintaining structure and functionality) and emphasizes attention to the internal organization of the banking system. As a result of the study of economic categories “financial stability” and “financial stability” it was concluded that their essence is close in terms of determining the ability of the banking system to fully perform its functions, ability to absorb shocks, overcome shocks, recover from shocks and imbalances. implies a change in financial performance) and return to equilibrium. According to the criteria of taking into account the identification features of the system and the aggregation of analytical data, a critical analysis of approaches to assessing the financial stability of the banking system. Emphasis is placed on the fact that none of the considered approaches to assessing the financial stability of the banking system fully takes into account the presence of complex links between its elements, features of the internal organization, place in the economy, main functions. Based on the deepening of the content of banking regulation, its impact on ensuring the financial stability of the banking system has been proven. A system of organizational and economic support for the financial stability of the banking system has been developed. The current system provides for the financial stability of the banking system at two levels: macro-level – the banking system as an object with systemic properties;

micro-levels – banks as structural elements of the banking system. The peculiarities of the functioning of the developed system of organizational and economic support of the financial stability of the banking system are taken into account and specified in its elements: goals, objectives, subjects, objects, principles, functions, tools.

According to the study of the essence of monitoring and the specifics of its use in banking practice, it is determined that monitoring the financial stability of the banking system is a process of continuous monitoring (collection and accumulation of information), processing and analysis of financial stability indicators at macro and microeconomic levels. decisions and forecasting the future development of the banking system, its dynamic movement. The following stages of monitoring the financial stability of the banking system are identified: formation of the analytical basis of the study (collection of information and calculation of partial and consolidated indicators for assessing the financial stability of the banking system and banks separately); comparison of actual evaluation results with data from previous years; comparison of calculated values of partial indicators with critical (threshold) ones, signaling the presence of crisis tendencies; analysis of the causes and consequences of the identified deviations of indicators; substantiation of dominants in ensuring the financial stability of the banking system, identifying prospects for its improvement and changing the levels of financial stability of banks.

5. Status and current trends in the functioning of the banking system of Ukraine

Effective functioning of the banking system is one of the main conditions for economic development. Ukraine's banking system has already survived serious crises: 1998, 2004, 2008 and 2013–2015. Today, banks are showing good profitability, but the quality of their loan portfolio, especially in state-owned banks, is extremely low. Given the instability of Ukraine's economic development, the global economic slowdown, there is a risk of a new crisis in Ukraine's banking sector. That is why it is important to regularly analyze the financial condition of banks, in order to timely identify the crisis-causing factors of the banking system. 2018–2020 were successful for the banking system. The profitability of banks in 2020 was the highest for the entire period of its operation. Return on capital in the sector reached

34%. This was made possible both by the rapid growth of operating income and the lowest allocation to reserves for assets in decades. Last year, due to a slowdown in inflation, a cycle of reducing the key NBU rate began. Commercial rates on hryvnia deposits and loans also began to decline. After the financial crisis of 2008–2009, the largest number of operating banks was in 2009 – 184 institutions, but in the following years their number gradually decreased. Since 2014, under the influence of the devaluation of the hryvnia, as well as political instability in the country, a significant number of banks have faced problems, many of them according to the NBU decision to liquidate, so as of 01.01.2018 the number of operating banks was 82 units., which is 93 financial institutions less than in 2008. Currently, there are 75 banks in Ukraine – more than twice less than 10 years ago. At present, the cleansing process has been completed and the situation has returned to a new state of equilibrium.

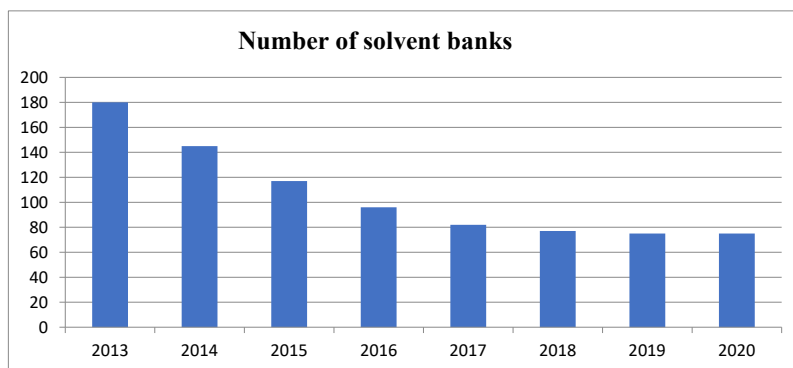

Figure 1. Number of solvent banks

As of the end of 2020, there were 75 solvent banks in Ukraine. 4 of them are state-owned – Privatbank, Ukrgasbank, Ukreximbank, Oschadbank. It should be noted that among this number are 20 banks with 100% foreign capital. The banking system has undergone more than just quantitative changes. Analysis of the profitability of banking institutions in Ukraine as a whole over the past ten years shows that the total income of banks during 2010–2020 increased by UAH 82 billion, which was due to an increase in interest income by UAH 52.4 billion, and at the expense of

commissions – by UAH 31.3 billion. The total increase in income was accompanied by an increase in all its components. Thus, we can conclude that the overall assessment of the dynamics of bank income was positive. The most negative financial result in the banking system was in 2016 and on 01.01.2017 amounted to UAH – 159.3 billion. But since 2018, the banking system has been showing profitability. The net financial result as of January 1, 2020 amounted to UAH 17.3 billion. This was facilitated not only by the NBU’s tight monetary policy and high interest rates, but also by a more prudent credit policy of the banks themselves. A significant increase in the profitability of the banking system was made possible by reducing contributions to reserves with a steady increase in interest and commission income. The main evaluation indicator of the activity of banking institutions is the relative indicator – return on assets and return on capital.

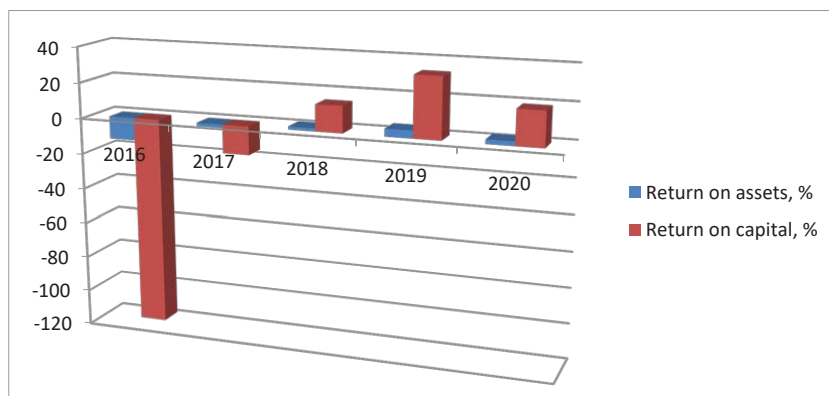

Figure 2. Efficiency of the banking system of Ukraine

Systemic risks to the financial stability of the banking system are at a medium level. This is confirmed by the dynamics of indicators of financial stability of banks. There is a decrease in the ratio of non-performing loans in banks’ portfolios from 58% in 2018 to 49.3% in 2020. In previous years, 2016–2018, the value of this indicator increased to 60.2% and was the reason for the deterioration of the quality of banks’ assets, as a result, the NBU declared a significant number of banks insolvent. The reasons that led to the emergence of problem assets in the banking system are the

devaluation of the hryvnia, which led to a nominal recalculation of problem loans and a real decline in the financial condition of borrowers and others.

To confirm the existence of systemic risks, the Z-score was calculated, which is used by experts from the World Bank and the IMF as an indicator of the stability of the banking system due to the ratio of losses of the banking system due to internal or external shocks and equity. The calculated data show the duration of the crisis in the banking system of Ukraine. The period from 01.01.2005 to 01.01.2009 can be defined as pre-crisis, when the value of the indicator was constant with the maximum value of 0.9 as of 01.01.2008. During 2009, the development of crisis phenomena of such an intense nature took place that the value of the Z-score decreased to -2.3 units. Starting from 2010, the gradual recovery of the banking system began under the influence of a number of external favorable factors and internal cleansing, as a result of which as of 01.01.2013 the indicator became positive and amounted to 0.3. This value was lower than the pre-crisis one, but at the same time it showed positive tendencies of post-crisis recovery. In 2013, the banking system of Ukraine, which only partially overcame the effects of the banking crisis, suffered significant external shocks, which led to a significant decrease in the value of the Z-score to -6.8 as of 01.01.2017. The data on the dynamics of this indicator confirm the conclusions about systemic risks, and we can see that the banking crisis of 2014–2015 was much deeper and longer, and its effects are just beginning to recover, as the value of the indicator on 01.01.2019 returned to pre-crisis levels. Current trends in the development of the banking system of Ukraine are most fully revealed in the process of analyzing the main indicators of the banking sector. In Figure the dynamics of distribution of net assets by groups of banks in UAH million is presented. for 2018–2020.

In 2018–2020, state and foreign banks accounted for the largest share in the structure of net assets of the banking sector. Net assets of state-owned banks increased from UAH 463 billion. up to UAH 569 billion; foreign banks from 413 billion UAH. up to UAH 525 billion As of 01.01.20, there was an increase in total and net assets. During this period, the increase in total assets amounted to UAH 707 billion; net assets – UAH 430 billion.

The gradual increase in the total assets of banking institutions in Ukraine is due to the resumption of lending to the country's economy.

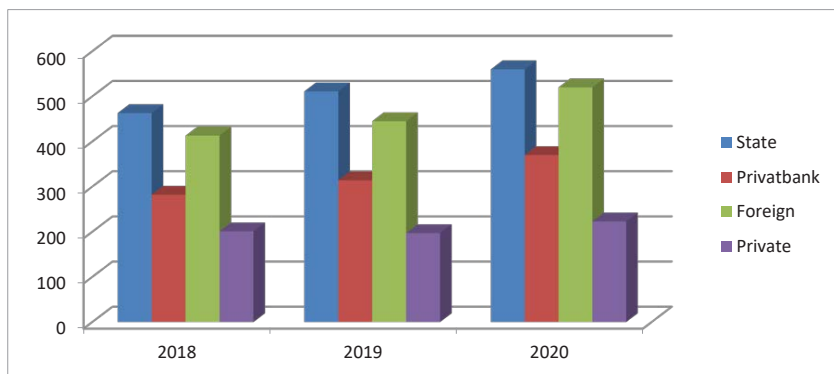

Figure 3. Dynamics of net assets of the banking sector of Ukraine, billion UAH

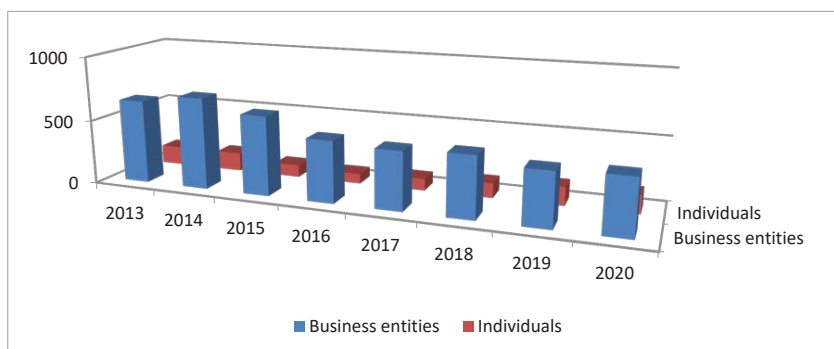

Figure 4. Net loans of the banking sector of Ukraine, UAH billion

During the study period, the amount of borrowed funds from individuals (by UAH 378 billion) and individuals (by UAH 239 billion) increased. This is a sign of financial stabilization of the banking system of Ukraine, as it indicates the gradual restoration of confidence of economic entities and individuals in financial institutions of Ukraine. The growth of the net hryvnia loan portfolio of individuals in 2020 slowed sharply due to quarantine restrictions in the first half of the year. In the second half of the year, lending for the purchase of housing increased significantly, growing at a faster rate than consumer lending. The average monthly volumes of new

Table 4
Dynamics of total assets of the banking sector of Ukraine, UAH billion

Indicator	2013 p.	2014 p.	2015 p.	2016 p.	2017 p.	2018 p.	2019 p.	2020 p.	Absolute deviation of 2020 from 2013, (+ ; -)
Total assets	1409	1477	1571	1737	1840	1911	1982	2205	+796
Including in foreign currency	513	667	800	788	755	719	718	745	+232

loans more than doubled compared to the first half of 2020 and 2019.

According to Figs. we see that within the study period for the overall structure of liabilities of the banking sector is characterized by an increase in the share of liabilities of state-owned banks. The share of liabilities of state-owned banks increased the most, by UAH 430 billion to UAH 515 billion (by UAH 85 billion) and foreign banks by UAH 112 billion.

Banks' liabilities increased during the period under review at the expense of customers and liquidity support from the NBU. At the same time, funds of economic entities and individuals remained the main source of funding for banks – 84.6% of liabilities. In 2020, hryvnia deposits grew rapidly. However, in the conditions of uncertainty caused by the pandemic, demand drivers were the driver of growth – their volumes increased by 49%. Funds of economic entities in hryvnia grew quite rapidly – 34.5%. The increase in hryvnia funds of business in banks with private capital was the highest. The level of dollarization of clients' funds decreased to 38.0%. One of the main conditions for ensuring the stable functioning of the banking system is a sufficient amount of equity, so consider the impact of capitalization on financial stability. Regulatory capital is one of the most important indicators of banks' activity, the main purpose of which is to cover the negative consequences of various risks that banks take in the course of their activities, and to ensure deposit protection, financial stability and stability of banking. It consists of fixed and additional capital.

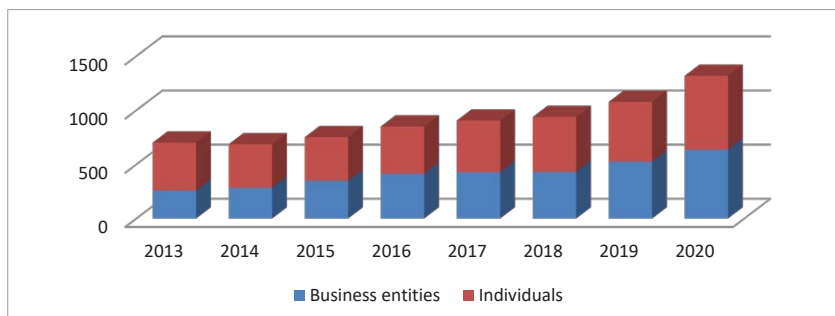

Figure 5. Let's analyze the dynamics of liabilities of Ukrainian banks during 2018–2020

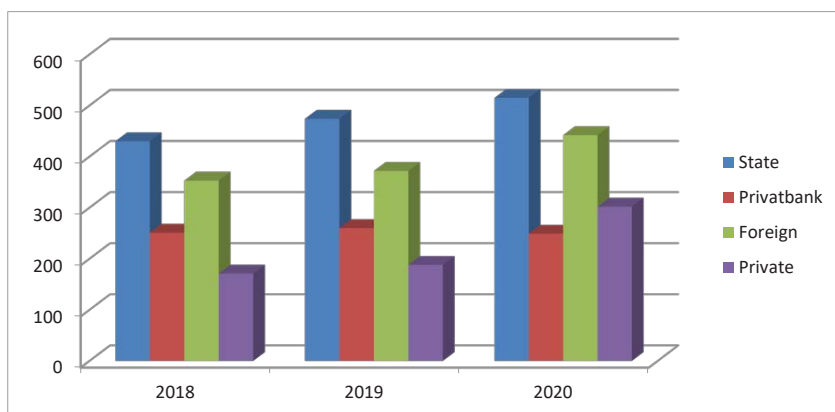

Figure 6. Dynamics of liabilities of the banking system by groups of banks, UAH billion

According to Figures 2-7 we see that in 2018 the regulatory capital of Ukrainian banks was at its lowest level and amounted to 126.11 billion UAH, but in the following years its volume increased by 54.62 billion UAH, as of 01.12.2020 is 180 737, UAH 3 million. The regulatory capital adequacy (H2) within the studied years ranges from 16.18% to 21.76%, ie corresponds to the NBU normative values of this indicator. The high value of this ratio is of course positive, but does not provide full capital adequacy in the process.

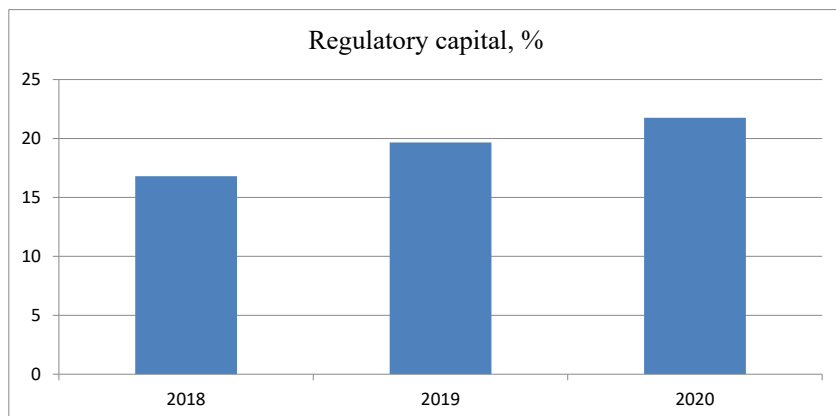

Figure 7. Regulatory capital, %

6. Evaluation of the efficiency of the banking system of Ukraine

An important indicator that characterizes the stability of the banking system is the direct receipt of profits in the course of its activities. The effective functioning of the banking system of Ukraine depends on ensuring stable profitability of banks in the process of their activities, because profit is one of the main components of the reliability of the banking sector. According to the NBU report, the banking system during 2016–2017 was in a state of unprofitability, and from 2018. gets positive results. According to the NBU's estimates of banking institutions, their profitability reached its highest level in 2019 and amounted to UAH 58,356 million. For the period 2018–2020, banking institutions of Ukraine, despite the crisis, show positive results. Thus, during the study period, the positive values of return on assets ranged from 1.69% in 2018 to 2.44% in 2020; return on capital, respectively, from 14.67% in 2018 to 19.33 in 2020.

The profit of the banking sector in 2020 is almost a third lower than in 2019 and amounted to UAH 41.3 billion. The annual growth rates of net interest and commission income were the lowest in the last four years. Contributions to reserves were three times higher than in 2019. These factors are due to the reduction of lending in the first half of 2020 and the deterioration of the solvency of certain sectors and companies amid the unfolding crisis related to the pandemic.

Table 5

**Estimation of profitability of the banking system of Ukraine,
billion UAH**

Indicator	2016 p.	2017 p.	2018 p.	2019 p.	2020 p.	Absolute deviation 2016 from 2020, +/-
Net interest income	44,2	53,0	73,0	20,8	22,4	-21,8
Net commission income	24,2	27,7	37,8	11,7	14,2	-10
Deductions to reserves	198,3	49,2	23,8	3,6	9,0	-189,3
Net profit /loss	-159,4	-26,5	22,3	58,35	41,3	+200,7

Assessing the return on bank assets allows you to determine the effectiveness of managers of the banking institution, as its sufficient importance indicates the implementation of effective and efficient management of assets and liabilities of banks, but may be one of the consequences of high risk operations. Its use makes it possible to assess the effectiveness of the bank's investments in the base for the formation of profits of its assets.

The rate of return on capital is the ratio of the bank's net profit to the average value of the bank's capital over the period and characterizes the

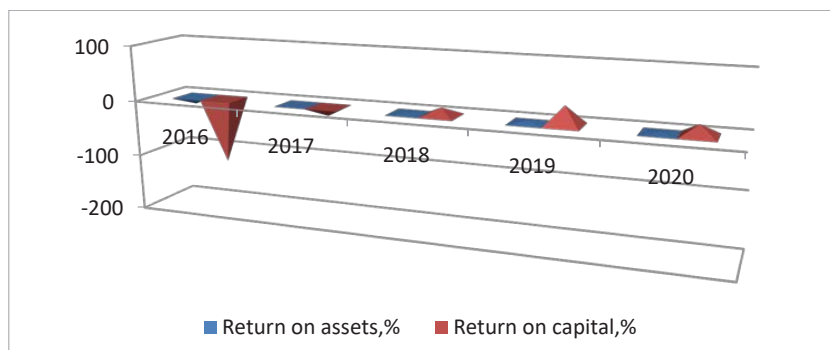

Figure 8. Efficiency of the banking system of Ukraine

efficiency of capital invested in the bank's business. The value of the ROE indicator is to determine the level of return (in the form of net profit) from the shareholders' funds invested in the bank, as well as retained earnings directed by the bank to business development.

Thus, as a result of research we can conclude that the healthiest and strongest banking system in Ukraine was in 2019, because the banking sector was capitalized, profitable and without any bankruptcy in the market, which was the main reason that Ukraine's banking system has the ability to confront the effects of the COVID-19 pandemic.

7. Finding

The properties of controllability and controllability of the process of interaction between the banking and real sectors of the economy, highlighted in the theoretical part of the work, are most evident when the ability to manage the accumulation, redistribution and efficient consumption of resources by private business begins to slip. In this situation, the role of state regulation as a direction in solving problems has grown. Today, many scientists and experts believe that in the new environment of financial and economic instability, solving a complex problem of transforming savings into investments with their reorientation in the field of expanded reproduction and modernization of fixed assets in the real sector is impossible without embedding incentives macro-regulation. Moreover, the experience of a number of countries in America, Asia and Europe (1997–2009) shows the effectiveness of such a regulatory paradigm. In 2010, the Basel Committee published the Third Basel Accord, which is a key piece of legislation aimed at improving the quality of risk management and capital management of financial institutions. This document establishes new minimum capital requirements, new liquidity ratios and leverage, as well as new methods and approaches to measuring and assessing risks. In addition, the document introduces stricter standards of banking supervision, as well as increased requirements for information disclosure and risk management. A recent study by Ya. Putnis on banking supervision emphasizes that banking regulation has never had such a high profile and has never been as important as it is today. The subject of banking regulation has affected the agenda, as politicians have realized the damage that insolvent banks can do to national and regional economies. YA. Putnis states that national banks often face the problem of

lack of portfolio supervision in all banks in their country, and therefore do not potentially identify the concentration of risks in the country's banking system. According to Dzh. Barsa i Dzh. Hana, "regulation refers to a set of laws and regulations applicable to banking, and supervision is defined as the monitoring of banks and the implementation of banking regulations". At the same time, the authors point out that the role of the banking business has changed, and therefore the way in which banks are regulated and controlled has changed. Kherrinh ta Karmasi, authors of *The Structure of Cross-Sector Financial Supervision*, analyze changes in banking supervision and focus on an integrated approach and show that crisis management may not be an adequate replacement for the traditional model in which prudential supervision takes place within the central bank. According to analysts at KPMG, the supervisory pressure has hit Central and Eastern European countries hardest, trying to make adequate profits and demonstrate that they have a viable and stable business regime. Withdrawal of assets and risks of balance sheet deficits push most banks to comply with existing regulatory requirements for capital and liquidity in the EU. However, there are also problems with the profitability of banks, the increase in costs, which affects the maintenance of a stable future. The authors of the article "Financial Supervision in Central and Eastern Europe" define financial supervision strategies, one of which is comprehensive supervision, the effectiveness of which is associated with the establishment and unification of procedures to reduce the cost of supervision, facilitate contacts with supervised entities. There are also various forms of criticism of the integrated model, which they believe serves the multifunctional service of the financial group and remarks that by integrating all financial supervision into one supervisory body, the latter becomes too big, too unmanageable and too powerful. Foreign scientific work on the formation of the regulatory environment of the European Union, as well as on the study of banking management belong to Western practicing analysts Timoti Kokhu i Skotu Makdonal'du.

D. Noyberher identifies competition policy in the banking sector as an additional group of supervisory banking measures and identifies measures for preventive supervision, which are aimed at avoiding bankruptcy of the bank. They include capital requirements, liquidity and diversification, provision of information, prohibition of certain types of banking operations, instructions on reporting. This also includes licensing conditions, which

are crucial in the supervision. K. B'orner believes that for this reason, discretionary regulation, which provides some freedom of action both in initiating sanctions and in their choice, should be equated with qualitative regulation, which is associated with the method of risk assessment (causes). According to V. Hryuninha, traditional banking analysis is based on quantitative methods of assessing the state of the bank, including relative indicators such as liquidity ratios; capital adequacy; quality of the loan portfolio; shares of the loan provided to persons authorized and related to the bank; credit risk of potential losses and open currency positions. The method of banking supervision of the Basel Committee on Banking Supervision, which is implemented in the Basel II agreement, is an example of popularizing indicative regulation instead of administrative regulation.

The analysis of literature sources devoted to the study of banking supervision in Central and Eastern Europe shows that the banking supervision system consists of elements of the regulatory environment; availability of banking supervision institutions; formed requirements of banking supervision in accordance with the development of the banking system (standards, indicators, ratios, rules, licenses); forms of banking supervision. Elements of the banking supervision system are interconnected, as they work to achieve a common goal: the analysis and management of bank risks and compliance with prudential standards of banking supervision. The main directions of development of European supervision remain the unification of European banking rules, which simplify the procedure for conducting banking supervision within the European Union. Theoretical and practical questions about the evolution of banking supervision in Central and Eastern Europe in the concept of risk-based approach remain relevant. According to the Law of Ukraine "On the National Bank of Ukraine" in Art. 1 states that "banking supervision is a system of control and active and orderly actions of the National Bank of Ukraine aimed at ensuring compliance by banks and other persons in respect of which the National Bank of Ukraine supervises the legislation of Ukraine and established standards to ensure stability of the banking system and protection of interests depositors and creditors of the bank; Banking regulation is one of the functions of the NBU, which is to create a system of rules governing the activities of banks and determine the general principles of banking, the procedure for banking supervision and liability for violations of banking laws. A similar definition

of banking supervision is given in Art. 67 of the Law of Ukraine “On Banks and Banking”. This article states that “the purpose of banking supervision is the stability of the banking system and the protection of the interests of depositors and creditors of the bank regarding the security of storage of customers’ funds in bank accounts.”

According to the provisions of Art. 4 of the Law of Ukraine “On Banks and Banking” the National Bank of Ukraine regulates and supervises banking in accordance with the Constitution of Ukraine, this Law, the Law of Ukraine “On the National Bank of Ukraine”, other legislative acts of Ukraine and regulations of the National Bank of Ukraine. The National Bank of Ukraine determines the features of regulation and supervision of a systemically important bank, a bank that has the status of a Settlement Center for servicing contracts in financial markets, taking into account the specifics of such banks. Domestic scientific approaches in the interpretation of banking supervision generally adhere to the above-mentioned legal provisions. Disagreements arise primarily when defining the essence of the concepts of banking regulation and supervision. In particular, in the textbook authored by V. Mishchenko and other authors, the regulation of banking is understood primarily as the creation of an appropriate legal framework, ie the development and adoption of laws governing banks, as well as the adoption of relevant institutions authorized by the state, regulations governing banks in the form of regulations, instructions, directives. Legislation and regulations define the limits of banks’ behavior that contribute to the reliable and efficient functioning of the banking system. Banking supervision is defined as “monitoring of processes taking place in the banking sector at various stages of the functioning of banks, namely: the creation of new banks and their institutions, the activities of banks, reorganization and liquidation of banks. To this end, the supervisory authority has the power to apply coercive and non-coercive measures of influence to banks”.

An analysis of research on banking regulation and supervision suggests that these are interrelated concepts that have several important components. First of all, they are mandatory for banks and banking groups in the rules of banking operations, accounting and reporting, organization of internal control, preparation and submission of accounting and statistical reporting. The second element is these two interrelated processes, which set special

standards for banks in their activities and which are aimed at limiting their risks and protecting the interests of customers and depositors, as well as society as a whole. Such standards include the minimum amount of regulatory capital; regulatory capital adequacy ratio; regulatory capital ratio to the bank's liabilities; liquidity standards. The development of banking systems has been carried out for a long time under the influence of historical, economic and political factors, as well as legal and judicial practices.

E. Keyn described the relationship between banking regulators and banks as a dialectic of regulation or a model of struggle. His idea is the Hegelian concept, which consists of a three-stage structure of any process of change: the first stage – the thesis; another – the antithesis; the third is synthesis. The collision of thesis and antithesis leads to synthesis. Synthesis then becomes a new thesis in the fight against the next antithesis, which gives a new synthesis. In the area of finance, the struggle is also continuous, as regulation can be seen as taxes that banks seek to avoid. The reason for the struggle is the inconsistency of the goals set by regulators and banking structures. The purpose of regulators is to maintain security, stability and a viable (competitive) financial system; The task of bankers is to increase the value of certain variables – capital, profits, etc. Banks are trying to overcome the restrictions of regulators, trying to find ways to avoid the implementation of regulations and laws. In response, supervisors are stepping up and the fight begins again. This confrontation stimulates the emergence of financial innovation (as a way to avoid constraints), and also explains the process of innovation in the financial system. The benefits of regulatory measures from the point of view of their costs are difficult to measure, as the benefits are often short-term, while the costs are very long-term.

The experience of the financial crisis of 2007–2009 showed that there is a relationship between the structure of compensation of financial firms and excessive risk-taking by their employees. The main problem was that modern banks tend to reward managers for risky strategies, but do not charge penalties for decisions that lead to bank failures, the destruction of the financial system and government infusions, and the loss of taxpayers. Ethical failures and systematic shortcomings in the context of the 2007–2009 financial crisis suggest that the forthcoming dialogue of regulators on banking regulation policy is unlikely to ignore the importance of corporate culture. The latter's problem in the banking business has arisen

in connection with the resumption of discussions on resolving two issues of restoring public confidence in the banking system and improving financial stability.

One of the key areas for the formation of risk-oriented banking supervision and regulation in CEE countries is the introduction of capital requirements. The main focus in this direction remains the provisions of the Basel Committee, Basel III, published in December 2010 and revised in June 2011. At European level, the implementation of these standards was planned for 2013-2019. The implementation consisted of the so-called CRDIV package: – CRR – Capital Requirements Regulation (EU) 575/2013; – CRD – Capital Regulation Directive 2013/36 / EU – CRDIV.

CRR is direct legislation, ie this provision is fully implemented and applied in all EU member states, extends the norms that have not been regulated by the CRDIV and applies to Pillar I Basel. CRDs are principles and norms that reflect the Basel II and Basel III norms on capital standards and are implemented through the adoption of national laws.

The main purpose of these two documents is to strengthen capital requirements in response to global financial crises, promote the sustainability of financial institutions and the banking sector. The tasks of ensuring the stability and reliability of the banking system must be addressed at both the macroeconomic and microeconomic levels. At the macroeconomic level, an important component of economic activity (in terms of monetary theory) is the amount of money in circulation. Other mechanisms that ensure the coordinated functioning of components at the macroeconomic level are interest rates and the volume of bank loans. Despite the fact that in the modern economic system, commercial banks are not the only ones that perform the function of financial intermediation in financial markets, but their role in this process is still extremely important.

Thus, the regulation of banking activities protects the money supply and gives central banks the lever with which they influence bank reserves, interest rates and lending activities of banks. The socio-economic nature of banking supervision is to promote banking supervision of the financial system, which is achieved through the formation of requirements for banking supervision by individuals and households (insurance and lending, profitability and regularity of the banking system) and the state through macroeconomic requirements (economic and social protection, ie laws,

rules, national definitions), control over the national system of financial policy (macroeconomic policy, the creation of an appropriate regulatory environment for banks). The solution of such requirements by banking supervision should be based on the world experience of banking supervision through the involvement of the best methods and practices of banking supervision.

It should be noted that in the regulatory environment and, in particular, in the EU Directives there is no definition of financial stability. Economists also differ on a common approach to its interpretation. However, there are common elements that can be used to understand financial stability, namely: a safe and well-functioning financial environment, no shocks or no financial instability. In this regard, everything that helps to make financial structures safer and less vulnerable to shocks is aimed at financial stability. In this sense, it is banking supervision that contributes to achieving this goal, because it monitors financial instruments and indicators that are aimed at preventing or resolving problems of financial instability of banks. In order to increase the resilience of banks in times of financial and economic instability, creating a reserve of capital to increase the ability to withstand risks, the National Bank of Ukraine sets requirements for banks to form capital buffers, which was supplemented by a new chapter of the Instruction which came into force on January 1, 2020, namely: buffer of stock (conservation) of capital (planned to be introduced from 01.01.2020) and countercyclical buffer (by decision of the regulator). It is said that the bank forms capital buffers, namely the capital reserve (conservation) buffer, countercyclical buffer.

Banks must form capital buffers above the normative value of the fixed capital adequacy ratio (H3). The capital reserve (conservation) buffer is calculated from the total risk. The bank forms a buffer of stock (conservation) of capital, starting with: January 1, 2020 – in the amount of 0.625%; January 1, 2021 – in the amount of 1.25%; January 1, 2022 – in the amount of 1.875%; January 1, 2023 – in the amount of 2.5%. The countercyclical capital buffer is calculated from the total amount of risk in the amount of 0–2.5%. The size of the countercyclical capital buffer is set by the decision of the Board of the National Bank in the case of significant lending activity of banks, taking into account the risks associated with excessive credit growth. This information is posted in advance on the page

of the official website of the National Bank and should contain information, in particular on the size of the buffer, the date of introduction of the buffer in the prescribed amount. Comparative characteristics of capital structures of banks in Ukraine and EU countries are presented in table 6.

Table 6

**Comparative characteristics of capital structures
of banks in Ukraine and EU countries**

Capital structure of Ukrainian banks (H2> 10%). The ratio of OK to DC, as 50/50			EU capital structure (minimum value 8% + preservation buffer = 10.5%). Capital ratio 1 year. to the capital of 2 years, as 75/25		
1. Tier 1 capital (fixed capital). Components: authorized capital, issue difference, fin. help of shareholders, funds created at the expense of profit 2. Level 2 capital (additional capital). Ingredients: – profits of previous years. – income for the current year, reduced by overdue and uncollected > 30 days accrued income, – subborg. Capital = OK + DK reduced by direct investment in other institutions more than 10% and other securities (issued by out-of-listing banks that are not listed on the stock exchange), sub-debt.			1. Tier 1 capital (Tier 1) (OK1r. + DK1r.) Components: fixed capital (ordinary shares), issue income from ordinary shares, retained earnings, funds (reserve and others) created by profit. Additional level 1 capital – perpetual capital instruments, sub-debt (in the case of a trigger event OK less than 5.125%) is converted into instruments OK1, or written off, 2. Tier 2 capital. Components: authorized capital (preferred shares), issue income on preferred shares, term capital instruments (more than 5 years without long-term repayment incentives)		
NBU capital ratios,%			Capital ratios for BCBS,%		
Instruction № 368					
<i>Types of capital</i>	<i>Current standard, %</i>	<i>Planned standard for January 1, 2019, %</i>	<i>Types of capital</i>	<i>Standards in Basel II, %</i>	<i>Standards in Basel III, %</i>
Level 1 capital	5	7	Fixed capital, 1 year	–	4,5
Level 2 capital	5	3	Level 1 capital	4	6
Capital	10	10	Level 2 capital	4	2
			Capital	8	8
			Conservation buffer	–	2,5

As can be seen from table. 6, there are fundamental differences between the capital structure of EU banks and Ukrainian banks. The main differences are as follows.

1. Capital structure. In the EU, the share of tier 1 capital, which plays a key role in the preservation of the bank, has increased (75/25), ie the ability of banks to absorb losses has been increased. In Ukraine, this show is at 50/50 at the level of Basel II. According to the NBU Instruction № 368, it was planned to raise the ratio of OK to DK from January 1, 2019 to 70/30. In our opinion, such changes will not affect the overall picture, as there are differences that are more fundamental.

2. According to the legislation of Ukraine, capital is reduced by the amount of direct investment only from the total amount of capital (OK + DK). In the EU countries, according to the norms of the Basel Committee, direct, indirect and synthetic investments are deducted from each relevant level of capital, both from Tier 1 capital and Tier 2 capital.

According to experts, in Ukraine there are strict approaches to valuation and capital instruments: for example, there are no hybrid instruments. However, the introduction of the accounting standard IFRS9 is gradually changing the psychology of reserve calculation. The main elements of the calculation become similar to the Basel standards – these are indicators of PD, LGP, EAD. The approach to the classification of financial instruments is also undergoing changes. These are instruments that measure depreciation and instruments that measure fair value. Each of the instruments has an assessment of impairment based on credit risk.

Shows the main stages of capital reform – in the EU countries introduced on January 1, 2016 conservation buffer (0.625%) with a gradual increase to 2.5% on January 1, 2019. In Ukraine, the conservation buffer in accordance with Instruction № 368 activated from January 1 2020 at the level of 0.625.

The legislation of Ukraine and regulations of the NBU of Ukraine do not provide for the use of tools of the 1st level of the SC in the event of a trigger event. A trigger event is a decrease in the Tier 1 adequacy ratio below 5.125%, or another value (over 5.125%), as determined by the bank in the relevant regulations and agreements. In the EU, Tier 1 instruments include perpetual instruments, the principal amount of which must be written off or converted into Tier 1 instruments in the event of a trigger event. After the

crisis of 2008, the countries of Central Europe (Great Britain, Switzerland) began to use these tools.

On June 3, 2016, the Board of the National Bank of Ukraine adopted Resolution № 338, which amended the Instruction on the Procedure for Regulating the Activities of Banks in Ukraine, approved by the NBU Board Resolution № 368. These changes determine the procedure for including financial assistance to shareholders. Thus, financial assistance of shareholders is included in the fixed capital of the bank with the permission of the National Bank of Ukraine provided that the funds received in cash and are non-refundable, non-credit, and the bank's ownership structure meets its transparency requirements set by the National Bank of Ukraine. In addition, the calculation of certain economic standards in terms of reducing credit risk by the amount of acceptable collateral has been clarified.

According to the Instruction on the Regulation of Banks in Ukraine, to measure liquidity risk, Ukrainian banks use the structure of assets and liabilities, which is built taking into account the terms of the transaction for each currency. To assess liquidity risk, a cash flow calendar is built – a schedule of interest payments and the principal amount of debt. It is similar to the revaluation calendar used to control interest rate risk, except that in the latter the date of the price change is of primary importance, in the cash flow calendar the emphasis is on the date of interest payment and the principal amount of debt. In order to monitor the liquidity of banks, the National Bank sets liquidity ratios: instantaneous liquidity (H4), current liquidity (H5) and short-term liquidity (H6). The instantaneous liquidity ratio (H4) is defined as the ratio of highly liquid assets to current liabilities of the bank, ie sets the minimum required amount of highly liquid assets to ensure the fulfillment of current liabilities during one transaction day. This indicator is calculated taking into account the balance on correspondent accounts opened with other banks and on correspondent accounts of other banks. The current liquidity ratio (H5) is defined as the ratio of assets with a maturity of up to 31 days (inclusive) to the liabilities of the bank with a maturity of up to 31 days (inclusive). This standard sets the minimum required amount of bank assets to ensure the fulfillment of current liabilities within one calendar month and is calculated taking into account the balance of placed and attracted funds on correspondent accounts opened with other banks and on correspondent accounts of other banks and interbank loans /

deposits placed with other banks and received from other banks. The short-term liquidity ratio (H6) is defined as the ratio of assets to liabilities with a maturity of up to one year. This standard sets the minimum required amount of assets to ensure the fulfillment of its obligations for one year and is calculated taking into account the balance of placed and attracted funds: on correspondent accounts opened with other banks and on correspondent accounts of other banks; on interbank loans / deposits placed with other banks and received from other banks. It should be noted that these indicators have not changed or reformed radically, although the banking system has gone through liquidity crises. The new capital requirements for banks were approved by the Resolution of the NBU Board dated 12.05.2015 № 312 “On Approval of Amendments to the Instruction on the Procedure for Regulating the Activities of Banks in Ukraine”. According to the Instruction, the minimum amount of regulatory capital of the bank (H1), which received a banking license before July 11, 2014, should be UAH 120 million – until June 17, 2016 and UAH 200 million – from July 11, 2017.

The Instruction also establishes the regulatory capital adequacy ratio (H2), which reflects the bank’s ability to pay its liabilities on time and in full. The higher the value of the regulatory capital adequacy ratio, the greater the share of risk borne by the bank’s owners and the lower the share of risk of creditors / depositors of the bank. The value of H2 is defined as the ratio of regulatory capital and weighted risk and solvency ratios of total assets and off-balance sheet instruments.

The normative value of the H2 coefficient for existing banks must be at least 10%. For banks that start operating, this standard should be: a) during the first 12 months of operation from the date of obtaining a license – not less than 15%; b) during the next 12 months – not less than 12%; c) in the future – not less than 10%.

Fixed capital adequacy ratio (H3) is defined as the ratio of fixed capital to the sum of assets and off-balance sheet liabilities, weighted by the relevant credit risk ratios. The normative value of the H3 standard must be at least 7%. The main reason for the global crisis of 2008–2009 was the underestimation of banks’ liquidity risks. In order to overcome and prevent these risks, the EU, together with the Basel Committee, has developed standards that have helped to overcome these problems – Basel III and the Directive – CRR and CRD. Until 2008, Ukraine did not use elements of

macroprudential policy in its financial policy, unlike in Central Europe, where, for example, in the United Kingdom in 1996 the first review of financial stability was published.

The implementation of these instruments in Central European countries has been quite problematic, as, for example, the deficit of highly liquid assets for LCR amounted to 1.7 trillion euros, and for stable financing – 2.9 trillion euros. But after the crisis, the share of highly liquid assets in internationally active banks increased. And the BCBS published its conclusions in 2016, six years after the launch of these instruments, which are important for the Ukrainian banking system. These findings are that, first, LCR requirements are more difficult for retail banks to meet and NSFR requirements for investment banks; second, LCR, unlike NSFR, is sensitive to assumptions; third, in the pursuit of a high LCR, a bank may worsen its risk profile. Finally, the implementation of the LCR does not mean that banks are resistant to liquidity shocks.

Banking regulation is the process of promoting financial stability through the use of special methods, tools, by establishing specific rules and regulations. Therefore, the functions of banking regulation are closely related to the conduct of monetary policy and the organization of the settlement system and have historically been carried out by central banks. Supranational banking regulation is a regulatory process carried out by world-class international organizations (IMF, IBRD, EBRD, BCBS).

Banking supervision is the control over the stability and stability of the banking system, which must adequately respond to global trends and reassess supervisory policy. From the standpoint of methodology, banking supervision should be understood as a set of methods, techniques, tools used by banking supervisors to monitor the performance of banks, the application of measures of influence and so on. Banking supervision is based on a constant analytical survey of banks and serves socio-economic needs, as there is a close relationship between risk analysis and banking supervision. In Western and domestic scientific sources, the issue of banking supervision is often identified with the analysis of the causes of banking risks and methods of their study. An analysis of the literature has shown that the study of risks has a long history, but the active study of financial risks began relatively recently – in the late nineteenth – early twentieth century.

Liquidity monitoring tools such as stress testing, debt concentration analysis and GAP analysis (liquidity gaps) are important for the formation of risk-oriented banking supervision. In Ukraine, the current liquidity standards are quite static and do not meet the requirements of the Basel Committee. The NBU planned to introduce LCR from 2018 in the test calculation mode (without requirements). In developing the LCR, the NBU takes into account the requirements of Basel and national characteristics – underdeveloped market of securities and highly liquid deposit assets (there are no quality corporate bonds and mortgage bonds). This is taken into account in the components of the liquidity buffer. The NBU took into account the stress scenario of 2014 as the basis for calculating the indicator, ie higher outflow rates for retail and corporate deposits than envisaged by the Basel Committee.

According to the Comprehensive Action Plan for the Implementation of the Financial Development Program in Ukraine, it is planned to improve the systems of regulation and supervision of the financial sector, continue the transition from compliance based supervision to risk-based supervision and oversight. preventive monitoring (from April 1, 2015 to December 31, 2016), as well as the introduction of new capital requirements for banks in accordance with the principles of Basel III and EU requirements (from January 1, 2015 to December 31, 2019).

These measures are possible only by complying with the requirements of the European Parliament and the Council of Europe, which aim to create a level playing field in the financial sector, strengthen the solvency and liquidity requirements of financial sector participants, introduce special requirements for capital, liquidity and other financial institutions, as well as improving the system of regulation and supervision of the financial sector.

According to international principles, an effective banking supervision system must have specific responsibilities and goals, operational independence, transparency, reliability, and resource base. Therefore, the implementation of these principles in the work of the national banking system is extremely important.

Currently, the analysis of the current state of the banking sector and the main regulatory aspects indicates the presence of problems that indicate a crisis in the banking system of Ukraine, in particular, in the system of banking regulation and supervision. Thus, according to the regulatory framework,

banking supervision in the system of the National Bank of Ukraine has a sufficient level of independence, but during the financial crisis, problematic issues regarding its functional and institutional components were identified.

8. Conclusions

The paper solves an important scientific and practical task of developing theoretical principles and methodological approaches, developing scientific and practical recommendations for improving the monitoring of financial stability of the banking system. The main conclusions and results obtained during the study are as follows.

Based on the systematization of theoretical aspects of financial stability of the banking system, which have been studied in the works of domestic and foreign experts on the subject, its content has been deepened. Under the financial stability of the banking system is proposed to understand the complex characteristics of its state, which determines the ability of the banking system over time to absorb the negative effects of external and internal factors, constantly and effectively perform its functions while maintaining its integrity and organization, financial stability. The revised definition takes into account a set of key features that reveal the content of financial stability – relative nature (resistance to financial instability, shock, panic), the relationship with the functional purpose of the system, dynamism (taking into account the impact of time on maintaining structure and functionality) and emphasizes attention to the internal organization of the banking system.

As a result of the study of economic categories “financial stability” and “financial stability” it was concluded that their essence is close in terms of determining the ability of the banking system to fully perform its functions, ability to absorb shocks, overcome shocks, recover from shocks and imbalances. implies a change in financial performance) and return to equilibrium.

According to the criteria of taking into account the identification features of the system and the aggregation of analytical data, a critical analysis of approaches to assessing the financial stability of the banking system. Emphasis is placed on the fact that none of the considered approaches to assessing the financial stability of the banking system fully takes into account the presence of complex links between its elements, features of the

internal organization, place in the economy, main functions. Based on the deepening of the content of banking regulation, its impact on ensuring the financial stability of the banking system has been proven.

A system of organizational and economic support for the financial stability of the banking system has been developed. The current system provides for the financial stability of the banking system at two levels: macro-level – the banking system as an object with systemic properties; micro-levels – banks as structural elements of the banking system. The peculiarities of the functioning of the developed system of organizational and economic support of the financial stability of the banking system are taken into account and specified in its elements: goals, objectives, subjects, objects, principles, functions, tools.

According to the study of the essence of monitoring and the specifics of its use in banking practice, it is determined that monitoring the financial stability of the banking system is a process of continuous monitoring (collection and accumulation of information), processing and analysis of financial stability indicators at macro and microeconomic levels. decisions and forecasting the future development of the banking system, its dynamic movement. The following stages of monitoring the financial stability of the banking system are identified: formation of the analytical basis of the study (collection of information and calculation of partial and consolidated indicators for assessing the financial stability of the banking system and banks separately); comparison of actual evaluation results with data from previous years; comparison of calculated values of partial indicators with critical (threshold) ones, signaling the presence of crisis tendencies; analysis of the causes and consequences of the identified deviations of indicators; substantiation of dominants in ensuring the financial stability of the banking system, identifying prospects for its improvement and changing the levels of financial stability of banks.

As a result of the analysis of the functioning of the banking system of Ukraine as a whole and on a separate example of Oschadbank JSC, we draw the following conclusions: 1. having analyzed the structure of the banking system of Ukraine, it is established that in Ukraine the existence of a two-tier structure of the banking system, the construction of which is similar to the European model, is enshrined at the legislative level. The main financial and economic indicators of the banking system of Ukraine

and Oschadbank JSC for the period from 2018 to 2020 are analyzed. It is established that during this period there was a stabilization of the number of banking institutions that demonstrated stable profitability. At the same time, banking institutions increased their assets, both national and in foreign currency. During the study period, the amount of lending to the banking system has not changed, although the amount of borrowed funds from individuals (from 508 to 683 billion UAH) and legal entities (from 430 to 635 billion UAH) has increased, which indicates confidence in the banking system Ukraine; The increase in certain indicators has led to profitable activities over the past 3 years, although the previous years 2017-2018. were unprofitable. Return on assets and return on capital of the banking system of Ukraine amounted to 2.44% and 19.22%. Features of functioning of JSC Oschadbank which is one of the systemically important banks of Ukraine, ranks first in terms of net loan portfolio and second among banks in Ukraine in terms of assets, and is the largest in Ukraine in terms of liabilities in the corporate sector and second in terms of liabilities in the retail sector. In 2020, compared to 2018, Oschadbank JSC increased its assets by 7.26%. The structure of assets was as follows: 46% – investment portfolio; 26% – loan portfolio; 28% – other assets.

The share of Oschadbank's loan portfolio in total assets is declining every year, due to the unstable financial situation in the country and the pandemic of coronavirus infection, which has a negative impact on economic activity, which leads to lower incomes and legal entities. provides opportunities to increase the volume of credit operations and expand the range of customers. In the structure of liabilities, the largest share is occupied by customer accounts, which during this period increased by 20.78%. This is due to the fact that Oschadbank JSC is one of the leaders in the domestic banking market in the dynamics of the retail deposit portfolio . Thus, in 2019 the bank maintained its market position (1st place in the market of liabilities of legal entities) and constantly worked on diversifying the customer base, primarily by attracting new customers from the private sector.

Oschadbank JSC received a net profit of UAH 2.8 billion, which is UAH 2.5 billion. more than in 2019. The profit was generated primarily from net interest income of UAH 8 billion, which is UAH 2.5 billion or 45.3% more than in 2019. Net commission income amounted to UAH 5 billion, which is UAH 0.8 billion or 18.1% more than in 2019. Trading

income of UAH 3.6 billion was generated mainly from transactions with financial instruments measured at fair value. Return on assets (ROA) of Oschadbank JSC as of 01.01.2020 has the highest indicator, which meets the recommendations and is 1.16. This indicates that the Sberbank's implementation of the strategy and tactics of asset growth is correct. The ROE (stability indicator) of Oschadbank JSC is 12.64% in 2020, and is close to the recommended one (15%). All these indicators have maintained a positive trend, despite the economic situation associated with the pandemic. According to the Comprehensive Action Plan for the Implementation of the Financial Development Program in Ukraine, it is planned to improve the systems of regulation and supervision of the financial sector, continue the transition from compliance based supervision to risk-based supervision and oversight, preventive monitoring (from April 1, 2015 to December 31, 2016), as well as the introduction of new capital requirements for banks in accordance with the principles of Basel III and EU requirements (from January 1, 2015 to December 31, 2019).

These measures are possible only by complying with the requirements of the European Parliament and the Council of Europe, which aim to create a level playing field in the financial sector, strengthen the solvency and liquidity requirements of financial sector participants, introduce special requirements for capital, liquidity and other financial institutions, as well as improving the system of regulation and supervision of the financial sector. According to international principles, an effective banking supervision system must have specific responsibilities and goals, operational independence, transparency, reliability, and resource base. Therefore, the implementation of these principles in the work of the national banking system is extremely important. Currently, the analysis of the current state of the banking sector and the main regulatory aspects indicates the presence of problems that indicate a crisis in the banking system of Ukraine, in particular, in the system of banking regulation and supervision. Thus, according to the regulatory framework, banking supervision in the system of the National Bank of Ukraine has a sufficient level of independence, but during the financial crisis, problematic issues regarding its functional and institutional components were identified.

The National Bank of Ukraine should put in place a methodology for assessing the level of corruption in banking institutions as part of protecting

the bank's economic security. According to Art. 55 of the Law of Ukraine "On the National Bank of Ukraine" the main purpose of banking regulation is defined as security and financial stability of the banking system. Protecting the interests of depositors and creditors. The security system must be constantly changed to take into account all risks. The NBU is no exception. Its oversight system must also be constantly changed and updated. In order to perform its functions, the National Bank of Ukraine has the right to receive free of charge from banks, banking associations and legal entities licensed by the National Bank of Ukraine, as well as from persons in respect of which the National Bank of Ukraine supervises in accordance with the Law of Ukraine banking activities", information about their activities and explanations regarding the information received and transactions. The main difference of the proposed approach is that the author proposes to exercise control not only at the level of control over the economic standards of the bank, but also at the level of building a bank management system. This should include: control over the organizational structure of the bank; increase control over the appointment of bank officials (not only at the level of goodwill, but also at the level of determining the bank's family ties; verification of the bank's economic security system, depending on the type of bank, its activities, volume of operations, number of branches, etc. Table 1 shows the stages of creating a security model for a banking institution. Monitoring the frequency and occurrence of incidents of corruption risk – allows for ongoing control, monitoring, supervision of corruption risks, events related to their implementation directly in the course of operational work. Monitoring involves continuous, systematic and consistent monitoring and prevention of corruption risks. Corruption risk is monitored both at the level of structural units and in the bank as a whole. Ongoing risk monitoring is the internal operational ongoing control and risks that are inherent in the activities of the unit that performs operational monitoring. Continuous monitoring facilitates the prompt detection and implementation of measures to minimize the consequences of corruption risks.

The National Bank should tighten control over the distribution of powers within a commercial bank, the presence of conflicts of interest among bank officials, the construction of critical business processes of the bank, identifying areas where corruption risks are possible. At the legislative level, the NBU needs to consolidate and strengthen control

over the work of the following departments in the Bank and control the distribution of functions and powers of collegial bodies and departments of the Bank, which ensure the economic security of the bank and participate in corruption risk management.

References:

1. Vdovenko L. O., Dumbrovskyy V. A. (2018). Trends in the development of the banking system in the context of the financial crisis. *Modern Economics*, no. 8, pp. 37–45.
2. Hanzhyuk S. M. (2016). Features of the functioning of troubled banks in Ukraine. *Young scientist*, no. 8(35), pp. 11–14.
3. Hetman V. P., Kylymnyk YU. V. (1997). Bank in the system of government. Conversations on the Constitution. Kyiv.
4. Hoyvanyuk M. P. (2008). Regulation of banking: theoretical aspects and features of implementation in Ukraine. *Finance, Accounting and Auditing: Coll. Science. work*. Kyiv: KNEU, no. 11, pp. 13–20.
5. Holovko A. T., Hrushko V. I., Denysenko M. P. (2004). The system of banking supervision, management: textbook. pos. Kyiv: INKOS company.
6. Zavalnyuk T. I., Aleskerova Yu. V. (2021). Financial aspects of banking regulation in Ukraine. Financial mechanisms of sustainable development of Ukraine in the conditions of modern challenges: abstracts of reports of the III International scientific-practical conference of young scientists (Kyiv, NULES of Ukraine, March 18, 2021). Kyiv: KC “COMPRINT”.
7. Zavalnyuk T. I., Aleskerova Yu. V. (2020). Regulatory and legal regulation of the banking system of Ukraine. Conceptual principles of development of the agricultural sector of Ukraine’s economy in the context of global challenges: abstracts of the 74th scientific-practical student conference (Kyiv, November 19, 2020), NULES of Ukraine.
8. Law of Ukraine “On Banks and Banking Activity” of December 7, 2000 № 2121-III. Retrieved from: <http://zakon.rada.gov.ua>
9. Law of Ukraine “On Banks and Banking”. With changes from 13.04.2012. Information of the Verkhovna Rada. 2013. No 21. 208 p.
10. Law of Ukraine “On the National Bank of Ukraine” of May 20, 1999 № 679–XIV. Retrieved from: <http://zakon2.rada.gov.ua/laws/show/679-14>
11. Zinchenko V. I. (2006). Organization of effective banking supervision in Ukraine. *Bulletin of the Ukrainian Academy of Banking*, no. 2, pp. 67–73.
12. Zotko O. Yu., Aleskerova Yu. V. (2020). Budget planning. Conceptual principles of development of the agricultural sector of Ukraine’s economy in the context of global challenges: abstracts of the 74th scientific-practical student conference (Kyiv, November 19, 2020), NULES of Ukraine.
13. Zotko O. Yu., Aleskerova Yu. V. (2021). Financial planning and forecasting of banking activities. Financial mechanisms of sustainable development of Ukraine in the conditions of modern challenges: abstracts of reports of the III International

scientific-practical conference of young scientists (Kyiv, NULES of Ukraine, March 18, 2021). Kyiv: KC “COMPRINT”.

14. Ruda O. L. (2020). The essence, problems and mechanism of financial security of the state. *The scientific heritage*, no. 46, vol. 8, pp. 75–82.

15. Turchak S. H., Aleskerova Yu. V. (2020). Banking system in the economic development of Ukraine. Conceptual principles of development of the agricultural sector of Ukraine’s economy in the context of global challenges: abstracts of the 74th scientific-practical student conference (Kyiv, November 19, 2020), NULES of Ukraine.

16. Turchak S. H., Aleskerova Yu. V. (2021). The place and role of the banking system in the economic development of the state. Financial mechanisms of sustainable development of Ukraine in the conditions of modern challenges: abstracts of reports of the III International scientific-practical conference of young scientists (Kyiv, NULES of Ukraine, March 18, 2021). Kyiv: KC “COMPRINT”.

**ECOLOGIZATION OF AGRICULTURAL PRODUCTION
BASED ON THE USE OF WASTE-FREE TECHNOLOGIES
TO ENSURE ENERGY AUTONOMY OF AIC**

Valeriia Vovk¹

Anastasiia Krasnoselska²

DOI: <https://doi.org/10.30525/978-9934-26-193-0-2>

Abstract. Global climate change due to the greenhouse effect has become a major international and political issue. Carbon dioxide is recognized as one of the main factors enhancing the greenhouse effect. Other known greenhouse gases together account for about half of global warming. Excess in the atmosphere of greenhouse gases and aerosols, solar radiation and the properties of the earth's surface change the energy balance of the climate system. Agriculture is a significant source of greenhouse gas emissions, as livestock and crop production are associated with emissions of carbon dioxide, methane and nitrous oxide. According to reports of emissions that governments regularly submit to the Secretariat of the United Nations Framework Convention on Climate Change, agriculture accounts for about 15% of global greenhouse gas emissions. On the other hand, greenhouse gases change the climate and thus affect agricultural production. At the same time, the share of agriculture in world GDP is about 4%, which indicates that the carbon intensity of agriculture (emissions per unit of output) is quite large. Urgency of ecologization of agriculture of Ukraine is conditioned by worsening of the ecological state of the natural resources, related to the agricultural production, decline of fertility of soils and product quality, by the increase of complex ecologically-destructive influence on the environment. Ecological agriculture is economically advantageous direction of activity with the high level of profitability comparatively with traditional technologies of production. The main direction of agricultural development should be the ecologization of all production processes,

¹ Postgraduate Student, Researcher on Scientific Topics,
Vinnytsia National Agrarian University, Ukraine

² Postgraduate Student, Head of the Personnel Department,
Vinnytsia National Agrarian University, Ukraine

which led to the interest and conduct of this study. *Purpose.* The purpose of the research is to substantiate the theoretical and applied principles of ecologization of agricultural production based on the use of waste-free technologies to ensure energy autonomy of agriculture. The subject of the research is theoretical-methodical and practical aspects of using waste-free technologies for ecologization of agricultural production and ensuring energy autonomy of AIC. *Methodology.* The research used the following scientific methods: monographic (in studying the theoretical provisions of ecologization of agricultural production and use of waste-free technologies), statistical (in analyzing the state of agriculture and the use of waste-free technologies for renewable energy, reducing fossil fuel consumption and how consequence, ecologization of agricultural production) computational and constructive (in substantiating the management practice of resource conservation in agricultural development on the principles of waste-free production), various methods of economic and statistical method (statistical observation, comparison, tabular, graphical) – in the development of visual illustrations; abstract-logical – to summarize research results and formulate research conclusions. *Practical implications.* The impact of biogas production from livestock waste in Ukraine on the ecologization of AIC is analyzed. Measures have been proposed to promote the development of waste-free biogas technologies in Ukraine to ensure energy autonomy of the agro-industrial complex. *Value/originality.* The economic efficiency of replacing natural gas with biogas formed from agrobiomass is determined. The author's bioenergy model of biogas production from agricultural waste is proposed. The analysis of the advantages of biogas production from agrobiomass for ecologization of agricultural production was further developed. The enterprises of Vinnytsia region, which have the largest capacities of biogas production from agrobiomass, are characterized. The study is based on the tasks of applied research on the topic: "Development of scientific and technical support for energy autonomy of the agro-industrial complex based on environmentally efficient use of agrobiomass for biofuel production", state registration number 0122U000844.

1. Introduction

Today, the development of the world economy has been accompanied by numerous negative phenomena, among which the key one was

environmental problems in agriculture, related to irrational use of nature, degradation and pollution of land, water and air, biodiversity loss and more. The answer to the above challenges was the development of the concept of sustainable development, which is based on the harmonization of three main areas – economic, social and environmental.

The main idea of the concept of sustainable development is to preserve the environment and natural resources for future generations, which should be implemented not through traditional methods of environmental protection, but through changes in the model of civilizational development. It aims to reduce the anthropogenic load on the environment in such a way that the pressure on it is not higher than its potential and reproductive capacity. Therefore, the desire for economic growth was replaced by the desire to promote socio-economic development of society while preserving the natural foundations of life.

The intensification of agricultural production in many countries around the world has led to significant negative and even crisis phenomena that have affected almost all forms of living organisms. Excessive chemicalization of agricultural production processes, unlimited use of mineral fertilizers, active use of GMOs in crop and livestock production and other abuses aimed at maximizing profits have led to significant harmful effects on the natural resources and the environment. Society has a crucial task – not only to reduce the negative impact of intensive agricultural practices on human health and the environment, but also to develop and implement innovative agricultural practices that would ensure the balanced development of agriculture, society and nature in general.

That is why in the concept of sustainable development the decisive role is given to the ecologization of agricultural production, which provides a harmonious combination of the created environment of human life and maintaining the quality of the environment, both for present and future generations.

The urgency of ecologization of agricultural production is due to the sharp deterioration of the ecological state of natural resources associated with agricultural production, reducing soil fertility and quality of agricultural products, increasing the complex ecological and destructive impact on the environment. Organic food has a positive effect on the environment and human health. Secondly, as international experience shows, organic

agriculture is a cost-effective area of activity with a higher level of income than traditional production.

2. Analysis of recent research and publications

The idea of ecologization of agriculture is studied by such economists as A. Andreichenko, O. Bondar, A. Burliai, I. Honcharuk, T. Yemchyk (Honcharuk), G. Kaletnik, I. Kyrylenko, N. Pryshlyak, D. Tokarchuk, O. Khodakivska, O. Shkuratov, O. Shpykulyak, O. Shpychak and others.

Concerning ecologization of agriculture Burlyay A. means a managed process of consistent implementation of technical, technological, economic, managerial, organizational, innovative and other measures to form a sustainable socio-ecological-production system in the process of agricultural activities and agricultural production that promote environmental management, conservation and improving the quality of the environment at the local, regional or global levels [4, p. 45].

Honcharuk I. notes that the ecologization of agricultural production should be understood as the gradual spread of environmental priorities in production activities, increasing environmental education and awareness of management, the gradual penetration of environmental innovations in production, environmental modernization of production [5].

Khodakivska O. noted quite rightly that ecologization of agricultural production is a system of national, sectoral and regional measures aimed at introducing into agricultural production of qualitatively new, environmentally friendly types of equipment, technologies and organization of material production, methods and techniques of agricultural and agro-industrial complexes for rational use of natural resources, their preservation, reproduction and maintenance of dynamic ecological balance in the environment, production of safe food for human health and harmonization of relations in the system “man – society – nature” [6].

Tereshchenko V. believe that the ecologization of agricultural production is a purposeful process of introduction of ecological and economic management methods in agricultural practice in order to ensure ecological balance in the natural environment, preservation of landscape and biological diversity, reproduction of natural resources and guarantees of production of environmentally friendly products and raw materials [8, p. 78].

3. Assessment of ecological and destructive impact of agriculture on the environment

The main factors of ecological and destructive impact of agriculture on the environment are soil, water, air and biodiversity. In Ukraine, about 72% of land resources have been mastered at the permissible norm of 60-65% of the total area, plowing reaches 58% at the norm of 40%; agriculture accounts for more than 10% of greenhouse gas emissions from human activities; almost all surface and a significant part of groundwater resources, especially in areas of powerful agricultural complexes, are experiencing anthropogenic impact, manifested in pollution, depletion and degradation of these facilities; the problem of biodiversity loss is growing rapidly [2, p. 58].

Organic waste and waste with high content of organic matter in unorganized discharges and spontaneous storage are the most dangerous to the environment. The main factor of their negative impact is the processes of decay and other biochemical transformations, which are accompanied by intensive accumulation and migration into adjacent environments of very toxic, often well-soluble organic products.

The structure of total greenhouse gas emissions from the agricultural sector of Ukraine in 2019 is shown in Figure 1.

The peculiarity of the threatening situation in the field of agricultural waste management in Ukraine is the large volume of their formation in the absence of proper infrastructure for their management and environmentally friendly technologies for the use of waste as raw material. The most hazardous agricultural wastes are livestock wastes, which account for 9% of global CO₂ emissions, 35-40% of global methane emissions, and 64% of global nitrous oxide emissions. According to the National Inventory of Anthropogenic Greenhouse Gas Emissions [10], the second largest producer of greenhouse gases in Ukraine animal excrement: pig-breeding – 46.0%, livestock – 30.0%, poultry – 20.0%, other animal species account for 4% of emissions. Therefore, the problem of environmental challenges in the livestock sector is considered from the standpoint of reducing the negative impact of the industry on the environment, and globalization and the pace of climate change require new approaches to addressing the disposal and recycling of livestock waste.

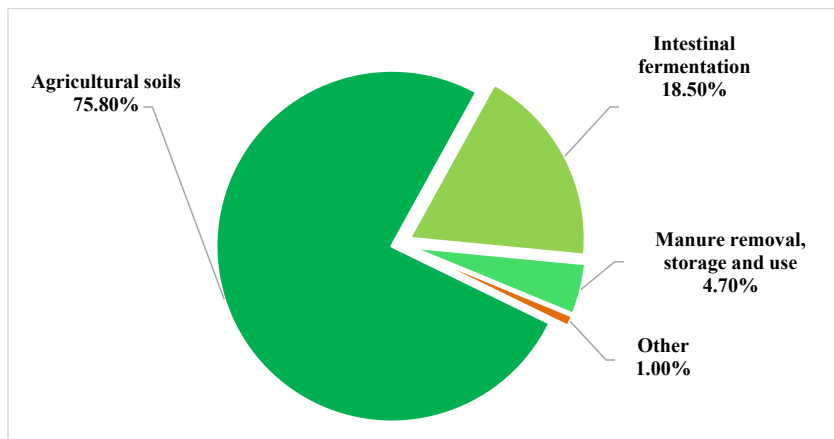

Figure 1. Structure of total greenhouse gas emissions from the agricultural sector of Ukraine in 2019, %

Source: formed by the authors according to the data [9, p. 152]

Drains from livestock complexes are doubly dangerous because they cause both chemical and biological contamination (by microorganisms). Moreover, they pollute the soil directly, as well as water and air. Up to 605 kg of dust, 14.4 kg of ammonia and 83.4 billion microorganisms enter the air from one pig farm for 10-40 thousand animals in 1 hour.

The livestock industry in Ukraine is declining every year, which has a positive effect on reducing greenhouse gas emissions, but at the same time leads to a significant reduction in humus stocks in soils and weakening the crop industry. According to the Institute of Soil Protection of Ukraine, a century ago Ukrainian soil contained an average of 4-6% humus, and now – 3.2%. If less than 2.5% of humus remains in the soil, it will no longer be chernozem (black earth). Every 5 years the soils of Ukraine lose on average 0.05% of humus. In monetary terms, over twenty years it amounted to about UAH 450 billion, and annually it is more than UAH 20 billion. In 2021, the number of cattle in Ukraine was 2.87 million; 5.88 million pigs and 200.7 million poultry. Every year the livestock industry in Ukraine is declining, as evidenced by the data in table. 1.

Table 1
Formation of livestock by-products (pus, droppings) in Ukraine, 2017–2020

Type of raw material	Yield of manure or manure, t / animal place / year	Years									
		2017		2018		2019		2020		2021	
		million heads	amount of waste, million tons	million heads	amount of waste, million tons	million heads	amount of waste, million tons	million heads	amount of waste, million tons	million heads	amount of waste, million tons
Cattle manure	18,00	3.68	66.4	3.53	63.54	3.33	59.94	3.10	55.80	2.87	51.66
Pig manure	3,60	6.67	24.01	6.11	22.00	6.03	21.71	5.73	20.63	5.88	21.18
Bird droppings	7.50 / 100	201.7	15.13	204.8	15.36	211.7	15.88	220.5	16.54	200.7	15.05

Source: formed by the authors on the basis of data [11] and own calculations

Comprehensively solve the problem of environmental pollution by methane and nitrogen emissions from livestock waste possible through the introduction of innovative environmentally friendly technologies for the disposal of agricultural waste, including biogas plants. Such installations are widely used in European agricultural and industrial enterprises.

4. The use of waste-free technologies in agricultural production to ensure energy autonomy of agriculture

The introduction of waste-free technologies in agricultural enterprises and the production of biofuels such as biodiesel, bioethanol and biogas are one of the alternatives to traditional fuels in agriculture. The production of biofuels contributes not only to the energy autonomy of the agro-industrial complex, but also to the reduction of a number of environmental threats.

In our opinion, the most promising area of waste-free technologies of agricultural production is the production of biogas from agricultural waste. Due to the rapidly growing

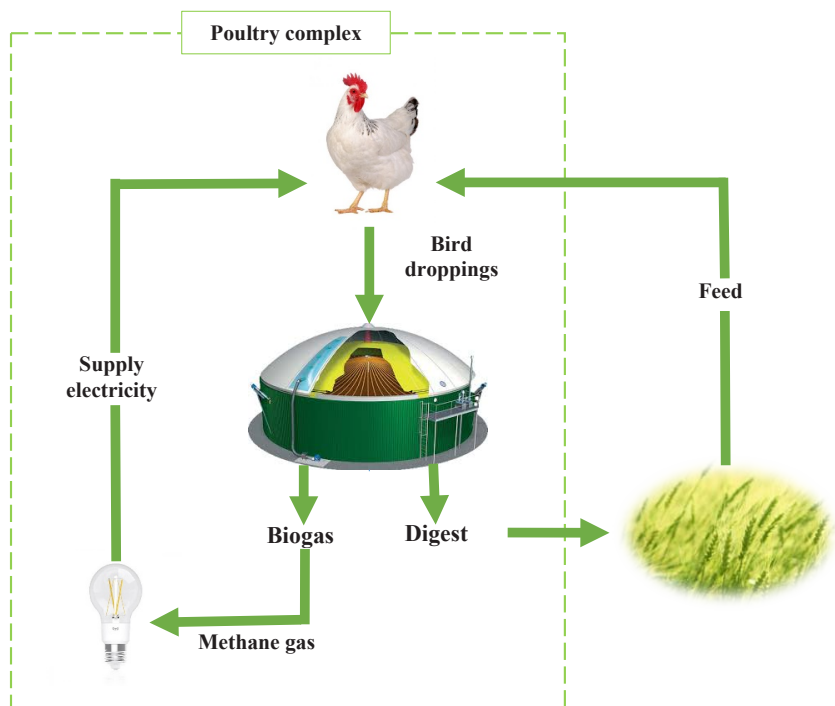

Figure 2. Advantages of introduction of waste-free technologies for utilization of agricultural waste (on an example of a poultry complex)

Source: created by the authors

amount of organic waste, biogas production solves the problem of waste disposal, thereby preventing emissions of methane and other greenhouse gases into the environment, reduces the use of chemical fertilizers and prevents contamination of soil and subsoil water.

In Figure 2 the author's vision of the advantages of the process of biogas production from agricultural waste on the example of the functioning of the poultry complex and biogas production from bird droppings is given.

The common practice of storing industrial waste (manure) in open pits or lagoons leads to environmental degradation in the surrounding areas. Disposal of manure in large quantities is expensive, and fines for violating sanitary norms are also large. Obtaining biogas from manure not only solves

this problem, but at the same time is a way to generate additional income from the sale of heat and electricity. To ensure stable and uninterrupted operation of the biogas plant, it is better to provide for the possibility of biogas production from mixed raw materials – crop and livestock waste. Thus, a biogas plant running on agricultural waste will be evenly loaded throughout the year, and biogas production will be a manageable and predictable process.

In addition, the use of waste-free technologies in agricultural production will not only reduce the ecologically destructive impact on the environment, but also change the structure of final energy consumption in favor of renewable energy sources and ensure energy autonomy of agriculture. According to the State Statistics Service of Ukraine, in 2020 the largest share in the structure of energy consumption of Ukraine's agro-industrial complex is occupied by oil products (1060 thousand tons AD), electricity (325 thousand tons AD), heat (174 thousand tons AD) and natural gas (122 thousand tons AD). Consumption of energy produced from coal and peat (5 thousand tons AD) and biofuels and waste (28 thousand tons AD) is a small share (Table 2) [11].

Biogas derived from biomass is used as a fuel and is not harmful to the environment, as it does not cause additional greenhouse gas emissions and reduces the amount of organic waste. Unlike wind energy and solar radiation, biogas can be produced regardless of climatic and weather conditions. Unlike fossil energy sources, biogas in Ukraine has a renewable potential of 3.2 billion m³, which remains unused [12].

Due to the fact that the energy value of different agricultural wastes is not the same, the output of gas from 1 ton of it also differs. Manure from livestock complexes is mainly used to produce biogas. It is known that 1 goal. cattle on average per day gives 45 kg of manure, from which you can produce 2.5 m³ of biogas, the output of manure and gas from 1 goal. pigs – 6.5 kg and 0.3 m³, respectively, poultry – 0.137 kg and 0.02 m³. At the same time, its cost is 15-20 euros per 1000 m³.

In Figure 3 shows the volume of biogas production using a variety of raw materials. When choosing biogas plants, keep in mind that they can be applied simultaneously to different raw materials and use different methods depending on the moisture content. At the same time, special enzymes are used to increase the efficiency of biogas production and reduce equipment recovery time.

**Final energy consumption of the agro-industrial complex
of Ukraine for 2017–2020**

№	Types of fuel and energy	Years							
		2017		2018		2019		2020	
		тис. т.н.е	%	тис. т.н.е	%	тис. т.н.е	%	тис. т.н.е	%
1	Coal and peat	7	0.38	7	0.37	7	0.37	5	0.30
2	Crude oil	-	-	-	-	-	-	-	-
3	Petroleum products	1152	62.37	1190	62.40	1244	66.24	1016	60.51
4	Natural gas	131	7.09	122	6.40	96	5.11	122	7.27
5	Atomic energy	-	-	-	-	-	-	-	-
6	Hydroelectricity	-	-	-	-	-	-	-	-
7	Wind, solar energy, etc.	-	-	-	-	-	-	-	-
8	Biofuels and waste	25	1.35	37	1.94	28	1.49	28	2.26
9	Electricity	313	16.95	333	17.46	316	16.83	325	19.36
10	Heat energy	218	11.80	219	11.48	188	10.01	174	10.36
11	Total	1847	100.0	1907	100.0	1878	100.0	1669	100.0

Source: formed by the authors according to the State Statistics Service of Ukraine [11]

Note. 2017–2020 without taking into account the temporarily occupied territory of the Autonomous Republic of Crimea and the city of Sevastopol and part of the temporarily occupied territories in Donetsk and Luhansk regions.

Thus, Ukraine has a well-developed agriculture, the waste from which provides an excellent raw material base. According to the State Agency for Energy Efficiency and Energy Saving, the use of only 37% of waste from livestock and crop production will produce more than 10 billion m³ of gas. Table 3 lists potential substrates (agricultural waste) for biogas production.

Given the above, it can be concluded that the existing potential of biogas production from organic agricultural waste in Ukraine and the significant benefits of using biogas technologies for energy generation create favorable conditions for the development of the domestic agrobiogas sector. According to the Bioenergy Association of Ukraine, the average electricity production from biogas in 2020 was about 36.0 million kWh. Capital cost savings when using biogas plants in enterprises is 30-40%.

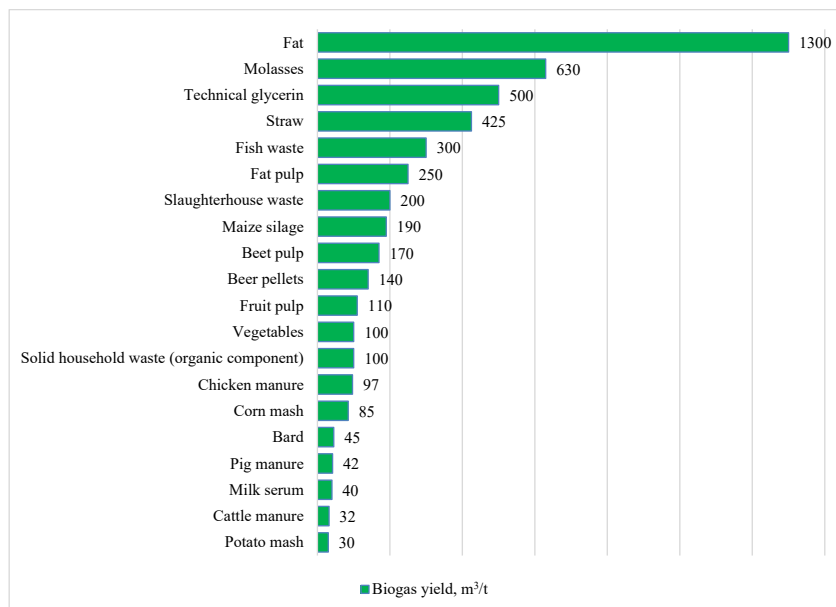

Figure 3. Biogas yield from 1 ton of substrate

Source: generalized by the authors on the basis of processed literature sources

The chemical composition of biogas produced in biogas reactors is close to natural, without its purification (natural: methane (CH₄) – 80-90%, carbon dioxide – up to 10%, biogas: methane (CH₄) – 65-70%, carbon dioxide – up to 30%) In terms of heat of combustion 1 m³ of biogas is equivalent to: 0.8 m³ of natural gas, 0.7 kg of fuel oil, 0.6 kg of gasoline, 0.85 liters of alcohol, 1.6 kg of firewood, 1.4 kW. The total calorific value of biogas is from 5,000 to 8,000 kcal/m³. So biogas can be used as natural gas: to accumulate, pump, generate electricity, use as fuel for internal combustion engines [6].

Equating the selling price of biogas to the cost of natural gas (UAH 9.9 thousand per 1000 m³), the gross profit from biogas production for agricultural formations of Ukraine can range from 5.08 to 24.86 million UAH. depending on the type of raw material. For the company, the advantages of implementing a biogas plant are cost savings through the

Biogas output potential from agricultural waste

Substrate	Dry matter (SR), %	Dry organic matter (COP), %	Specific yield of biogas, m ³ /t COP	Specific yield of biogas, m ³ /t
Crop by-products				
Corn silage	32.0	95.0	700.0	212.8
Straw	30.0	90.0	600.0	162.0
Grass silage	30.0	89.0	550.0	1416.9
Sugar beets	23.0	90.0	800.0	165.6
Mangold	12.0	75.0	620.0	55.8
Oilcake	28.0	94.0	680.0	179.0
Livestock by-products				
Pig manure	3.0	85.0	425.0	10.8
Cattle manure	25.0	80.0	350.0	70.0
Bird droppings	24.0	85.0	425.0	86.7

Source: formed by the authors on the basis of data from the Bioenergy Association of Ukraine [4]

production of electricity and heat from its own raw materials, reducing dependence on external energy sources, the ability to provide energy to other consumers. From 1 m³ of biogas it is possible to produce about 2-2.5 kWh of electricity and up to 2.5-3 kWh of heat energy by cooling the engines after burning biogas to produce electricity. However, the economic benefits of using biogas in each case will depend on the type of waste available for processing, investment opportunities, the availability of the local energy market and government initiatives [14, p. 196].

For agricultural enterprises, the advantages of implementing environmentally friendly waste-free technologies for biogas production from waste are cost savings through the production of electricity and heat from their own raw materials, reducing dependence on external energy, the ability to provide energy to other consumers. However, the economic benefits of using biogas in each case will depend on the type of waste available for recycling, investment opportunities, the availability of a local energy market and government initiatives. For example, in European practice, farmer's biogas plants are common, usually owned by a single farmer, and centralized biogas plants, which have more capacity and are

usually cooperative property (owned by several farmers) and are considered more cost-effective. scale effect). When planning, first all available resources are identified and the possibilities of their use in different scenarios are calculated, after which a decision is made on the location, type of installation, capacity and load. In the countries of the European Union, the payback period of biogas plants for processing waste from the agro-industrial complex averages 6-14 years, or taking into account the green tariff for the sale of electricity to the grid – 4-8 years [14, p. 198].

The mechanism of biogas production from agricultural waste at agricultural enterprises to ensure energy security is presented in Figure 4.

Thus, the bioenergy model of biogas production from agricultural waste provides a significant environmental effect:

– at the local level the problem of pollution of both groundwater and water basins in general by pathogens and chemicals is solved; there is an improvement in the quality of drinking water directly near livestock farms or poultry farms; the unpleasant smell disappears near the objects of the livestock industry;

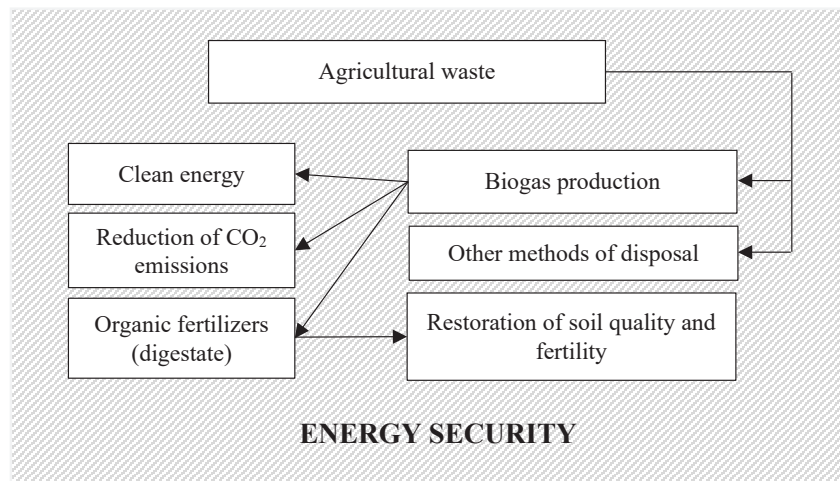

Figure 4. Bioenergy model of biogas production from agricultural waste

Source: developed by the authors

– with the use of biofertilizers obtained from the production of biogas, the problem of increasing soil fertility and preventing their degradation is solved; reduces weeds, acidity, salinity of soils; Organic organic food is obtained, which has a positive effect on the health of the population;

– at the global level, there is a reduction in greenhouse gas emissions, which contributes to the implementation of state environmental commitments.

In Vinnytsia region there are two powerful enterprises for the production of biogas from livestock waste – LLC “Vinnytsia Poultry Farm”, and biogas from crop waste – LLC “Yuzefo-Mykolayiv Biogas Company”. The region is not only a leader in the production of gross agricultural output, but also can become one of the leaders in the implementation of waste-free technologies that provide a full cycle of recycling economy.

Another striking example of the efficient use of recycled waste from its own production is a young agricultural enterprise in the Vinnytsia region – Organic-D LLC, which operates on the principle of waste-free production, using its own biogas plant.

The algorithm of this station is as follows – the remains of animals from the premises are merged into a biogas plant and fermented for 30 days. As a result of the biogas plant, the company receives:

- biogas output (1200 m³/day);
- volume of electricity (250-300 kW) and heat energy (300-350 kW);
- organic fertilizer digestate (60 t/day), which enriches its own agricultural land [15, p. 518].

The introduction of biogas plants on agricultural enterprises will allow to establish an environmentally friendly, waste-free method of processing, disposal and disinfection of various organic wastes of plant and animal origin. On the other hand – such installations become a source of additional income, reduce costs and cost of production by providing energy and organic fertilizers of the main production of enterprises. When using a biogas plant, the actual energy consumption is 20% of the received. In the case of using biogas for the simultaneous production of electricity and heat (cogeneration), 30-40% of energy is converted into electricity, 40-50% – in heat, the rest is sent to their own needs.

Thus, agriculture, in particular livestock, can make an important contribution to combating climate change by moving to a circular economy,

sustainable production through the introduction of environmentally friendly resource-saving technologies for processing crop residues and animal manure into biofuels. Utilization of agricultural waste, namely livestock waste by processing it into biogas, is an important aspect not only of environmental friendliness of this process, but also contains an energy component – energy security, ie use of renewable raw materials and abandonment of fossil fuels or imports, energy diversification. However, the economic benefits of using biogas in each case will depend on the type of waste available for recycling, investment opportunities, the availability of a local energy market and government initiatives.

5. Development of waste-free biogas technologies in the world

Currently, more than 65 countries around the world use biogas plants to produce biogas as an alternative energy source. China is the leader in the use of biogas technologies, with more than 15 million biogas plants. 86% of China's alternative sources are made from agricultural waste and only 14% from industrial and sewage waste. China has a medium- and long-term plan for the development of renewable energy in order to achieve an annual level of biogas production of 50 billion m³, which should be provided by both industrial-type biogas plants and low-power home stations. In India, there are about 10 million biogas plants [16, p. 806].

As of the end of 2019, there were 18,838 biogas plants in operation in Europe (this figure increased by 4% compared to 2018 and by 69% compared to 2009) (Figure 5). Currently, the EU biogas sector produces 15.8 billion cubic meters of biogas and 2.43 billion cubic meters of biomethane, with 75% of biogas produced from agricultural waste, 17% from organic waste from private households and businesses and another 8% from sewage treatment plants [17].

Today, the leader in biogas production in Europe is Germany, where there are about 11,000 biogas plants (about half of all global plants), but only 7% of biogas produced by enterprises goes to gas pipelines, the rest is used for the needs of producers. Germany produces 93% of biogas through fermentation of crops and crop residues. In the future, with the optimal use of biogas in Germany, electricity from this type of fuel will be able to provide 12 million households. Already, electricity and heat produced from biogas are enough for about 500,000 private homes and apartments.

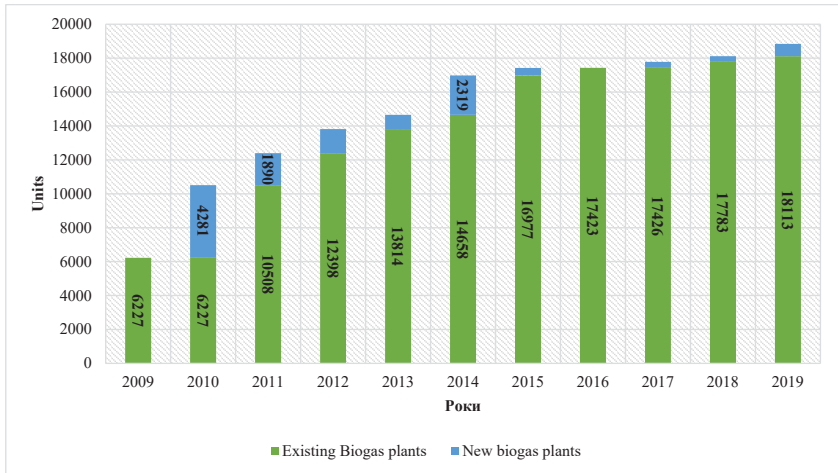

Figure 5. Dynamics of increasing the number of biogas plants in Europe, 2009–2019

Source: based on data from the European Biogas Association [18]

As the German Federal Law on Renewable Energy creates favorable conditions for the use of biomass, it is natural that three of the six largest European companies in the biogas industry are German: Strabag Umwelтанlagen GmbH, Schmack Biogas AG, Biotechnische Abfallverwertung – with a total of 280 plants and 280 production of about 3.7 million tons [14, p. 194–195].

According to the European Biogas Association, the leaders in the number of biogas plants, in addition to Germany, are Italy – 1491, Great Britain – 813, France – 736, Switzerland – 633, Czech Republic – 554, Austria – 436 plants [18].

Among the European countries with a high rate of development of biogas technologies that work on agricultural waste can be identified, as already mentioned, Germany, as well as Italy, France and the Czech Republic; for solid waste – Great Britain, Spain, Italy and France; from wastewater effluents – Sweden, Lithuania, Poland [19, p. 106–107].

In the United States, despite the large number of farms, the biogas market is developing at a much slower pace than the European one. There are about

2,100 biogas plants in the country, which mainly operate on agricultural waste, including livestock waste (cattle manure). The total capacity of all plants on such farms is approaching 60 MW. The US biogas plant market is estimated at \$ 2.4 billion in 2020. Most American biogas plants are concentrated in New York, Pennsylvania, Vermont and Wisconsin. However, they cover only a small part of the 8,000 farms where biogas production could be introduced. Thus, according to American experts, on average, a herd of 1,000 cows can provide fuel for about 250 kW of generating capacity, so the potential of all US farms to generate energy from biogas reaches 1,600 MW [20].

According to experts from the European Biogas Association, the next ten years will see rapid growth in the biogas and biomethane sectors, and in the future the share of biomethane in European gas production will be 33-40%. At the same time, members of the European Biogas Association believe that the potential for biogas and biomethane production in Ukraine is quite high. Not surprisingly, in 2019 Ukraine ranked 8th among the 100 developing

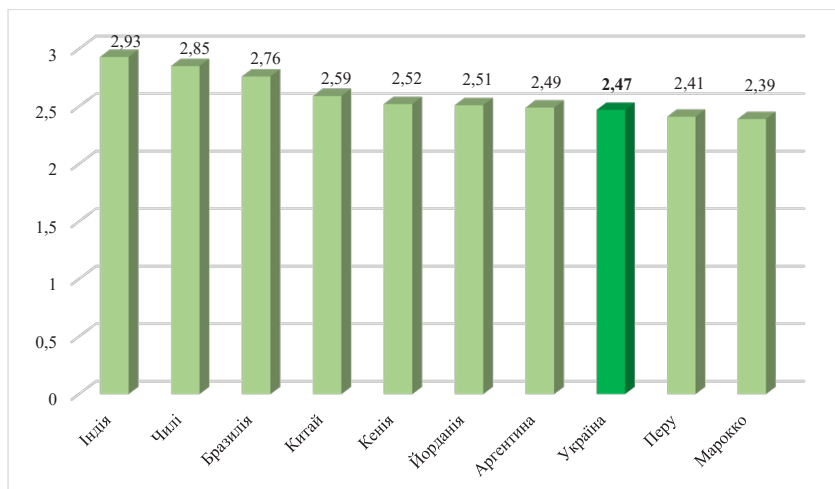

Figure 6. Estimation of attractiveness of investments in renewable energy sources among developing countries in 2019

Source: based on the annual Climatescope report [21]

countries in terms of attractiveness of investment in renewable energy sources (RES) [10], which is 55 places higher than in 2018 (Figure 6).

Investing in biogas plants for large agricultural enterprises solves several problems. One of the most important is the processing of waste, which is especially relevant for livestock complexes. The cost of burying manure that pollutes the environment and harms the environment is in the hundreds of thousands. It is wiser to spend this money on the construction of a biogas plant. The resulting biogas will be used as fuel for the heating system, or will be used for other purposes.

The task of introducing waste-free technologies in agro-industrial production is extremely important in today's conditions and is to create closed production cycles with recycling of raw materials, when each end of one production serves as a starting point of the next, resulting in no waste and minimizes negative consequences. natural environment. That is why it is so important to intensify research and innovative developments to create new waste-free technologies for agricultural production.

The high initial cost of investment and a fairly long payback period (4-8 years) of biogas plants contribute to the reduction of the number of actual and potential investors in RES. One of the solutions to this problem is the creation of an energy cooperative – a voluntary association of individuals and / or legal entities on a share basis to conduct joint economic activities in the field of energy efficiency or RES [22].

Germany and Austria are among the leading countries in the establishment of energy cooperatives. For example, in Germany in 2019, 14 energy cooperatives were established. These include six local heating cooperatives and two energy cooperatives, each specializing in photovoltaics and wind energy. The business models of other new energy cooperatives are very different.

According to the Federal Office for Energy Cooperatives, there are a total of 843 energy cooperatives in Germany by the end of 2020, bringing together 200,000 people. They invested a total of 2.9 billion euros in renewable energy and generated about 8.31 TWh of clean electricity in 2019. This avoided 3.39 million tons of CO₂ emissions [23].

Another example of the creation of energy cooperatives is the United Kingdom. Currently, there are a large number of energy cooperatives in this country that specialize in renewable energy sources. There are cooperatives that produce and use solar, wind, hydro and biomass energy.

In the United States, quite a large part of the electricity market is occupied by energy cooperatives, which are formed by communities. In total, there are 903 cooperatives in this country that deal with the distribution (delivery to the final consumer) of electricity. They provide power to 42 million people in 47 states. The service areas of these cooperatives cover 75% of the United States. All these networks, together with all the equipment belonging to them, are in the direct ownership of the members of the respective energy cooperatives [24].

6. Ecologization of soils through the introduction of waste-free technologies of agriculture

Plowing of agricultural land in Ukraine is one of the highest in the world and reaches 78.1%. In 2019–2020, the plowing of agricultural land in some regions of Ukraine reached 80-90% (Vinnytsia – 85.7%, Donetsk – 81.0%, Zaporozhye – 84.8%, Kirovograd – 86.8%, Lugansk – 66.4%, Mykolaiv – 84.5%, Odessa – 79.7%, Ternopil – 81.4%, Kherson – 90.2%, Cherkasy – 87.6%). While the amount of plowed agricultural land in the United States is 38.9%, China – 21.5%, Great Britain – 35.3%, Austria – 47.5%, in the Netherlands the percentage of plowing is 55%. At the same time, in these countries the level of GDP is much higher and the share of agro-industrial complex in GDP is from 1 to 3%, while in Ukraine – more than 12%. This indicates that Ukraine is gradually transforming from an industrial-agrarian country to an agrarian country with clear characteristics of the raw material type [1, p. 230].

The structure of agricultural land in Ukraine in 2020 is shown in Figure 7.

Intensive agricultural land use affects the reduction of soil fertility, as noted by Honcharuk I. [26, p. 27], in connection with their compaction, destruction of structure, permeability and aeration capacity with all environmental consequences. Land degradation and desertification are one of the most serious challenges to the country's sustainable development, causing significant environmental and socio-economic problems.

Due to land degradation during 1986–2020, the humus content decreased by 0.19% and is 3.17%. During this period, the loss of humus in the arable layer was 5500 kg/ha. Every year, with the harvest of agricultural crops, 77-135 kg of nutrients (nitrogen, phosphorus, potassium) are irrevocably alienated from each hectare. To ensure a deficit-free balance of humus in soils and their deoxidation, the urgent task is to change the fertilizer

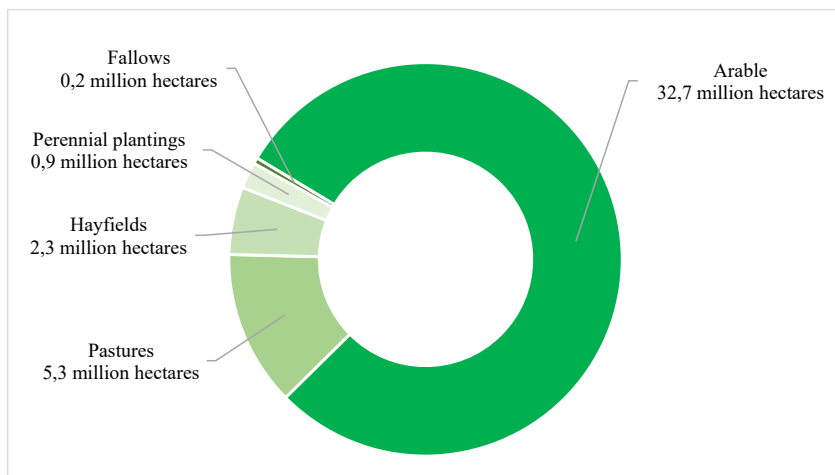

Figure 7. The structure of agricultural land in Ukraine in 2020

Source: formed by the authors on the basis of the Land Directory of Ukraine-2020 [25]

application system with a reorientation to increase the share of organic fertilizers. The amount of organic fertilizers per 1 hectare in 2020 compared to 1990 decreased by 22 times. Decrease in livestock relative to 1990 levels: cattle – 7.5 times, pigs – 3.3 times, goats and sheep – 7 times (Table 4).

To ensure a deficit-free balance of humus in soils and their deoxidation, the urgent task is to change the mineralization system with a reorientation to increase the share of organic fertilizers. One of the ways to solve the problem of soil degradation in Ukraine is to use as an organic fertilizer digestate – a by-product of processing organic matter that remains after biogas production. During the separation of the digestate, solid (sludge) and liquid (concentrate) fractions are formed.

Digestate is liquid and solid. Liquid digestate is added to the soil, and the solid fraction of digestate can be dried, granulated and conveniently combined with other wastes. It is also convenient to combine with other wastes or organic products, such as wood chips, sawdust. Digestate improves the condition of crops by providing additional nutrients and helping to maintain the necessary soil moisture. If mineral fertilizers are absorbed only by 35-50%, then biofertilizers – almost 99% [26, p. 27].

Table 4
The state of maintaining the content of organic matter (humus) in the soils of Ukraine in 1990–2020

Indicator	Years							Deviation 2020/1990, +/-
	1990	2016	2017	2018	2019	2020	2020	
Livestock of cows, million heads	25.2	3.9	3.8	3.7	3.5	3.3	3.3	-21.9
Livestock of pigs, million heads	19.9	7.4	7.1	6.7	6.1	6.0	6.0	-13.9
Livestock sheep and goats, million heads	9.0	1.4	1.3	1.3	1.3	1.3	1.3	-7.7
Poultry, million heads	255.1	213.3	204.0	201.7	204.8	211.7	211.7	-43.4
Volume of applied organic fertilizers, million tons	260.7	9.7	9.2	9.3	11.6	11.4	11.4	-249.3
Application of organic fertilizers per unit area of agricultural land, kg/ha	6207.8	232.8	220.8	223.5	280.7	274.3	274.3	-5933.5
Areas treated with organic fertilizers, million hectares	5.5	0.4	0.5	0.5	0.8	0.8	0.8	-4.7
The total amount of mineral fertilizers applied, million tons N, P ₂ O ₅ i K ₂ O	4.4	1.4	1.7	2.0	2.3	2.3	2.3	-2.1
The amount of mineral fertilizers per unit area of agricultural land, kg N, P ₂ O ₅ i K ₂ O /га	105.1	34.1	41.7	48.9	56.5	56.3	56.3	-48.8
Areas treated with mineral fertilizers, million hectares	26.4	14.5	15.7	16.5	16.1	16.4	16.4	-10.0
Humus content in the soil, %	3.36	3.17	-	-	-	-	-	-

Source: calculated according to the State Statistics Service of Ukraine and the Institute of Soil Science and Agrochemistry

Currently, the total formation of digestate at biogas plants in Ukraine is about 2 million tons and will increase with the number of biogas capacity in Ukraine. Thus, 780 kg of digestate is formed from 1 ton of corn silage, 890 kg from 1 ton of chicken manure, 910 kg from 1 ton of pulp, 920 kg from cattle manure, and 990 kg from pig manure. For every megawatt of biogas plant capacity, 40-50 thousand tons of such digestate are formed per year.

The first experiments with the use of digestate as a fertilizer showed that it has an effect and this effect is even higher than that of more traditional counterparts. For example, in England, digestate (although from food waste) has increased winter grain yields by 10% on average over 3 years, while green compost – by 7%, mixed compost (from green mass and food waste) – by 8%, manure – by 9% and manure with straw – by 10%. In another experiment, the application of 30 m³/ha of digestate, each ton of which contained 3.6 kg of nitrogen, 1.7 kg of P₂O₅ and 4.4 kg of K₂O, saved 108.6 euros/ha of mineral fertilizers [27].

“Myronivsky Khiboproduct”, the company that owns powerful biogas plants in Dnipropetrovsk and Vinnytsia regions, was the first in Ukraine to use digestate from biogas plants as an organic fertilizer. The main raw material of biogas plants is chicken manure. In the Dnipropetrovsk region, small amounts of sorghum silage are added to it, in Ladyzhyn – straw and cattle manure.

The digestate obtained at “Myronivsky Khiboproduct” biogas plants had the following composition:

Liquid fraction: pH – 7.7-9.1. In 1 m³ of total: nitrogen – 6.6 kg, phosphorus – 1.9 kg, potassium – 6.2 kg. Manganese – 21 mg/kg, zinc – 8.2 mg/kg, copper – 14.1 mg/kg, cobalt – 7.2 mg/kg, sulfur in the liquid – 0.27%.

Solid fraction: pH – 7.7-9.3. General: nitrogen – 6.8 kg/t, phosphorus – 3.1 kg/t, potassium – 2.7 kg/t. Manganese – 47.65 mg/kg, zinc – 12.5 mg/kg, copper – 34.5 mg/kg, cobalt – 18.1 mg/kg, sulfur in the liquid – 1.56%.

In Vinnytsia region, the experiment was set up in the fields of winter wheat by a farmer in the village of Vasylivka near Ladyzhyn, not far from the biogas plant. The soil in this area was acidic and low humus (only 1.5%). Two variants of digestate application were tested – in August (barrels for liquid fertilizers) and in March (via hose-drum irrigation machines). In the first section in February, the wheat was thicker and generally better than

in the control. On the second, after some time, it was also noticeable that wheat is greener than in neighboring areas, where the traditional scheme of feeding mineral fertilizers was used [27].

Despite the positive developments, the use of digestate as an organic fertilizer to increase soil fertility is currently not widespread. The main barriers to the use of digestate biogas plants as organic fertilizers in Ukraine are the following:

1. Most biogas projects in Ukraine are based on the concept of an energy company focused on obtaining basic income from the sale of electricity at a “green” tariff – the placement of digestate on the market as an organic fertilizer was not considered.

2. Most biogas plants in Ukraine do not regularly control the quality of raw materials and digestate according to a set of indicators, and technological regimes change throughout the year – the physico-chemical composition of digestate is uncontrolled and unpredictable.

3. Digestate from most biogas plants in Ukraine cannot be considered an organic fertilizer for organic crop production – lack of demand in the segment of the organic production market.

4. Lack of state control over the quality of digestate and its management, as well as the lack of its own system to ensure / standardize the quality of digestate generated by operators of most biogas plants in Ukraine – lack of trust among potential consumers and, consequently, demand.

5. Lack of a system of voluntary certification and quality assurance of digestate (outside the market segment of organic production) – lack of opportunity to create an image of a quality product – lack of trust among potential consumers and, accordingly, demand.

6. The lack of state norms and requirements for the production and use of organic fertilizers in general, and digestate in particular – slows down the creation of a market for organic fertilizers from digestate.

Thus, the digestate of biogas plants can be a valuable resource for maintaining / restoring soil fertility in Ukraine and make a significant contribution to the substitution of imported mineral fertilizers. When using the digestate, it was found that it is universal and suitable for all soils, as well as for feeding all types of plants; increases the content of organic matter (humus); improves water and air regime of soils; it can be made at any time; has neutral acidity and deoxidizes the soil; absence of pathogenic

organisms; allows you to increase yields, as it contains a full range of essential macro-and micronutrients, organic compounds that improve soil structure and humic acids; creates preconditions for the development of organic agricultural production and increase income from sales.

7. Conclusions

Thus, the need for ecologization of agriculture is due to the sharp deterioration of the ecological resources of natural resources associated with agricultural production, reducing soil fertility and quality of agricultural products, significant accumulation of agricultural waste, increasing complex ecological and destructive impact on the environment.

Based on the research, it was determined that an important aspect of ecologization agricultural production is the use of waste-free technologies in enterprises. The problem of waste in the agricultural sector of Ukraine requires the development of a new vision: waste from the agricultural sector should be considered as a source of secondary material and energy resources; it is necessary to minimize the generation of waste from the agricultural sector in the process of production and consumption by efficient methods; it is necessary to ensure maximum processing and utilization of waste from the agricultural sector, implementing the most efficient waste management technologies (waste-free technologies); at each stage of waste generation it is necessary to determine the methods of reuse of natural resources (recycling) and recycling of waste; Waste management of the agricultural sector should begin with planning the rational use of natural resources and production of agricultural products as raw materials for industrial processing, and continue with the design of the entire life cycle of production and consumption of various useful products.

The introduction of waste-free agricultural production into modern economic activity involves the balanced use of nutrients, energy and nature, while ensuring resource efficiency, competitiveness, innovation, increasing employment and welfare and income from agricultural production.

We believe that one of the most promising areas of implementation of waste-free technologies in agricultural enterprises is the processing of crop and livestock waste into biogas – the only type of RES that can be used in several ways. It can be burned in heating installations and receive heat for heating. The introduction of biogas plants on agricultural enterprises

will allow to establish an environmentally friendly, waste-free method of processing, disposal and disinfection of various organic wastes of plant and animal origin. On the other hand – such installations become a source of additional income, reduce costs and cost of production by providing energy and organic fertilizers of the main production of enterprises.

The ecological effect of biogas production is the safe processing of organic waste and by-products of animal origin, due to methane fermentation. In total, we have identified 5 main environmental effects from the introduction of biogas complexes in agricultural enterprises:

- 1) use of crop and livestock waste as secondary raw materials to ensure energy autonomy;
- 2) solving the problem of storage and transportation of raw materials;
- 3) reducing the use of fossil fuels, resource conservation and the introduction of alternative energy sources;
- 4) use of digestate as an organic fertilizer to increase soil fertility;
- 5) reduction of greenhouse gas emissions.

As indirect environmental effects can be identified – to prevent contamination of groundwater and surface water and soil.

Ukraine has great raw material potential for biogas production and significant opportunities to increase the capacity of biogas plants. Processing of organic waste from production and consumption in a biogas plant is an economically and environmentally optimal solution. The products (biogas, biofertilizers) generated as a result of waste disposal help to solve the problem of meeting the needs of certain categories of material resources, namely energy and fertilizers, which will increase production while reducing the use of natural resources. Replacement of energy and fertilizers with biological analogues, which is achieved through the disposal of industrial waste for biogas, as well as a significant reduction in their imports – have a positive impact on the internal balance in the country and its GDP.

References:

1. Honcharuk, I. V. (2020). Zabezpechennia enerhetychnoi nezalezhnosti ahro-promyslovoho kompleksu na zasadakh staloho rozvytku [Ensuring the energy independence of the agro-industrial complex on the basis of sustainable development]. *Doctor's thesis*. Vinnytsia.
2. Hutorov, O. I., & Burliai, A. P. (2021). Naukovo-praktychni pidkhody ta napriamy formuvannia orhanizatsiino-ekonomichnoho zabezpechennia ekolohi-

zatsii silskoho hospodarstva Ukrainy v umovakh staloho rozvytku [Scientific and practical approaches and directions of formation of organizational and economic support of ecologization of agriculture of Ukraine in the conditions of sustainable development]. *Visnyk Kharkivskoho natsionalnoho ahrarnoho universytetu imeni V.V. Dokuchaieva. Seriiia "Ekonomichni nauky"* – *Bulletin of V.V. Dokuchaev Kharkiv National Agrarian University. Series "Economic Sciences"*, 1, 55–69. DOI: <https://doi.org/10.31359/2312-3427-2021-1-55>

3. Kaletnik, H. M., Honcharuk, T. V. (2013). Innovatsiine zabezpechennia rozvytku biopalyvnoi haluzi: svitovy ta vitchyzniani dosvid [Innovative support of biofuel industry development: world and domestic experience]. *Biznes Inform – Business Inform*, 9, 155–160.

4. Burliai, A. P. (2019). Hnoseolohiia poniattia "ekolohizatsiia silskoho hospodarstva" v konteksti staloho rozvytku suspilstva [Epistemology of the concept of "ecologization of agriculture" in the context of sustainable development of society]. *Modern Economics*, 13, 41–48. DOI: [https://doi.org/10.31521/modecon.V13\(2019\)-06](https://doi.org/10.31521/modecon.V13(2019)-06)

5. Honcharuk, I. V., Kovalchuk, S. Ya., Tsytsiura, Ya. H., & Lutkovska, S. M. (2020). *Dynamichni protsesy rozvytku orhanichnoho vyrobnytstva v Ukraini* [Dynamic processes of development of organic production in Ukraine]. Vinnytsia: TOV "Tvory".

6. Khodakivska, O. V. (2015). *Ekolohizatsiia ahrarnoho vyrobnytstva: monohrafiia* [Ecologization of agricultural production: a monograph]. Kyiv: NNTs IAE.

7. Shkuratov, O. I., Chudovska, V. A., & Vdovychenko, A. V. (2015). *Orhanichne silske hospodarstvo: ekoloho-ekonomichni imperatyvy rozvytku: monohrafiia* [Organic agriculture: ecological and economic imperatives of development: monograph]. Kyiv: TOV "Dia".

8. Tereshchenko, V. K., & Mylovanov, Ye. V. (2018). Rozvytok orhanichnoho silskoho hospodarstva yak faktor pryskorennia ekolohizatsii ahrovyrobnytstva [Development of organic agriculture as a factor in accelerating the ecologization of agricultural production]. *Visnyk ahrarnoi nauky – Bulletin of Agricultural Science*, 10(787), 75–83. DOI: <https://doi.org/10.31073/agrovisnyk201810-11>

9. Ukraine's greenhouse gas inventory 1990–2019. Annual National Inventory Report for Submission under the United Nations Framework Convention on Climate Change and the Kyoto Protocol. Kyiv, 526 p.

10. Proiekt Natsionalnoho kadastru antropohennykh vykydiv iz dzherel ta absorptsii pohlynachamy pamykovykh haziv v Ukraini za 1990–2018 roky [Draft National Cadastre of Anthropogenic Emissions from Sources and Absorption by Greenhouse Gas Absorbers in Ukraine for 1990–2018]. Retrieved from: https://menr.gov.ua/files/docs/Zmina_klimaty/2020/Ukraine_NIR_2020%20draft.pdf

11. Ofitsiinyi sait Derzhavnoi sluzhby statystyky Ukrainy [Official site of the State Statistics Service of Ukraine]. *ukrstat.gov.ua*. Retrieved from: <http://www.ukrstat.gov.ua/>

12. Ofitsiinyi sait Derzhavnoho ahenstva z enerhoefektyvnosti ta enerhozbereshennia v Ukraini [Official site of the State Agency for Energy Efficiency and Energy Saving in Ukraine]. *sae.gov.ua*. Retrieved from: <https://sae.gov.ua/uk>

13. Ofitsiinyi sait Bioenerhetychnoi asotsiatsii Ukrainy [Official site of the Bioenergy Association of Ukraine]. *uabio.org*. Retrieved from: <https://uabio.org/>

14. Vovk, V. Yu. (2020). Ekonomichna efektyvnist' vykorystannja bezvidk-hodnykh tekhnologij v APK [Economic efficiency of waste-free technologies in agro-industrial complex]. *Ekonomika, finansy, menedzhment: aktualni pytannia nauky i praktyky – Economics, finance, management: topical issues of science and practical activity*, 4, 186–206. DOI: <https://doi.org/10.37128/2411-4413-2020-4-13>

15. Kaletnik, G., Honcharuk, I., & Okhota, Yu. (2020). The Waste-Free Production Development for the Energy Autonomy Formation of Ukrainian Agricultural Enterprises. *Journal of Environmental Management and Tourism*, 11, 3, 513–522. DOI: [https://doi.org/10.14505/jemt.v11.3\(43\).02](https://doi.org/10.14505/jemt.v11.3(43).02)

16. Bakulina, H. Yu. (2017). Smittia – zahroza ekolohii chy bahatstvo krainy? Svitovyi dosvid i perspektyvy Ukrainy shchodo vyrobnytstva biohazu [Garbage – a threat to the environment or the wealth of the country? Ukraine’s world experience and prospects for biogas production]. *Ekonomika i suspilstvo – Economy and society*, 9, 803–808.

17. Perspektyvy rozvytku rynku biomasy v YeS i Ukraini. Vplyv vykorystannia biomasy za zminy klimatu [Prospects for the development of the biomass market in the EU and Ukraine. Impact of biomass use on climate change]. *uspp.ua*. Retrieved from: <https://uspp.ua/assets/doc/uspp-biomass.pdf>

18. European Biogas Association. *europeanbiogas.eu*. Retrieved from: <https://www.europeanbiogas.eu/>

19. Sydorhuk, O. (2020). Dosvid Yevropy ta svitu zastosuvannia biohazovykh tekhnolohii [Experience of Europe and the world of biogas technologies application]. *AgroExpert: praktychnyi posibnyk ahraryiv – AgroExpert: a practical guide for farmers*, 1(138), 104–107.

20. Hlotova, I. (2017). Biohazovi krainy: yak u sviti otrymuiut enerhetychnu nezalezhnist' [Biogas countries: how the world is gaining energy independence]. *Agravery*. Retrieved from: <http://agravery.com/uk/posts/show/12>

21. Bloomberg New Energy Finance. Climatescope. *global-climatescope.org*. Retrieved from: <http://global-climatescope.org/results>

22. Martyniuk, A. M., Sakaliuk, D. S., Mariuk, O. V., & Kholodova, N. V. *Enerhetychni kooperatyvy: enerhonezalezhnist' dlia hromad* [Energy cooperatives: energy independence for communities]. Kyiv: Hromadska orhanizatsiia “Ekoklub”.

23. Bundesgeschäftsstelle Energiegenossenschaften. *dgrv.de*. Retrieved from: <https://www.dgrv.de/bundesgeschäftsstelle-energiegenossenschaften/>

24. Zinchenko, A., Skliarov, R., & Bondarchuk, I. (2017). Enerhetyka spilnot. Yak enerhetychni kooperatyvy spryiaiat stiikosti hromad po vsomu svitu [Community energy. How energy cooperatives contribute to the resilience of communities around the world]. *Greencubator. Tsentr Ekonomichnoi Demokratii – Greencubator. Center for Economic Democracy*. Retrieved from: <https://feao.org.ua/news/energy-cooperatives-germany-austria/>

25. Zemelnyi dovidnyk Ukrainy-2020 [Land Directory of Ukraine-2020]. *mailchi.mp*. Retrieved from: <https://mailchi.mp/latifundistmedia/zemelyniy-dovidnyk-ukrainy-2020>

26. Honcharuk, I. V. (2020). Vyrobnycstvo bioghazu v aghrarnomu sektori – shljakh do pidvyshhennja energihetychnoji nezalezhnosti ta rodjuchosti ghruntiv [Biogas production in the agricultural sector is a way to increase energy independence and soil fertility]. *Aghrosvit – Agroworld*, 15, 18–29. DOI: <https://doi.org/10.32702/2306&6792.2020.15.18>

27. Yak u biogazovykh ustanovkakh dobryvo vyrobliaiut [As in biogas plants, fertilizer is produced]. *propozitsiya.com*. Retrieved from: <https://propozitsiya.com/ua/yak-u-biogazovykh-ustanovkah-dobryvo-vyroblayut>

28. Honcharuk, I. V., Vovk, V. Yu. (2020). Poniatiinyi aparat katehorii silskohospodarski vidkhody, yikh klasyfikatsiia ta perspektyvy podalshoho vykorystannia dlia vyrobnystva bioenerhii [Conceptual apparatus of the category of agricultural waste, their classification and prospects for further use for bioenergy production]. *Ekonomika, finansy, menedzhment: aktualni pytannia nauky i praktyky – Economics, finance, management: topical issues of science and practice activity*, 3, 23–38. DOI: <https://doi.org/10.37128/2411-4413-2020-3-2>

29. Honcharuk, I. (2020). Use of wastes of the livestock industry as a possibility for increasing the efficiency of AIC and replenishing the energy balance. *Visegrad Journal on Bioeconomy and Sustainable Development*, 9, 1, 9–14. DOI: <https://doi.org/10.2478/vjbsd-2020-0002>

30. Honcharuk, I. (2021). Energy needs of the agricultural sector and the potential for addressing them. *Humanities and Social Sciences*, 29(1), 95–113. DOI: <https://doi.org/10.22364/hssl.29.1.06>

31. Kaletnik, G. M. (2018). Diversification of production of biofuel – as the basis of maintenance of food, power, economic and environmental safety of Ukraine. *Bulletin of Agricultural Science*, 11(788), 169–176. DOI: <https://doi.org/10.31073/agrovisnyk201811-21>

32. Kyrylenko, I. H., Tokarchuk, D. M. (2020). Efektyvna orhanizatsiia vykorystannia vidkhodiv ahrarnykh pidprijemstv u formuvanni enerhetychnoi ta ekolohichnoi bezpeky [Effective organization of waste use of agricultural enterprises in the formation of energy and environmental security]. *Ekonomika, finansy, menedzhment: aktualni pytannia nauky i praktyky – Economics, finance, management: topical issues of science and practice activity*, 2, 66–84. DOI: <https://doi.org/10.37128/2411-4413-2020-2-9>

33. Tomashuk, I. V., & Krasnoselska, A. A. (2021). Vyrobnycstvo alternatyvnykh vydiv enerhetychnykh resursiv yak chynnyk pidvyshchennia efektyvnosti silskohospodarskykh pidprijemstv [Production of alternative types of energy resources as a factor in improving the efficiency of agricultural enterprises]. *Biznes-navihator – Business-navigator*, 6(67), 126–135. DOI: <https://doi.org/10.32847/business-navigator.67-23>

34. Kaletnik, H. M., & Pryshliak, N. V. (2021). Model bioenerhetychnoho klasteru vyrobnystva biopalyva z silskohospodarskykh kultur ta vidkhodiv [Model of bioenergy cluster of biofuel production from crops and waste]. *Ekonomika, finansy, menedzhment: aktualni pytannia nauky i praktyky – Economics, finance, management: topical issues of science and practice activity*, 1(54), 26–42. DOI: <https://doi.org/10.37128/2411-4413-2021-1-2>

35. Pryshliak, N., Tokarchuk, D., & Shevchuk, H. (2021). The socio-economic and environmental importance of developing biofuels: the Ukrainian case on the international arena. *Polityka Energetyczna – Energy Policy Journal*, 24(1), 133–152. DOI: <https://doi.org/10.33223/epj/131829>
36. Honcharuk, I. V., & Vovk, V. Yu. (2021). Waste-free technology's for the production of biofuels from agricultural waste as a component of energy security of enterprises. *Development of scientific, technological and innovation space in Ukraine and EU countries: collective monograph*. Riga, Latvia: Publishing House “Baltija Publishing”, 142–165. DOI: <https://doi.org/10.30525/978-9934-26-151-0-37>
37. Palamarchuk, V., Honcharuk, I., Honcharuk, T., & Telekalo, N. (2018). Effect of the elements of corn cultivation technology on bioethanol production under conditions of the right-bank forest-steppe of Ukraine. *Ukrainian Journal of Ecology*, 8(3), 42–50.
38. Mazur, V., Didur, I., Pansyryeva H., & Telekalo, N. (2018). Energy-economic efficiency of growth of grain-crop cultures in conditions of right-bank forest-steppe zone of Ukraine. *Ukrainian Journal of Ecology*, 8(4), 26–33.
39. Palamarchuk, V., Krychkovskiy, V., Honcharuk, I., & Telekalo, N. (2021). The Modeling of the Production Process of High-Starch Corn Hybrids of Different Maturity Groups. *European Journal of Sustainable Development*, 10(1), 584–598.
40. Tokarchuk, D. M., Pryshliak, N. V., Tokarchuk, O. A., & Mazur, K. V. (2020). Technical and economic aspects of biogas production at a small agricultural enterprise with modeling of the optimal distribution of energy resources for profits maximization. *INMATEH – Agricultural Engineering*, 61(2), 339–349.
41. Skoruk, O. P., Tokarchuk, D. M., & Vsemirnova, V. M. (2011). Perspektyvy vyrobnytstva biopalyva tretoho pokolinnia [Prospects for the production of third generation biofuels]. *Zbirnyk naukovykh prats VNAU. Seriya: Ekonomichni nauky – Collection of scientific works of VNAU. Series: Economic Sciences*, 1(48), 171–176.
42. Kupchuk, I. M., Yaropud, V. M., Telekalo, N. V., & Hraniak, V. F. (2020). Perspektyvy taperedumovy vprovadzhenia avtonomnykh system elektrozabezpechennia ahropromyslovykh pidpriemstv [Prospects and prerequisites for the introduction of autonomous power supply systems of agro-industrial enterprises]. *Tekhnika, enerhetyka, transport APK – Engineering, energy, transport of agro-industrial complex*, 3(110), 51–63. DOI: <https://doi.org/10.37128/2520-6168-2020-3-5>
43. Kaletnik, G., Honcharuk, I., Yemchyk, T., Okhota Yu. (2020). The World Experience in the Regulation of the Land Circulation. *European Journal of Sustainable Development*, 9(2), 557–568. DOI: <https://doi.org/10.14207/ejsd.2020.v9n2p557>
44. Pryshliak, N. V., Tokarchuk D. M., & Palamarenko Ya. V. (2019). *Zabezpechennia enerhetychnoi ta ekolohichnoi bezpeky derzhavy za rakhunok biopalyva z bioenerhetychnykh kultur i vidkhodiv* [Ensuring energy and environmental security of the state through biofuels from bioenergy crops and waste]. Vinnytsia: Konsol.
45. Tokarchuk D. M., Furman I. V. (2020). Suchasni enerhoefektyvni tekhnologii v APK Ukrainy [Modern energy efficient technologies in the agro-industrial complex of Ukraine]. *Ekonomika, finansy, menedzhment: aktualni pytannia nauky i praktyky – Economics, finance, management: topical issues of science and practice activity*, 4(54), 99–116. DOI: <https://doi.org/10.37128/2411-4413-2020-4-7>

**THEORETICAL GROUNDS OF ASSESSING THE
PROBABILITY OF AN ENTERPRISE BANKRUPTCY UNDER
THE CONDITIONS OF THE PANDEMIC AND ITS IMPACT
ON EXPORT-IMPORT OPERATIONS IN UKRAINE**

Lyudmila Volontyr¹

DOI: <https://doi.org/10.30525/978-9934-26-193-0-3>

Abstract. *The purpose* of the work is to study the transformation of the concept of bankruptcy in Ukraine and the world in pandemic conditions, carrying out econometric modeling of exports and imports and taking into account seasonal fluctuations and their forecasting. *Methodology.* The paper considers the legal settlement of the grounds, procedures and consequences of the debtor's insolvency. The concept of "bankruptcy" is used in many socio-political and natural sciences where it is given its own interpretation. The most typical definitions of the concept of "bankruptcy" that occur in foreign and domestic scientific publications are considered. Studying the chronology of the "bankruptcy" concept interpretation allows us to assess the change of positions and approaches to understanding its essence. It is emphasized that bankruptcy should be investigated as a method of anti-crisis management. The classification of bankruptcy on various grounds is considered. Introductions in the regulatory framework concerning bankruptcy are considered. Econometric modeling has shown that the exports and imports of goods, works and services of Ukraine has a general tendency to decrease and seasonal fluctuations have a significant impact on them. *Practical implications.* Introductions into the regulatory framework concerning bankruptcy, namely the procedure for the out-of-court recovery and the procedure for initiating a simplified bankruptcy procedure of the debtor, are liquidated by the owner. These provisions make it possible to make national insolvency and bankruptcy legislation more flexible and adapt it to European legislation. Particular attention is paid to legal relations associated with bankruptcy, which are governed by a number of regulations of different legal force that together constitute a separate institution in

¹ Candidate of Technical Sciences, Associate Professor,
Vinnytsia National Agrarian University, Ukraine

the system of economic legislation. The analysis of bankrupt enterprises in Ukraine in 2016–2019 revealed that most enterprises in Ukraine went bankrupt in 2016, the least – in 2019, i.e., there is a downward trend in this indicator, which indicated a gradual improvement in Ukraine’s economic situation. Most companies went bankrupt in February 2017, the least – in November 2019. Based on econometric modeling, the forecast of exports and imports is determined and, taking into account seasonal fluctuations, we determine their values for each quarter of 2021–2023. The largest volume of exports falls on the third quarter, while the largest volume of imports – on the fourth. As a result of the study, based on the analysis of the dynamics of exports, imports and gross domestic product of Ukraine during 2010–2020, it was found that exports and imports of goods and services had a general tendency to decrease. *Value/originality*. Effective management of export-import operations is impossible without a science-based approach to solving a set of problems of their information support. In a pandemic, businesses need to respond quickly to environmental conditions. Risks arising from quarantine measures need to be minimized immediately. The analysis of the dynamics of exports, imports, gross domestic product of Ukraine during 2010–2020 revealed that the balance of foreign economic transactions, in particular the value of exports of goods and services, has a significant impact on Ukraine’s gross domestic product. The constructed econometric model of dependence of GDP upon exports and imports of Ukraine is adequate (determination coefficient is 0.963). It is substantiated that with the increase in exports by UAH 1 million, gross domestic product will decrease by UAH 11.89 million provided that the remaining factors remain unchanged. If the volume of imports is increased by UAH 1 million, the gross domestic product will increase by UAH 4.51 million. provided that the remaining factors stay unchanged. The values of the coefficients of import dependence and export coverage of imports were analyzed and it was noted that these indicators significantly exceed the allowable level during almost the entire study period. The negative balance of export-import operations in 2010–2020 also indicates some imbalances in Ukraine’s foreign trade relations. During 2014–2020, there was a reverse, unfavorable for Ukraine trend of lower value of exports of goods and services compared to their imports. Note that the best values do not always match.

1. Introduction

The prevailing opinion in society is that the bankruptcy of an enterprise is bad, it has no positive consequences for the enterprise and will inevitably result in its liquidation. In fact, this is not the case. Bankruptcy proceedings in the case of the right approach gives a chance to business for a “second life”.

Bankruptcy is a natural phenomenon of a market economy – unprofitable, inefficient and insolvent enterprises cease to operate. However, under the current unstable economic conditions, a significant number of enterprises have found themselves in a difficult financial situation. Quite often, companies fail financially due to unpreparedness for sudden crises or any other changes in the economy.

Under the conditions of the economic crisis, the issue of determining the probability of bankruptcy of enterprises is particularly acute, as the number of bankrupt enterprises is growing [35, p. 683].

The Bankruptcy Institute in Ukraine has come a long way. In Soviet times, the insolvency procedure was regulated, but practically not applied. Only the proclamation of Ukraine as an independent state and the determination of the economic vector for the development of market relations contributed to the revival of the institution of bankruptcy. In this regard, there is a need for legal regulation of the grounds, procedures and consequences of insolvency of the debtor.

Foreign economic activity is the activity of economic entities of Ukraine and foreign economic entities, built on the relationship between them, which takes place both in Ukraine and abroad.

Export-import transactions remain the main source of foreign exchange earnings of resident enterprises. The creation of favorable legislative and tax conditions for Ukrainian enterprises in the field of export-import operations will stimulate an increase in foreign currency inflows into the country.

The formation and development of the domestic economy depends on solving the problem of foreign economic relations, because they play a significant role in the national economy, significantly affect the pace of economic growth in Ukraine. Effective management of export-import operations is impossible without a science-based approach to solving a set of problems of their information support, which are solved in the system of accounting and analysis.

Thus, the issue of assessing the changes of export-import transactions of Ukraine in a global pandemic and forecasting this changes taking into account seasonal fluctuations is relevant.

**2. Bankruptcy of the enterprise:
the essence and content characteristics**

There are many interpretations of the term “bankruptcy” in the scientific, economic and legal literature. This concept is used in many socio-political and natural sciences, each of which gives it its own interpretation. The reason for the existence of a large number of definitions is the many-sidedness of this concept, ambiguity in its manifestations and rather often, unexpected consequences. The theoretical substantiation of this phenomenon continues to this day. In this regard, it is advisable to consider the most common definitions of “bankruptcy” that occur in foreign and domestic scientific publications (Table 1).

Table 1

Interpretation of the concept of “bankruptcy”

Author, source	Definition
1	2
E. M. Andrushchak [1]	Bankruptcy is an unsatisfactory economic situation of a natural or legal person recognized by the judicial agencies, which is a sign of termination of payments on liabilities due to lack of assets in realizable form.
O. Ya. Bazylynska [3]	Bankruptcy is the inability of an enterprise to pay its debts and meet its budget obligations.
I. A. Blank [4, p. 406]	Bankruptcy of enterprises is a financial insolvency of an enterprise established in court, i.e. the inability of an enterprise to meet the requirements set for it by creditors within the time limits set and to fulfill obligations to the budget.
R. Breli and S. Myers [6]	Bankruptcy is a market way of punishing a company for large-scale management mistakes. Bankruptcy is associated with the realization of catastrophic risks that have arisen in the course of its failed financial and economic activities.
I. M. Boichyk [5]	It is the incapability for some entities to meet their obligations to creditors after the deadline, especially it concerns the accounts payable.
T. E. Voronkova, N. P. Rybalchenko [41]	Bankruptcy – “is a fundamental, legal category of the economy of Ukraine”, “financial insolvency of the debtor and non-payment of obligations.”
V. I. Hrynychtskyi [12]	The inability of the debtor to restore its financial solvency and satisfy the creditors’ claims recognized by the arbitration court only through the application of the liquidation procedure.

(Continuation of Table 1)

1	2
O. D. Danilov, T. V. Paientko [7]	The inability of the enterprise to satisfy creditors' claims for payment for goods (works, services) including the inability to ensure mandatory payments to the budget and extrabudgetary funds, due to excess liabilities of the debtor over its property or due to unsatisfactory structure of the debtor's balance sheet.
I. V. Oleksandrenko, L. I. Ishchuk [23]	Regulatory authority of a market economy, whose task is to exclude inefficient and insolvent, unprofitable economic entities.
T. V. Pepa [25, p. 10]	Bankruptcy means the refusal of a citizen or company to pay on its own debt due to lack of funds.
O. L. Plastun [26]	This is the inability of a legal entity – a business entity – to meet the requirements of its creditors within the time limits set due to the lack of assets in realizable form.
S. M. Skochyliias [34]	Bankruptcy characterizes the inability of the company to meet creditors' claims for payment for goods, works and services, as well as to ensure mandatory payments to the budget and extra-budgetary funds.
H. O. Sukrusheva, B. M. Paputsyn [35, p. 684]	Bankruptcy of the enterprise is a consequence of the deep financial crisis of the enterprise, which leads to the refusal to finance the main current activities due to lack of funds, and the refusal to pay on its own debt, which is the basis for liquidation
O. O. Tereshchenko [37, p. 13]	Bankruptcy of enterprises is a consequence of a deep financial crisis, the system of management measures of which has not had positive effect.
O. Tretiak [38]	Gives consideration to bankruptcy as the result of an entity's insolvency. According to him, bankruptcy is a lack of assets in realizable form, the inability of a legal entity – a business entity to meet the requirements of its creditors within the time limits set.
N. P. Shmorhun [33, p. 86]	Bankruptcy (financial collapse) is the documented inability of an entity to pay its liabilities and finance its current activities due to lack of funds. This state of the enterprise, according to the author, indicates the performance degradation that determine its financial stability.
A. S. Yablonska [14]	Bankruptcy is one of the legal grounds for liquidation of the enterprise, which is manifested in the incapacity of the business entity to meet the creditors' claims and obligations to the budget within the prescribed period.

(End of Table 1)

1	2
T. M. Yankovets, Yu. V. Cherniuk [15]	Bankruptcy is considered as: 1) financial insolvency and collapse, which cause the inability of the company to pay its liabilities; 2) inability to restore the solvency of the debtor through reorganization, amicable agreements in accordance with the law, the use of liquidation proceedings) recognized through the courts.
Explanatory dictionary [46]	It is a financial failure, a collapse that leads to the suspension of debt payments.

Source: summarized by the author according to sources

Studying the chronology of the interpretation of the concept of “bankruptcy” allows us to assess the change of positions and approaches to understanding its essence. Thus, the market approach proposed by Oleksandrenko I. V. and Ishchuk L. I. [23] proves that bankruptcy is a natural mechanism for cleaning the economy of unprofitable, inefficient enterprises. Sukrusheva G. O., Paputsyn V. M. [35] also hold the following opinion: in fact, it is a natural mechanism for selecting the most efficient enterprises that have the resources to operate in a crisis. Voronkova T.E. and Rybalchenko N. P. hold a similar opinion [44]: “The concept of bankruptcy is based on a simple rule of the free market: in a competitive environment, those companies shall survive whose activities are more efficient and whose products are in demand.”

Yankovets T. M., Cherniuk Yu. V. [15] consider bankruptcy from the point of view of internal financial insolvency of settlement on debt obligations – conditions under which the enterprise is declared bankrupt (court decision, impossibility of reorganization, conclusion of amicable agreements, need for liquidation procedure). This approach clearly defines the tools for overcoming bankruptcy, but does not take into account the root causes of bankruptcy. For example, such reasons may be the ineffectiveness of crisis management: lack of receivables management, monitoring the financial condition of debtors, risk forecasting, forecasting income and expenses, cash flows, understanding macroeconomic trends and more.

Sukrusheva G. O., Paputsyn V. M. [35] systematized the concept of “bankruptcy”, which allows to form the main conditions for declaring an enterprise a bankrupt:

1. Legal grounds, in particular the court's recognition of the inability to pay on debt obligations, which is documented.
2. Inability to settle with creditors in a timely manner.
3. Impossibility of reorganization or amicable settlements.
4. The need for liquidation.
5. Impossibility of anti-crisis measures to overcome financial insolvency and recognition of the company's own financial insolvency.

Bankruptcy is often seen as a phenomenon caused by a crisis that could not be overcome in time. Most authors agree that bankruptcy should be prevented in any case and new and more effective methods of enterprise management should be sought to prevent this phenomenon.

Bankruptcy is considered more deeply among foreign scholars from a legal point of view, given the improvement of laws governing the bankruptcy of enterprises (R. Efrat [8], T. Ziviki [44], S. Lin [18]).

However, bankruptcy should also be investigated as a method of crisis management, but with the caveat that this method should be used only as a last resource when the crisis in the company is completely out of control. Research on bankruptcy proceedings was conducted mainly in terms of revealing the essence of this concept as a negative phenomenon for the company. B. Moskvina believes that it is advisable to explore the concept of "bankruptcy" as a last resource for the owners and management of the company once and for all to overcome the crisis in the company and solve the problem of debt to creditors [21, p. 59].

The diversity of views of scientists is due to the influence of factors of both external and internal nature, and the presence of most of the considered interpretations reflects an understanding of the degree of influence of a factor. In our opinion, it is appropriate to define bankruptcy as an economic phenomenon that occurs when a company is unable to meet its obligations to its creditors, so it is forced to cease its activities without resuming it in the future.

The causes of bankruptcy are divided into external (exogenous) and internal (endogenous). External factors include crisis-making factors: economic, political, social ones, due to the imperfection of public policy, as well as factors of negative inheritance (inherited from the command-administrative system); inflation and default crisis; market factors (negative market conditions); factors of interaction with partners; innovation factors; resource deficit; natural disasters.

Internal causes include: imperfection of the enterprise potential management system (managerial, marketing, labor, financial, rehabilitation, infrastructure, information, reproduction potential), irrational management decisions, production potential, etc.

The main causes of bankruptcy are presented in Figure 1.

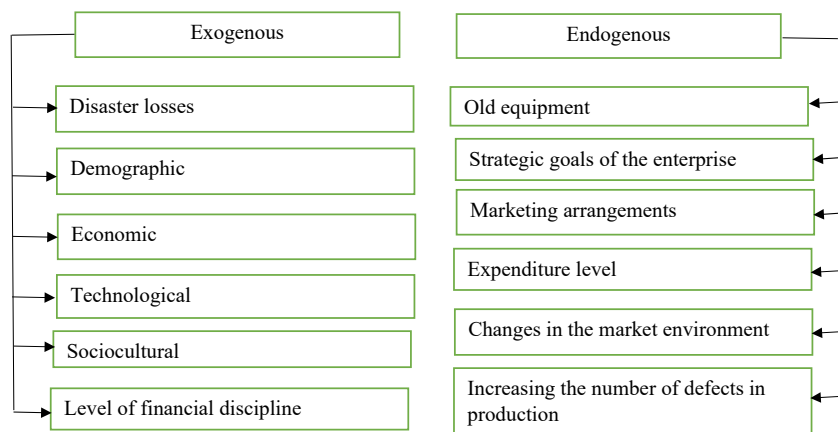

Figure 1. Causes of bankruptcy

Source: [40, p. 63]

Other authors believe that the causes of bankruptcy are financial crises [37, p. 13–15], which are caused by exogenous (economic downturn, declining purchasing power, high inflation, instability of economic and tax legislation, instability of financial and foreign exchange markets, increasing competition in the industry, crisis of a particular industry, seasonal fluctuations, discrimination by the government authorities, etc.) and endogenous factors (low quality of management, deficiencies in the organizational structure, low staff skills, shortcomings in the production sector, miscalculations in the supply sector, low level of marketing and loss of markets, miscalculations in investment policy, lack of innovation and efficiency drive, deficits in funding, lack or unsatisfactory performance of control services). It is obvious that the reasons will vary depending on the country, region, industry, size of the enterprise, form of ownership of the enterprise and its organizational and legal status, and so on.

Therefore, it is advisable to consider the new for today causes of bankruptcy of the enterprise, which arise as a consequence of the development of the world economy and foreign economic relations between market participants, as well as identify the causes of bankruptcy inherent to the domestic economy, and try to classify these causes into groups in order that the company optimized the resource spend when analyzing the causes of bankruptcy and developing elements of bankruptcy prevention.

The current causes of bankruptcy include:

- 1) increased role of TNCs, increase of large companies through mergers, acquisitions, and hence the level of competition;
- 2) growth of requirements and needs of consumers to products of enterprises;
- 3) increase of the share of knowledge-intensive products and services;
- 4) significant reduction in the life cycle of goods and services;
- 5) interdependence of economies of different countries and the possibility of a “domino effect” during financial and economic crises and bankruptcies (for example, the crisis of 2008, which affected many countries and caused negative consequences in the financial system of Ukraine);
- 6) an increase in the number of terrorist acts in the world;
- 7) increased restrictions on environmental protection, vigorous activities of environmental organizations;
- 8) Internet crimes and virtual fraud;
- 9) growth of natural disasters and the number of man-made accidents;
- 10) dynamism and turbulence of the world economy;
- 11) corporate scandals due to sexual harassment of employees [37, p. 61].

In developed countries with market economies, with stable political and economic systems, bankruptcies by 1/3 are mainly due to external factors and by 2/3 due to internal ones. Thus, it can be concluded that, firstly, the bankruptcy of economic entities under the conditions of their improper regulation can cause great damage to the state economy, and secondly, the state should take care to reduce the impact of external risks on national enterprises. And for this, it is necessary to have an adequate legal framework.

In general, the causes of bankruptcy of enterprises and organizations can be divided by characteristics into certain types (Table 2).

Thus, analyzing the statistics and causes of bankruptcy, we conclude that the largest number of bankruptcies occurs in the economy of a country experiencing

a recession or transformation. A similar situation is observed in the industries. If the industry is in the final stages of development or the demand for its products is falling in the market, the number of bankruptcies increases significantly. Other important causes of bankruptcy are the internal problems of the enterprise itself. Therefore, in the future it is necessary to develop approaches to the various stages of development of the economy, industry and enterprise.

Regarding the classification of bankruptcy, the following types of bankruptcy of enterprises are distinguished in legislative and financial practice (Table 3).

There are different ways to classify the phenomenon of bankruptcy. In particular, on the basis of the bankruptcy cause, we distinguish:

- 1) bankruptcy of the business (associated with inefficient management of the enterprise, marketing strategy or use of available resources);
- 2) bankruptcy of the owner (caused by lack of investment resources of the owner, necessary for the implementation of extended and sometimes simple reproduction);
- 3) bankruptcy of production (non-competitiveness of products);
- 4) the so-called “unconscionable management” – the actions of the company’s management associated with malicious evasion of obligations [32, p. 129].

Diagnostics of the crisis in the enterprise is a set of methods aimed at identifying negative performance indicators, in particular the problems that are the causes of poor financial condition (Table 4).

3. Statutory regulation of relations in the field of enterprise bankruptcy

The Law of Ukraine “On Bankruptcy” enacted by the Resolution of the Verkhovna Rada of Ukraine dated 05/14/1992 № 2344-XII [29], which was in force for seven years, became a novelty in the domestic legal field but it outlined only the state regulation of financial insolvency system and had significant shortcomings. First of all, the Law of Ukraine “On Bankruptcy” did not provide for the establishment of a specialized state regulatory body for bankruptcy, as well as the existence of one of the main figures in the bankruptcy procedure – arbitral trustee (property administrator, reorganization manager, liquidator).

On January 1, 2000, the Law of Ukraine dated June 30, 1999 № 784-XIV “On Restoration of Debtor’s Solvency and Recognition of

Classification of bankruptcy causes

No.	Signs of bankruptcy causes	Types of bankruptcy causes
1.	By way of fixing	regulatory (formal) illegal/unlawful (informal)
2.	By level of control	manageable potentially manageable unmanageable
3.	By period of influence	static dynamic
4.	By elements of origin	social psychological economic natural and ecological political administrative and legislative scientific and technical organizational
5.	By place of origin in the organization	corporate of units
6.	By level of occurrence	strategic operational
7.	By action mechanism	direct indirect
8.	By stages of operation of the enterprise	reasons at the stage of establishment of the enterprise reasons at the stage of growth and maturity reasons at the stage of liquidation of the enterprise
9.	By scale	global regional local industrial
10.	By types of resources involved	informational energy financial material labor
11.	By stages of activity in a certain field	entering the market functioning exit from the market

Source: [13, p. 62]

Bankruptcy classification

Type	Essence
Concealed bankruptcy	is considered as intentional concealment of his stable financial insolvency by providing inaccurate information by the founding citizen, owner or official of the business entity if it caused great material damage to the creditor
Fictitious bankruptcy	the essence of this type is to erroneously declare the company insolvent in order to mislead creditors to obtain from them a deferral (installment) of their credit obligations or reduce the amount of credit debt
Real bankruptcy	characterizes the complete inability of the company to restore in the future its financial stability and solvency due to real losses of capital used
Technical bankruptcy	characterizes the complete inability of the company to restore in the future its financial stability and solvency due to the actual loss of capital used. There is an excess of receivables over accounts payable, and the amount of assets – over liabilities
Intentional bankruptcy	characterizes the intentional creation (or increase) of the head or owner of the enterprise of its insolvency; infliction of economic damage to the enterprise in personal interests or for the benefit of others; incompetent financial management

Source: [40, p. 63–64]

Bankruptcy” [30] entered into force, and thus the next stage of development of state regulation in the field of bankruptcy was started. The benefits of the new Law, which expired with the introduction in 2019 of the Bankruptcy Code of Ukraine, at that time, were undeniable.

First, the Law established the conditions and procedure not only for declaring the debtor bankrupt, but also for restoring his solvency and applying the liquidation procedure, full or partial satisfaction of creditors’ claims. As a result, the Law had more articles than the previous Law that were consistent and logical.

Secondly, the glossary covered in Article 1 of the Law has been expanded. In particular, the concept of “bankruptcy”, which is used in the sense of recognizing the debtor’s inability to restore its solvency and satisfy the creditors’ claims recognized by the court, has been improved against the background of experience gained through the liquidation procedure.

Third, the existence of a state bankruptcy body and its powers have been enshrined de jure.

Stages of crisis development in the enterprise

Stages of the crisis	External manifestations
Latent crisis	<ol style="list-style-type: none"> 1. Decrease in efficiency of activity 2. Performance degradation 3. Increasing the duration of operating and financial cycles 4. Decrease in market value of the enterprise 5. Receipt of losses on individual transactions
Paying capacity crisis	<ol style="list-style-type: none"> 1. Periodic and ever-increasing shortage of funds 2. Delay in payment of current payments 3. The emergence of overdue accounts payable and outstanding loans 4. Payment of economic sanctions for breach of deadlines
Bankruptcy	<ol style="list-style-type: none"> 1. Inability to meet external obligations within three months of their occurrence 2. The enterprise creditors' appeal to the court 3. Initiation of bankruptcy proceedings at the initiative of the enterprise or its creditors

Source: [9]

This normative-legislative act has been used for a short time due to significant changes in the economy of Ukraine due to both the crisis in the world economy and domestic socio-economic and political problems. All this necessitated the improvement of regulatory and legal support for insolvency and bankruptcy procedures through the development of legislation and the Verkhovna Rada of Ukraine on December 22, 2011 adopted the Law of Ukraine “On Amendments to the Law of Ukraine on Restoration of Debtor’s Solvency or Bankruptcy” № 4212-VI, which entered into force on 01/19/2013 [30].

Special attention should be paid to such innovations in the bankruptcy legislation as the procedure for pre-trial reorganization and the procedure for initiating a simplified bankruptcy procedure of the debtor, which is liquidated by the owner himself. According to B. Volvach, today these provisions allow to more flexibly adapt national legislation on insolvency and bankruptcy to European law and increase the level of civilization to address these issues in the future [41, p. 5].

Particular attention should be paid to the relationship in respect of bankruptcy, which is governed by a number of regulations of different legal force, which together constitute a separate institution in the system of economic law. Regulations of this institute can be divided into three types:

1) legislative acts of general scope, containing certain rules regarding the regulation of relations in respect of bankruptcy (Commercial Code [11], Civil Code [38]);

2) legislative acts that determine the legal status of certain types of entities with an exceptional type of activity (banks, mutual investment institutions, insurance companies) or of a certain organizational and legal form (cooperatives, companies, farms) and contain certain rules on the possibility of recognition such entities as bankrupts;

3) special legislative acts governing the procedure for declaring business entities bankrupt.

The existence of gaps, the huge number of regulations adopted haphazardly, their low quality and sometimes inconsistencies on the one hand, as well as the importance and complexity of relations in this area, on the other hand, necessitated reform of bankruptcy legislation to reduce the length of bankruptcy proceedings, ensure an adequate level of protection of creditors' rights and reduce abuses in this area, as well as improve Ukraine's position in the Doing Business rating, which would improve the investment climate in the country.

Therefore, in order to reform the legislation in this area and solve the tasks set, the Code of Ukraine on Bankruptcy Procedures was adopted on 10/18/2018 № 2597-VIII (KUzPB № 2597-VIII) [24], which initiated the fourth stage of the development of bankruptcy legal regulation in Ukraine. The introduction of the Bankruptcy Code of Ukraine allowed to unify the legal framework and bring it in line with international standards [43], in addition to comprehensive regulation of relations in the field of bankruptcy regulation of legal entities, the main novelty of the Code was the introduction of debt settlement mechanism and other changes:

- the opening of bankruptcy proceedings by removing the restriction on the amount of debt was simplified;

- the deadline for filing an application by the creditor after the publication of the opening of proceedings has been canceled;

- the terms of bankruptcy proceedings were reduced to 170 calendar days without the right to extend;

- the powers of the court in which the debtor's bankruptcy case is pending have been increased;

- the creditors' committee or other creditors have been granted the right to independently convene a meeting;

- the creditors’ committee has been granted the right to approve the sale of the debtor’s property in liquidation and reorganization procedures, and the secured creditor has been granted the right to sell the property that is the subject of a collateral;
- the debtor’s management rights in the introduction of the procedure for disposing of property has been significantly reduced;
- the mechanism of sale of assets has been improved;
- joint (shared) liability of its management has been added to the subsidiary (additional) liability of the beneficial owners of the debtor;
- the terms of non-recognition of agreements that are unfavorable for the debtor or creditors has been extended to three years;
- new standards of activity of the arbitration trustee have been established;
- the amicable agreement has been canceled as one of the types of bankruptcy proceedings;
- the possibility of conducting a simplified bankruptcy procedure by the debtor has been abolished.

According to I. V. Minchynska, determining the peculiarities of the legislative regulation of bankruptcy in Ukraine would not be complete without determining the type of model of state legal regulation of these relations. The model of state legal regulation of bankruptcy is determined by the target direction of legislation in this area: maximum preservation of business and jobs of insolvent debtor or maximum return of funds to creditors during its liquidation, which generally distinguishes two legal theories: “pro-debit”, which prioritizes the interests of the debtor who is in a crisis mode and cannot pay debts on their obligations, and “pro-creditor”, which rather protects the interests of creditors. In our opinion, directing the legislation to the formation of one or another model of state regulation of bankruptcy is important, as giving preference to liquidation or reorganization procedures that can be used against insolvent debtors is economically important for the continued functioning of the economic system as a whole. Therefore, the assessment of legal regulation in this area also requires determining the type of bankruptcy state regulation model [22].

Analysis of the legal framework for regulating the bankruptcy institution in Ukraine makes it possible to develop a mechanism for its state regulation (Figure 2).

Definition of the concept of “bankruptcy” according to previous and current laws and statutory instruments of Ukraine are given in Table 5.

Official statistics on the parameters of the market for restructuring and insolvency in Ukraine are not presented.

According to market participants, the resolving insolvency indicators (resolution on insolvency) are at the following level:

- the average duration of litigation, in which the financial recovery of the debtor or the debtor's bankruptcy is carried out, is 2.9 years;
- the costs of supporting the bankruptcy proceedings are greater than or equal to 40.5% of the value of the debtor's property;
- the debt collection index, according to various estimates, ranges within 9%.

These modest indicators are reflected in the low Doing business rating. Ukraine ranked 146th in terms of resolving insolvency [2].

In the European Union, bankruptcy, to use a well-known terminology, is not recognized as an independent branch of law. Bankruptcy regulations are not singled out. However, rules aimed at regulating the insolvency of legal entities can be found in some specific areas of the EU legal framework. Bankruptcy in European countries is considered an important part of company law. In case of termination of the insolvent legal entity, special rules are applied for equal distribution of proceeds from the sold property of such a person [41, p. 8]. EU law guarantees individuals the right to freely participate in the capital of any company, regardless of the country in which it is registered. Another aspect of this right is the obligation to return the funds invested in the company, including in the event of its insolvency. Therefore, in the EU, bankruptcy proceedings as an element of a market-oriented economy are an important legal means of resolving debt problems in the structure of company law.

Bankruptcy in EU law is also linked to competition law in the field of economic governance. It is known that in this intergovernmental organization special attention is paid to legal means of maintaining fair competition. It should be noted that competition law is considered the area of legal regulation of private relations, which should be the subject of harmonization of legislation of countries-candidates for EU membership. The above is directly related to the law of bankruptcy, as bankruptcy procedures are the market mechanisms that guard fair competition, help regulate property relations between participants in economic relations without direct state intervention. Today in the EU, there is a special normative act regulating insolvency relations in cross-border cases – this is the Council Regulation 1346/2000 dated 05/29/2000 on insolvency proceedings (the Council

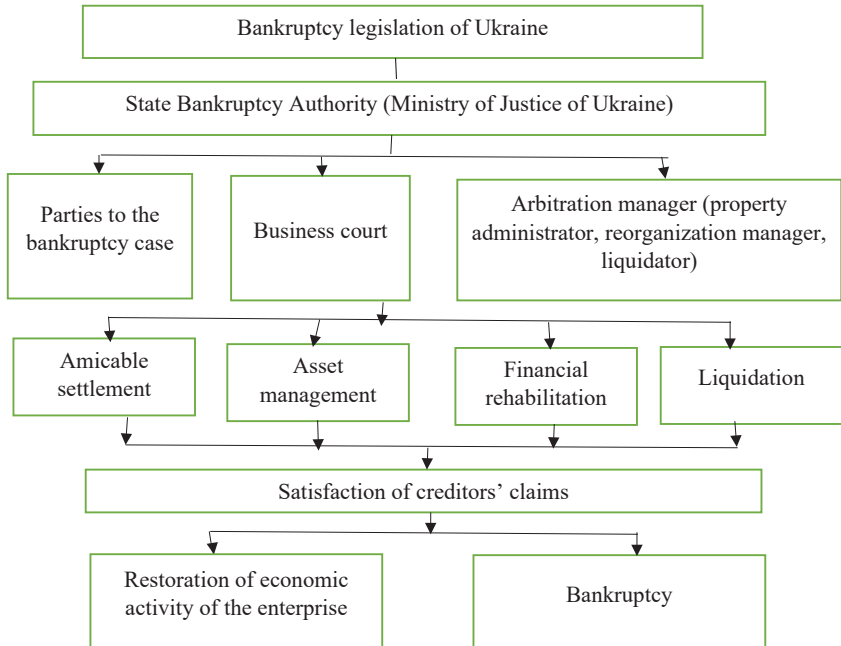

Figure 2. The mechanism of an enterprise bankruptcy state regulation in the economy of Ukraine

Source: supplemented by the author according to [17, p. 11]

Regulation 1346/2000/EC dated 29 May 2000 on insolvency proceedings) [28]. The main task of the drafters of the Regulation was to implement a system of measures to resolve problems in cross-border bankruptcies by ensuring the coordination of litigation in multiple bankruptcy cases.

4. The impact of the pandemic on the bankruptcy probability (according to Ukraine data)

Changing the political situation in Ukraine, changing the government, fighting in the east of the country and the COVID-19 outbreak have led to increased defense and medical spending, destruction of production facilities, infrastructure and transport, loss of land use, population run-down and decreased productivity indicators. The above factors have a negative impact

**Definition of the term “bankruptcy”
in laws and statutory instruments**

Source	Definition
1	2
Economic Code of Ukraine (Article 209) [11]	Bankruptcy is the inability of the debtor to restore its solvency and satisfy the creditors’ claims recognized by the court differently than through the application of the liquidation procedure determined by the court.
Civil Code of Ukraine (Article 53) [39]	An individual who is unable to satisfy the creditors’ claims related to his/her business activity may be declared bankrupt in accordance with the procedure established by law.
Bankruptcy Code of Ukraine (Article 1) [16]	Bankruptcy is the inability of the debtor recognized by the Commercial Court to restore its solvency through the procedure of rehabilitation and restructuring and repay the monetary claims of creditors established in the manner prescribed by this Code differently than through the liquidation procedure
Law of Ukraine “On restoring the debtor’s solvency or declaring him bankrupt” (Article 1) [29; 30]	Bankruptcy of an enterprise is the inability of a debtor recognized by a commercial court to restore its solvency through reorganization and amicable settlement procedures and to repay creditors’ monetary claims established in accordance with the law, differently than through the liquidation procedure.
Methodological recommendations of the NBU on the application of the Bankruptcy Law of Ukraine “On Bankruptcy” (paragraph 2) [19]	Bankruptcy is the inability of a legal entity – a business entity to meet creditors’ claims in a timely manner, repay bank loans and ensure mandatory payments to the budget.
Methodical recommendations of the Central Union of Consumer Societies of Ukraine on the analysis and assessment of the financial condition of enterprises (Chapter 2) [20]	Bankruptcy is the inability of an enterprise to pay its debts, which may be due to competition, incompetent management, stock market speculation, and so on.

Source: summarized by the author according to these sources

on GDP and the national economy as a whole, which, in turn, had a negative impact on businesses that have been subject to bankruptcy proceedings [2].

The statistics of bankrupt enterprises in Ukraine for 2016–2019 according to the Global Bankruptcy Report presented by Dun & Brad Street Worldwide Network [10], is presented in Table 6. It is not possible to present the statistics for 2020, as the data on Ukraine are not presented in the company's report for last year.

As can be seen from the Table, most enterprises in Ukraine went bankrupt in 2016, the least – in 2019, i.e. there is a downward trend in this indicator, which showed a gradual improvement in the economic situation in Ukraine. Most companies went bankrupt in February 2017, the least – in November 2019.

It is known that the Bankruptcy Procedure Code of Ukraine came into force on October 21, 2019 but the global COVID-19 pandemic decided to make its own adjustments. Under such conditions, the Code cannot be applied normally, then dire consequences are inevitable. Therefore, on April 10, 2020, the Verkhovna Rada of Ukraine registered the first draft law № 3322 on Amendments to the Bankruptcy Procedure Code of Ukraine to prevent bankruptcy abuses for the period of measures aimed at preventing the emergence and spread of COVID-19, which was adopted on 18.06.2020 [31]. Many companies have already faced the threat of insolvency, but others are trying to minimize the risks. The consequence remains the same for all – the responsibility on debt management of legal entities. The Bankruptcy Procedure Code states that joint and several liability of the company's management arises if the business is threatened with insolvency (Part 6 of Article 34 of the Bankruptcy Procedure Code).

The new Law stipulates that temporarily, for the period of quarantine established by the Cabinet of Ministers of Ukraine in order to prevent the spread of coronavirus COVID-19, and for 90 days from the date of the quarantine suspension:

- it is not allowed to open bankruptcy proceedings against debtors-legal entities at the request of creditors on claims against the debtor, which arose from March 12, 2020;

- the period specified in part six of Article 34 of the Bankruptcy Code is extended if the debtor proves that the inability to comply with the one-month deadline for filing for bankruptcy was caused by the spread of coronavirus COVID-19 and/or measures to combat the spread of this disease;

**Bankrupt enterprises in Ukraine in 2016–2019
(Distribution by months)**

Month	2016	2017	2018	2019	Deviations between 2019 and 2016
January	161	141	63	58	-103
February	169	245	57	40	-129
March	144	141	79	59	-85
April	138	107	69	71	-67
May	110	90	85	87	-23
June	133	101	79	60	-73
July	110	131	75	69	-41
August	100	71	61	37	-63
September	113	72	60	70	-43
October	107	79	79	103	-4
November	131	65	85	22	-109
December	148	92	57	42	-106
Total number	1524	1312	833	703	-821

Source: built according to [10]

– the creditors’ committee and the secured creditor (in respect of the property that is the subject of the security) have the right to decide to suspend the auctions for the sale of the debtor’s property. If the creditors’ committee and/or the secured creditor (regarding the property that is the subject of collateral) makes such a decision, the costs of preserving and maintaining the bankrupt’s property and all risks of losing or reducing its value are borne by creditors who made such a decision;

– the accrual of interest on the debtor’s liabilities to creditors who have been restructured by a plan to rehabilitate or restructure the debtor’s debts is stopped. Penalties for non-performance of such obligations by the debtor are not accrued. Overdue liabilities provided for in the debtor’s debt rehabilitation or restructuring plan shall be deferred for the duration of the debtor’s debt rehabilitation or restructuring plan.

Usually, small businesses, such as the company under study, begin to suffer financial losses for 2-3 months of financial crisis. Small businesses have suffered heavy losses as a result of the introduction of quarantine as a result of COVID-19. Thus, according to the Union of Ukrainian Entrepreneurs of

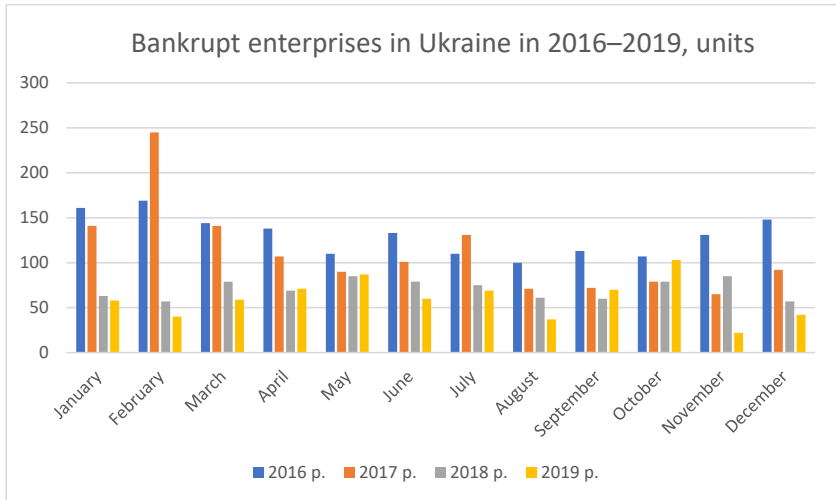

Figure 3. Changes in bankrupt enterprises in Ukraine

Source: built by the author on the basis of Table 6 data

Ukraine, about 6% of small businesses went bankrupt and closed their businesses during critical March 2020, which was a huge problem for the state. One third of business owners (mostly micro-) report a 90-100% drop in revenues in March-April 2020. The same entrepreneurs have already laid off up to 50% of the staff. Small and medium-sized business owners state a 25-50% decrease in income compared to the pre-quarantine period and have already laid off 10 to 25% of employees. For comparison, the loss of profits of large enterprises is 10-25%, there is a projected reduction in staff by 25% by the end of the restrictive measures.

In addition, there was an additional burden on the state in terms of social benefits and the criminogenic situation worsened due to the fact that many citizens found themselves without income [24].

5. Assessing the changes of export-import operations of Ukraine and forecasting in a global pandemic

Modern world society is characterized by strengthening cooperation between countries. The trend towards unification is exacerbated by the need

to address the global challenges facing humanity. The deepest basis for consolidating the integrity of the world is the interdependence of countries in the economic sphere. No country in the world can fully exist if it is not a full part of world economic relations. Today, there are two ways to globalize the world: through intergovernmental economic unions and through the World Trade Organization (WTO).

The most important feature of the development of the modern world economy is the internationalization of production, the growth of economic interdependence of states, the transition of civilized countries from closed national economies to open economies. One of the forms of openness is international economic integration, which can be considered as the highest form of internationalization in the economy.

In the article by Golubova G. V. it is noted that for the analysis of export-import operations it is expedient to use the coefficient of dependence of the country's economy on imports [19, p. 89–91]. And in the study Krasnoded T. L. it was noted that the coefficient of export coverage by imports is also an important indicator for the analysis [21, p. 32–35].

Since 2016, Ukraine has had certain problems with the balance of foreign trade (the difference between exports and imports), the value of which is often negative, indicating a higher value of goods and services that our country imports compared to their exports (Figure 4).

Let's calculate the econometric model of GDP dependence on exports and imports of Ukraine according to statistical data for 2010–2020.

In the process of identifying correlation and regression relationships between the performance indicator and factor values, multiple regression coefficient, coefficient of determination, standard error, Student's t-test was calculated in addition to building an economic-mathematical model, which is graphically shown in Tables 7, 8, 9 [27].

Table 7

Regression statistics indicators

Regression statistics indicators	
Multiple regression coefficient R	0.980939
Coefficient of determination R ²	0.962241
Normalized coefficient of determination R ²	0.952802
Standard error	247962.6

Source: calculated by the author based on Table 10 data

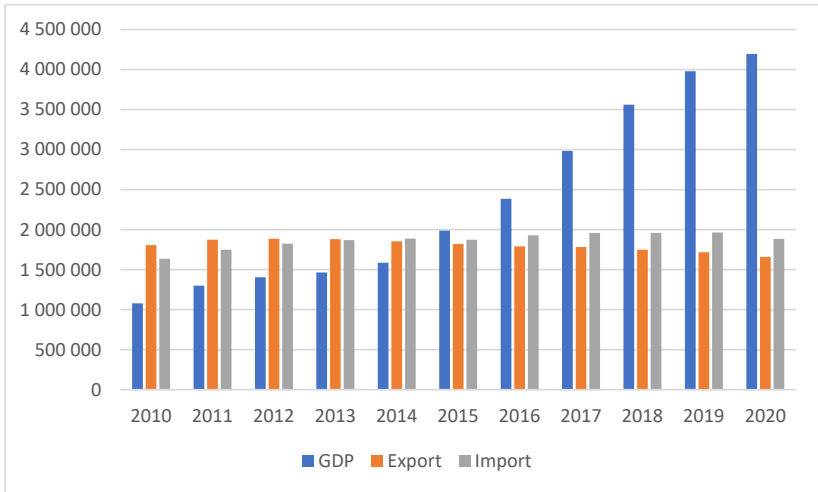

Figure 4. Dependence of Ukraine's nominal GDP on exports of goods and services

Source: built by the author on the basis of Table 10 data

The multiple regression coefficient $R = 0.981$ indicates a very close relationship between the performance indicator and the factor values. Regarding the value of the coefficient of determination R^2 of the obtained correlation and regression model $R^2 = 0.962$, the dependence of gross domestic product by 96.2% is due to the cost of export and import operations. The remaining 3.8% are due to other factors that affect the volume of gross domestic product, but are not included in the regression model.

Table 8

Indicators that characterize the reliability of the regression model

	Df	SS	MS	F	Meaningfulness of F
Regression	2	1.25E+13	6.27E+12	101.9357	2.03E-06
Balance	8	4.92E+11	6.15E+10		
Total	10	1.3E+13			

Source: calculated by the author based on Table 10 data

Given the high values of the multiple regression and determination coefficients, this dependence is quite natural. The variance coefficient, significance of F and F-statistics indicator demonstrates a sufficient level of reliability of the evaluation results.

Meanwhile, to ensure the significance of the regression coefficients, the fulfillment of the condition according to which $t > t_{\text{CRIT}}$ was checked, and as a result the regression coefficient is significant.

Table 6 data show the following: t for Y – intersection and regression coefficients of factor values X_1 , X_2 reflect equal values.

The critical value of t_{CRIT} according to the established level of significance is $\alpha = 0.05$, determined using statistical tables of Student's distribution. The result of the calculation of the critical value is equal to $t_{\text{CRIT}} = 2,228$. Hence, the condition $t > t_{\text{CRIT}}$ is satisfied for all coefficients. Therefore, all coefficients of the model are statistically significant.

Therefore, the data in Table 6, allow to obtain the following regression equation:

$$Y = 15374863 - 11,89 * X_1 + 4,51 * X_2 \quad (1)$$

where factor-argument X_1 – exports of goods and services, X_2 – imports of goods and services, Y – GDP.

Thus, the content of factors not taken into account in the model is estimated to be UAH 15374863 million. Parameter a_1 shows the following: if the volume of exports increases by UAH 1 million, the gross domestic product will decrease by UAH 11.89 million provided that other factors remain unchanged. If the volume of imports is increased by UAH 1 million, the gross domestic product will increase by UAH 4.51 million provided that other factors remain unchanged.

One of the indicators of the balance of foreign trade is the level of import dependence of the country's economy:

$$K_1 = \frac{Imp}{GDP} \quad (2)$$

where Imp is imports, GDP is gross domestic product.

If this figure is less than 0.15 (or 15% as a percentage), then such transactions are quite safe.

The indicator of export coverage by imports, which is defined as the ratio of export earnings to import costs is also very important (can be measured as a percentage):

Table 9

Table of correlation coefficients

Indicators	Coefficients	Standard error	Student's t-test	P-value
Y-intersection	15374863	3158982	4.86703	0.001245
export	-11.8904	1.19116	-9.98217	8.6E-06
import	4.504582	0.857632	5.252346	0.000772

Source: calculated by the author based on Table 10 data

$$K_1 = \frac{Ex}{Imn} \quad (3)$$

de Ex is export.

Therefore, further research includes the calculation and analysis of these indicators (Table 10).

The lowest values of the import dependence ratio (less than 0.5) are observed in 2019 and 2020. The highest level is 1.51, in 2010 and more than one from 2010 to 2014. Note, that this ratio became lower in 2019 compared to the previous year (0.55 to 0.49). Although the whole period under study shows a tendency to maintain Ukraine's import dependence.

Table 10

Ukraine's foreign trade balance

Years	GDP	Export	Import	Import dependence coefficient	Export-import coverage ratio
2010	1 079 346	1 805 869	1635486	1.515256	1.104179
2011	1 299 991	1 873 475	1749041	1.345425	1.071144
2012	1 404 669	1 885 625	1824495	1.298879	1.033505
2013	1 465 198	1 881 041	1869365	1.275845	1.006246
2014	1 586 915	1 854 068	1886968	1.189079	0.982565
2015	1 988 544	1 820 935	1874511	0.942655	0.971419
2016	2 385 367	1 791 525	1928161	0.808329	0.929137
2017	2 983 882	1 782 913	1959506	0.656697	0.909879
2018	3 560 596	1 749 396	1958642	0.550088	0.893168
2019	3 978 400	1 718 528	1964242	0.493727	0.874906
2020	4 194 102	1 659 413	1885054	0.449454	0.8803

Source: calculated by the author based on [36] data

Similarly, the values of the export-import coverage ratio reflect the imbalance of foreign economic activity carried out by Ukraine. They are less than one since 2014. Thus, only in 2010–2014 the value of exports of goods and services exceeded the value of their imports. Please note, that the lowest value of the export-import coverage ratio, equal to 0.87, is observed in 2019, and in 2020 the figure slightly increased.

Thus, during 2014–2020 there is an inverse, unfavorable for Ukraine trend of lower value of exports of goods and services compared to their imports. Please specify, that the best values of indicators do not always coincide.

The impact of COVID-19 and the corresponding restrictive measures of countries in international trade is negative for the improvement of Ukraine's foreign trade balance. Ukraine also has high levels of corruption and inefficient governance, which is not conducive to effective international trade. In connection with the above data, Ukraine needs to work hard to increase export operations, obtain a positive balance of payments, along with reducing misuse and inefficiency of money and eliminate corruption, using and implementing innovative methods of production and management, making optimal management decisions.

Graphs of dependence of exports and imports on the number of the period are shown in Figure 5, 6.

Thus, for exports, the best approximation is a second-order polynomial, the determination coefficient is almost 93%, as well as for imports, the determination coefficient is 94%.

The predicted values are shown in Tables 11 and 12.

The changes of foreign trade turnover is significantly affected by seasonal fluctuations in export-import supplies. Seasonal fluctuations are characterized by relatively stable changes in supply volumes over intra-annual periods over a number of years, i.e. ups and downs of exports (imports) from year to year in certain months (quarters).

Seasonality is referred to as a steady trend of variation in the levels of the time series within the year by seasons. In practice, the identification and forecasting of seasonal components of the changes of export indicators are quite difficult.

To study seasonality, statistical methods are widely used, which make it possible to measure the intensity of seasonal fluctuations of the annual cycle over several years with the help of special indicators – seasonality

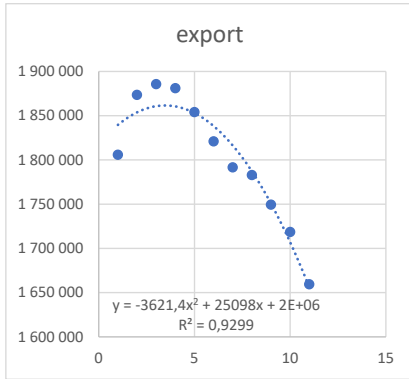

Figure 5

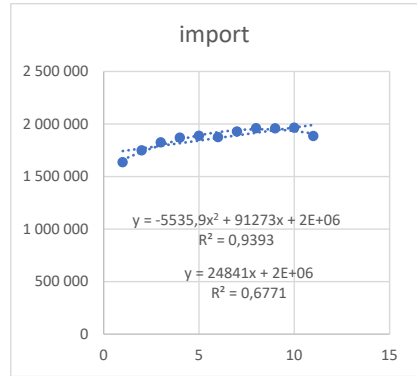

Figure 6

indices; establish the configuration of the seasonal wave and predict possible changes for the future taking into account seasonality. Methods of their calculation depend on the availability of the main trend in the series of time changes.

If the trend in the series of time changes is not available or insignificant, the seasonality indices are found by the formula:

Table 11

Export forecast, UAH million

Period	Model	Determination coefficient	Forecast
2021	$y = -3621.4x^2 + 25098x + 2E+06$	$R^2 = 0.9299$	1779694.4
2022	$y = -3621.4x^2 + 25098x + 2E+06$	$R^2 = 0.9299$	1714257.4
2023	$y = -3621.4x^2 + 25098x + 2E+06$	$R^2 = 0.9299$	1641577.6

Source: calculated by the author based on Table 10 data

Table 12

Import forecast, UAH million

Period	Model	Determination coefficient	Forecast
2021	$y = -5535.9x^2 + 91273x + 2E+06$	$R^2 = 0.9393$	2298106
2022	$y = -5535.9x^2 + 91273x + 2E+06$	$R^2 = 0.9393$	2250982
2023	$y = -5535.9x^2 + 91273x + 2E+06$	$R^2 = 0.9393$	2192786

Source: calculated by the author based on Table 10 data

Table 13
Forecast of exports and imports taking into account seasonal fluctuations

Quarter of the year	Export				Import			
	Seasonality index	Forecast for 2021	Forecast for 2022	Forecast for 2023	Seasonality index	Forecast for 2021	Forecast for 2022	Forecast for 2023
1	0.95	424297.9	408697	391369.4	0.91	522435.2	511722.2	498492,3
2	0.98	436368.2	420323.5	402503	0.90	517929.1	507308.6	494192,7
3	1.07	476470.4	458951.2	439493	1.05	601321.8	588991.2	573763,6
4	0.99	442557.9	426285.6	408212.3	1.14	656420.3	642959.9	626337
Year forecast	1779694	1714257	1641578	Year forecast	2298106	2250982	2192786	

Source: calculated by the author

$$I_c = \frac{\bar{y}_i}{\bar{y}} \cdot 100\% \quad (3.7)$$

where I_c is the seasonality index,

\bar{y}_i is the average level of the series of time changes for the time interval t (quarter, month),

\bar{y} is the general average level of the series of time changes for the year.

Seasonality indices, calculated according to this method, allow to distribute the volume of exports (imports) forecasted for the next year, by seasons in the middle of the year.

Let's determine the forecast of exports and imports and, taking into account seasonal fluctuations, determine their values for each quarter of 2021–2023.

The largest volume of exports falls on the third quarter, while the largest volume of imports was in the fourth.

As a result of the study, based on the analysis of the changes of exports, imports and gross domestic product of Ukraine during 2010–2020, it was found that exports and imports of goods and services have a general tendency to decrease.

Gross domestic product is closely related to these

indicators, so further research should be directed to the development and implementation of economic and political solutions to increase exports of Ukrainian goods and services, reduce import dependence.

6. Conclusions

After analyzing the work of some scientists and conducting our own research, we agree with the conclusion that we can identify the following actions for companies developing in adverse conditions that can reduce the risk of bankruptcy:

1) Strategic management in a crisis plays a paramount role. In a dynamically changing environment, it is the most important factor in the sustainability and development of the enterprise. The effectiveness of the strategy is determined by the relevant internal parameters of the enterprise, its position in the market and in the external environment in general.

2) Management of the enterprise in a crisis is due to rapid response and ability to predict the situation, quickly finding the problems that need to be solved. The creation of special units of analysts will give the head the necessary information to make adequate financial and economic decisions.

3) The speed and quality of information transfer, orders affect the speed of response and implementation of changes in the enterprise.

4) Formation of the company's budget. Cost planning and the transfer of cost management powers to department managers will significantly reduce the overall costs of the enterprise.

5) Suspension for some time or closing long-term investment projects [32, p. 131].

Thus, the bankruptcy of a company is a process related to an issue that still has many unexplored aspects. The existence of a large number of opinions on the definition of the correct interpretation of the concept of "bankruptcy" contributes to the emergence of various methods of its diagnosis. It can also be concluded that bankruptcy has both positive and negative consequences for enterprises, so it is advisable to constantly monitor the likelihood of bankruptcy of enterprises to avoid negative consequences.

One of the main tasks of management in a competitive market environment is to identify the threat of bankruptcy and develop countermeasures aimed at overcoming negative trends in enterprise development. Therefore, today it will be appropriate for businesses to analyze the terms of contracts with

respect to liability for default and the grounds for release from them in case of force majeure, as well as try to settle relations with the counterparty by amending the contract to postpone obligations. This will allow to solve the problem of contract implementation as soon as possible and direct the company's resources to other important areas of activity [7].

In times of economic crisis, you need to be very careful about the concept of “threat of insolvency” – a circumstance that confirms that in the near future the debtor will not be able to meet monetary obligations or make regular current payments. If such signs are found, it is necessary to immediately agree with your counterparties on deferral or installment payment of the debt. If no agreement is reached, you must immediately apply to the court to initiate bankruptcy proceedings.

In these difficult times, it is important to understand that bankruptcy is not the end of a business. Today, there is a generally loyal system for debtors: First, a moratorium is imposed on the forced recovery of debts that arose before the initiation of bankruptcy proceedings. Such arrears are repaid exclusively within the framework of a bankruptcy case with the participation of a qualified arbitration trustee, who will help to find a compromise with creditors and under the control of the court. Secondly, the economic activity of the enterprise still continues, employees are not fired, new contracts can be concluded and work continues to be performed under previously concluded contracts. Third, the seizure of the debtor's property or other restrictions on the debtor's disposal of the property belonging to him may be applied only by the commercial court in the bankruptcy proceedings. Fourth, the commercial court may, at the request of the property manager, lift the seizure of the debtor's property or other restrictions on the disposal of his property, if such arrests or restrictions hinder the debtor's business and restore its solvency. Fifth, transactions unfavorable to the debtor may be declared invalid, and the property alienated under these agreements – returned to the ownership of the debtor [24].

In a pandemic, businesses need to respond quickly to environmental conditions. Risks arising from quarantine measures need to be minimized immediately. This is achieved by creating an effective early warning and response system in the enterprise. However, it should be remembered that postponing the repayment of the debt will be a better choice for the lender than to go into bankruptcy for an indefinite period of time with the

prospect of getting nothing in the liquidation procedure, except the costs of bankruptcy proceedings.

The analysis of changes of export, import, gross domestic product of Ukraine during 2010–2020 were considered. It was found that the balance of foreign economic transactions, in particular the value of exports of goods and services, has a significant impact on Ukraine's gross domestic product. An adequate econometric model of GDP dependence on exports and imports of Ukraine was built. (Determination coefficient is 0.963). It is substantiated that with the increase in exports by UAH 1 million gross domestic product will decrease by UAH 11.89 million provided that other factors remain unchanged. If the volume of imports is increased by UAH 1 million, the gross domestic product will increase by UAH 4.51 million provided that other factors remain unchanged. The values of the coefficients of import dependence and export coverage of imports were analyzed and it was noted that these indicators significantly exceed the allowable level during almost the entire study period. The negative balance of export-import operations in 2010–2020 also indicates some imbalances in Ukraine's foreign trade relations.

The lowest values of the import dependence ratio (less than 0.5) were observed in 2019 and 2020. The highest level was 1.51, in 2010 and more than one was from 2010 to 2014. Please note, that this ratio became lower in 2019 compared to the previous year (0.55 to 0.49). Although the whole period under study shows a tendency to retain Ukraine's import dependence.

Similarly, the values of the export-import coverage ratio reflect the imbalance of foreign economic activity carried out by Ukraine. They are less than one since 2014. Thus, only in 2010–2014 the value of exports of goods and services exceeded the value of their imports. Please note, that the lowest value of the export-import coverage ratio, equal to 0.87, was observed in 2019, and in 2020 the figure slightly increased.

Thus, during 2014–2020 there was an inverse, unfavorable for Ukraine trend of lower value of exports of goods and services compared to their imports. Please note, that the best values of indicators do not always coincide.

It was determined that the changes of foreign trade turnover were significantly affected by seasonal fluctuations in export-import supplies. Seasonal fluctuations are characterized by relatively stable changes in supply volumes over intra-annual periods over a number of years, i.e. ups and downs of exports (imports) from year to year in certain months

(quarters). The forecast of exports and imports was determined and taking into account seasonal fluctuations we would determine their values for each quarter of 2021–2023. The largest volume of exports falls on the third quarter, while the largest volume of imports falls on the fourth one.

The impact of COVID-19 and the corresponding restrictive measures of countries in international trade has had negative effect for the improvement of Ukraine's foreign trade balance. It was found that exports and imports of goods, works and services have a general tendency to decrease.

It is proposed to direct further research to the development and implementation of economic and political decisions to increase exports of Ukrainian goods and services and reduce import dependence, through the use and implementation of innovative methods of production and management, making optimal management decisions.

References:

1. Andrushchak Ye. M. (2001). Udoskonalennia instytutu bankrutstva [Improving the Bankruptcy Institute]. *Finansy Ukrainy*, no. 9, pp. 29–37.
2. Bankruptcy-2020. «Chambers Global Guide». Retrieved from: <https://eba.com.ua/bankrutstvo-2020-chambers-global-guide/> (accessed 23 September 2021).
3. Bazilinska O. Ya. (2009). *Finansovyi analiz: teoriia i praktyka: navch. posib.* [Financial analysis: theory and practice: textbook]. Kyiv: TsUL, 328 p.
4. Blank Y. A. (2009). *Upravlenye fynansovoi bezopasnostiu predpriyatiya* [2-e yzd.]. [Enterprise Financial Security Management] [2nd edition]. Kyiv: Elha, 645 p.
5. Boichyk I. M. (2006). *Ekonomika pidpriemstva: navch. posib. 2-he vyd., dop. i pererobl.* [Economics of the enterprise: textbook. 2nd ed., revised and corrected]. Kyiv: Atika, 528 p.
6. Brely R., Maiers S. (2007). *Printsipy korporativnykh finansov* [Principles of Corporate Finance]. Moscow: Olymp-Byznes, 2008 p.
7. Danilov O. D., Paientko T. V. (2011). *Finansy pidpriemstv u zapytanniakh i vidpovidiakh: navchalnyi posibnyk* [Enterprise Finance in Questions and Answers: textbook]. Kyiv: TsUL, 256 p.
8. Efrat R. The Evolution of Bankruptcy Stigma. Theoretical Inquiries in Law. Retrieved from: https://www.researchgate.net/publication/250148303__The_Evolution_of_Bankruptcy_Stigma
9. *Finansovyi menedzhment: navch. posib. dlia stud. vyshchychkh navch. zakladiv* (2013) [Financial Management: Textbook for students Students of higher Higher education Education] / V. V. Krasnova, M. I. Khromov, B. O. Zhniakin ta in.; za zah. red. V. V. Krasnovoi. Donetsk: DonNU, 463 p.
10. Global bank ruptcy report Dun & Bradstreet World wide Network. Retrieved from: <https://www.bisnode.dk/globalassets/danmark/dokumenter/global-bankruptcyreport-2019.pdf>

11. Hospodarskyi kodeks Ukrainy: Zakon Ukrainy vid 16.01.2003 r. no. 436 [Economic Code of Ukraine: Law of Ukraine of January 16, 2003 № 436]. Retrieved from: <http://zakon2.rada.gov.ua/laws/show/436-15>
12. Hrynychutskiy V. I., Karapetian E. T., Pohrishchuk B. V. (2010). *Ekonomika pidpryiemstva: navchalnyi posibnyk* [Business Economics: Textbook]. Kyiv: Tsentri uchbovoi kultury, 304 p.
13. Huk O. V. (2006). Sutnist ta prychny bankrutstv pidpryiemstv [The Essence and Causes of Corporate Bankruptcies]. *Visnyk Natsionalnoho universytetu «Lvivska politehnika». Menedzhment ta pidpryemnytstvo v Ukraini: etapy stanovlennia i problemy rozvytku*, no. 575, pp. 58–64.
14. Iablonska A.S. Diialnist arbitrazhnykh keruiuchykh: normatyvne vrehulivannia ta neobkhidnist zakonodavchoho vdoskonalennia [Activities of Arbitration Trustees: Regulatory Regulation and the Need for Legislative Improvement]. Retrieved from: <http://www.minjust.gov.ua/?do=d&did=4793&sid=comments>
15. Iankovets T. M., Chemiuk Yu. V. (2016). Porivniannia suchasnykh modelei diahnostyky ymovirnosti bankrutstva pidpryiemstva: zakordonnyi ta vitchyzniani dosvid [Comparison of Modern Diagnostics Models of the Enterprise Bankruptcy Probability: Foreign and Domestic Experience]. *Investytzii: praktyka ta dosvid*, no. 20, pp. 58–62.
16. Kodeks Ukrainy z protsedur bankrutstva: Zakon Ukrainy vid 18.10.2018 r. no. 2597-VIII [Code of Ukraine on Bankruptcy Procedures: Law of Ukraine of 18.10.2018 № 2597-VIII]. Retrieved from: <https://zakon.rada.gov.ua/laws/show/2597-19#Text>
17. Kucherenko S. (2013). Normatyvno-pravove rehulivannia bankrutstva pidpryiemstva v ekonomitsi Ukrainy [Statutory Regulation of an Enterprise Bankruptcy in the Economy of Ukraine]. *Visnyk TNEU*, no. 3, pp. 7–13.
18. Lin S. The Empirical Studies of Chinas Enterprise Bankruptcy Law: Problems and Improvements. National Social Science Fund Project. Retrieved from: <https://onlinelibrary.wiley.com/doi/abs/10.1002/iir.1297>
19. Metodichni rekomendatsii NBU shchodo zastosuvannia komertsiiynykh bankamy Zakonu Ukrainy «Pro bankrutstvo» vid 21.07.94 r, no. 23012/105 [Methodological Recommendations of the NBU on the Application of the Law of Ukraine “On Bankruptcy” of 21.07.94 № 23012/105 by Commercial Banks]. Retrieved from: http://zakon2.rada.gov.ua/laws/show/v_105500-944
20. Metodichni rekomendatsii Tsentralnoi spilky spozhyvchykh tovarystv Ukrainy z analizu y otsinky finansovoho stanu pidpryiemstv vid 27.03.2007 r. [Methodical Recommendations of the Central Union of Consumer Societies of Ukraine on the Analysis and Assessment of the Financial Condition of Enterprises of 27.03.2007]. Retrieved from: <http://www.uazakon.com/big/text892/pg1.htm>
21. Moskvina B. (2020). Bankrutstvo yak mekhanizm antykrizovoho upravlinnia pidpryiemstvom [Bankruptcy as a Mechanism of Crisis Management of the Enterprise]. *Visnyk KNTEU*, no. 2, pp. 58–68.
22. Mynchynska I. V. (2020). Otsinka efektyvnosti zakonodavstva pro bankrutstvo v Ukraini: ekonomiko-pravovy aspekt [Assessing the Effectiveness of Bankruptcy Legislation in Ukraine: Economic and Legal Aspects]. *Efektivna ekonomika*, no. 10. Retrieved from: <http://www.economy.nayka.com.ua/?op=1&z=8267>

23. Oleksandrenko I. V., Ishchuk L. I. (2015). Osnovni prychnyny bankrutstva pidpriemstv [Main Reasons for Bankruptcy]. *Ekonomichnyi forum*, no. 2, pp. 222–226.

24. Onovlena protsedura bankrutstva pid chas pandemii COVID 19: perspektyvy ta realii. Yurydychna hazeta onlain [Updated Bankruptcy Proceedings during the COVID-19 Pandemic: Prospects and Realities. Legal Newspaper Online]. Retrieved from: <https://jur-gazeta.com/dumka-eksperta/onovlena-procedura-bankrutstva-pid-chas-pandemiyi-covid19-perspektivi-ta-realiyi.html>

25. Pepa T. V., Fedorova V. O. (2008). Upravlinnia finansovoiu sanatsiieiu pidpriemstv: navch. Posibnyk [Management of Financial Rehabilitation of Enterprises: Textbook]. Kyiv: Tsentr uchbovoi literatury, 440 p.

26. Plastun O. L. (2009). Vyznachennia sutnosti poniattia «bankrutstvo» v suchasni naukovii literaturi [Definition of the Essence of the Concept of “Bankruptcy” in the Modern Scientific Literature]. *Visnyk ZhDTU*, no. 2, pp. 256–261.

27. Pravdiuk N. L., Potapova N. A., Volontyr L. O. (2009). Ekonometriia: navch. posibnyk [Econometrics: Textbook]. Vinnytsia: PP Baliuk, 274 p.

28. Pro provadzhennia u spravakh pro neplatospromozhnist: Rehlament Rady (IeS) № 1346/2000 vid 29.05.2000 r. [On Insolvency Proceedings: Regulation of the EU Council № 1346/2000 of 29.05.2000]. Retrieved from: old.minjust.gov.ua/file/32678.docx

29. Pro vidnovlennia platospromozhnosti borzhnyka abo vyznannia yoho bankrutom: Zakon Ukrainy vid 14.05.1992 r. no. 2343-XII [On the Restoration of the Debtor’s Solvency or Recognition of its Bankruptcy: Law of Ukraine of 14.05.1992 № 2343-XII]. Retrieved from: <http://zakon0.rada.gov.ua/laws/show/2343-12>

30. Pro vnesennia zmin do Zakonu Ukrainy «Pro vidnovlennia platospromozhnosti borzhnyka abo vyznannia yoho bankrutom»: Zakon Ukrainy vid 22.12.2011 r. no. 4212-VI [On Amendments to the Law of Ukraine “On Restoration of Debtor’s Solvency or Recognition of its Bankruptcy”: Law of Ukraine of December 22, 2011 № 4212-VI]. Retrieved from: <http://zakon0.rada.gov.ua/laws/show/4212-17>

31. Pro vnesennia zminy do Kodeksu Ukrainy z protsedur bankrutstva shchodo nedopushchennia zlovzhyvan u sferi bankrutstva na period zdiisnennia zakhodiv, spriamovanykh na zapobihannia vynyknenniu i poshyrenniu koronavirusnoi khvoryby COVID-19: Zakon Ukrainy vid 18.06.2020 r. no. 728-IX [On Amendments to the Code of Ukraine on Bankruptcy Procedures to Prevent Bankruptcy Abuses for the Period of Measures Aimed at Preventing the Occurrence and Propagation of COVID-19 Coronavirus disease Disease: Law of Ukraine of June 18, 2020 № 728-IX]. Retrieved from: <https://zakon.rada.gov.ua/laws/show/728-20#Text>

32. Rudyka V. I., Velykyi Yu. M., Zoma O. D. (2018). Ekonomichna sutnist poniattia «bankrutstvo»: prychnyny vynyknennia ta naslidky na pidpriemstvi [The Economic Essence of the Concept of “bankruptcy”: its Causes and Consequences to the enterprise], no. 18, pp. 127–133. *Infrastruktura rynku*. Retrieved from: http://www.market-infr.od.ua/journals/2018/18_2018_ukr/23.pdf

33. Shmorhun N. P., Holovko I. V. (2006). Finansovy analiz: navch. posibnyk [Financial Analysis: Textbook]. Kyiv: TsNL, 528 p.

34. Skochylas S. (2008). Analiz ymovirnosti bankrutstva pidpriemstva [Analysis of the Enterprise Bankruptcy Probability]. *Ekonomichnyi analiz*, no. 3(19), pp. 232–234.

35. Sukrusheva H. O., Paputsyn V. M. (2017). Prychyny ta naslidky bankrutstva vitchyznianskykh pidpryiemstv u suchasnykh umovakh [Causes and Consequences of Domestic Enterprises Bankruptcy in Modern Conditions]. *Ekonomika i suspilstvo*, no. 9, pp. 682–686.

36. State Statistics Service of Ukraine. Retrieved from: <http://www.ukrstat.gov.ua/>

37. Tereshchenko O. O. (2004). Finansova sanatsiia ta bankrutstvo pidpryiemstv: navch. posibnyk [Financial Rehabilitation and Bankruptcy of Enterprises: textbook]. КННМ: KNEU, 412 p.

38. Tretiak O. (2000). Pro problemu bankrutstva pidpryiemstv [On the Problem of Bankruptcy of Enterprises]. *Ekonomika Ukrainy*, no. 2, pp. 46–50.

39. Tsyvilnyi Kodeks Ukrainy: Zakon Ukrainy vid 16.01.2003 r. no. 435-IV [Civil Code of Ukraine: Law of Ukraine of January 16, 2003 № 435-IV]. Retrieved from: <http://zakon2.rada.gov.ua/laws/show/435-15>

40. Volot O. I., Babykh I. M., Tkachenko O. O. (2015). Bankrutstvo pidpryiemstva: sutnist, ymovirnist ta metody vyznachennia [Bankruptcy of the enterprise: the essence, probability and methods of determination]. *Naukovyi visnyk Polissia*, no. 4(4), pp. 61–67.

41. Volvach B. V. (2018). Pravove rehuliuвання neplatospromozhnosti ta bankrutstva (retrospektyvnyi i porivnialno-pravovyi aspekty) [Legal Regulation of Insolvency and Bankruptcy (Retrospective and Comparative Legal Aspects)]. *Teoriia i praktyka pravoznavstva*, no. 1(13), pp. 1–13.

42. Voronkova T. Ye., Rybalchenko N. P. (2017). Bankrutstvo pidpryiemstva ta shliakhy yoho podolannia [Bankruptcy of the Enterprise and Ways to Overcome it]. *Internauka*, no. 2(24), t. 2, pp. 39–43.

43. Zastosuvannia norm Kodeksu Ukrainy z protsedur bankrutstva. Zbirka naukovykh statei (2019) [Application of the Norms of the Bankruptcy Procedure Code of Ukraine. Collection of Scientific Articles] / Za zahalnoi redaktsiieiu d.iu.n., sudu Verkhovnoho Sudu S. V. Zhukova. Kyiv: Alerta, 216 p.

44. Zywicki T. Bankruptcy. Economics of legal issues, government policy. Retrieved from: <https://www.econlib.org/library/Enc/Bankruptcy.html>

**PECULIARITIES OF FINANCIAL INTERACTION
OF THE BANKING SECTOR OF ECONOMY REGARDING
FINANCIAL SUPPORT OF AGROFORMATIONS
IN THE CONDITIONS OF EUROPEAN INTEGRATION**

Nadiia Hryshchuk¹

DOI: <https://doi.org/10.30525/978-9934-26-193-0-4>

Abstract. In modern conditions of uncertainty, agricultural formations face problems in finding tools for maintaining their positions, ensuring stable, continuous, effective activities. In achieving the efficiency of activities, an important function is performed by the financial support, which plays an exclusive role both in the implementation of operational activities and in the implementation of investments in accordance with the strategy of the development of the agrarian enterprise. Given this, it is necessary in this context to identify the relevance of these problems and their need for theoretical justification and development of proposals for improving and further intensifying the development of different segments of the agricultural sector in Ukraine. Modern realities of the market economy, social transformations in the country and the significant development of international relations give agricultural enterprises the opportunity to significantly expand the range of sources and forms of attracting financial resources. These forms complement each other on the basis of a conceptual approach to ensure their effective functioning. *Goal.* Development of mechanisms for the formation of financial resources of enterprises in the context of their effective functioning on the basis of a conceptual approach, which includes the principles, purpose, objectives and directly the mechanisms for managing the financial security of enterprises. *Method (methodology).* The research used general scientific methods, in particular, a systematic approach, abstract-logical method, including methods of analogy, comparison, induction and deduction, statistical method; methods of analysis and synthesis; comparison method; system-analytical.

¹ Candidate of Economic Sciences,
Senior Lecturer of the Department of Finances, Banking and Insurance,
Vinnytsia National Agrarian University, Ukraine

All these research methods complement each other and together provide an opportunity to comprehensively consider the subject of research. *Results.* The publication explores groups of sources of financial resources. As a result of research on the basis of the conceptual approach constituent elements of the concept of improvement of management of financial maintenance of the enterprises are developed. Its main goal is to: ensure effective management decisions to attract sufficient financial resources to maximize profits and increase the market value of businesses. *The direction of further research is to develop* methods for assessing the effectiveness of financial support for enterprise development.

1. Introduction

Transformation processes that are inevitable for Ukraine in the direction of creating a socially oriented market economy interpret new approaches to financial and economic support of business entities, including the agricultural sector.

The business environment of the agricultural sector has a small scale of activity, flexibility and mobility in the process of production and economic activities, and is significantly influenced by the external environment and is characterized by a fairly high degree of risk. The main factor that ensures the survival of these economic entities is the implementation of effective management, which should be based on priorities and new approaches to financial support for development and socially oriented management through new credit instruments.

Today in the study of this issue it is worth noting the contribution of such scientists as: Ambrosov V. Y., Artemyeva O. O., Rulikovskiy V. S., Matrosova L. M., Ivanyuta V. F., Matviychuk O. Ye., Varchenko O. M. and other scientists, as well as meters of Ukrainian economics: G. Kireitsev, G. Kaletnik, V. Savchuk, A. Dibrova, S. Kvasha, O. Gudz, N. Davydenko, L. Vdovenko.

However, in the study of these issues in the system of Ukraine's economy there are still issues that are insufficiently resolved or not fully resolved. In this context, the urgency of these problems and the need for theoretical justification and development of proposals to improve and further intensify the development of various standardized agricultural enterprises in Ukraine.

2. The current state of financial cooperation of the banking sector of the economy

The purpose of this study is a comprehensive approach and further study of financial security – credit support of agricultural formations, namely farms by diversifying credit instruments, identifying problems with their functioning and justifying the directions of their development in globalization.

According to the set goal, the following tasks are to be solved:

- analyze the theoretical aspects and dynamics of small and medium business development in Ukraine;
- identify the entities that have the greatest impact on the activities of small and medium enterprises in Ukraine;
- identify problems and reasons for slowing down the development of small business in Ukraine and suggest ways to solve them.

The current external challenges facing our country's economy have sharpened the understanding that the foundation of a strong and independent economy is the real sector, which produces material goods and services, which must be provided with adequate support from the financial market, including one of its developed segments – the banking sector.

The results of a number of current studies show that in emerging markets, meeting the needs of the real sector with banking resources is one of the strategic areas of economic development.

The need to ensure further economic growth raises a number of important issues of attracting external financial resources of investment nature into the system of the reproduction process.

Banks play a particularly important role in intensifying investment activities. An important form of participation of banks in the investment process is an investment loan.

In the current conditions of economic development, the interaction of the banking and real sectors of the economy, adaptation and implementation of positive experience of foreign countries that have managed to ensure high rates of economic growth by active participation in this process of the banking sector are very timely.

Note that agriculture can be more productive in terms of increased investment in the agricultural sector, ie as financing from the state are lending to this sector.

The organization of the process is influenced by the sources of financing the production activities of enterprises, which include bank loans.

Let's define the interpretation of the concept of bank lending to the agro-industrial complex, which reflects the provision of enterprises with funding on the terms of return on funds, fixed deadlines, controlling the targeted use of funds, and providing preferential terms for certain industries.

We propose to give the main specifics of agro-industrial loans. It should be noted that as of November 5, 2020, the list of authorized banks that signed the Memorandum with the Ministry of Economy, which includes the implementation of state support for agricultural producers, includes 36 banking institutions.

The most important aspects should be: development and implementation of new mechanisms to support agricultural enterprises with a gradual departure from direct payments to rural development programs.

It is necessary to apply the experience of the world's leading countries in providing direct payments, subsidies, various benefits to farms, taking into account the Ukrainian realities, ie stimulating promising areas of agriculture.

In today's turbulent environment, small business plays an important role in ensuring sustainable economic development and solving social problems at the state, regional and local levels. Due to small business, the market principles of management are successfully developing, local budgets are being filled, and the system of economic relations in various spheres and branches of activity is being actively formed. Compared with other economic entities of the national economic complex, the organization of economic and financial activities of small businesses has a number of features.

The changing economic situation creates new problems for commercial banks in the field of investment lending, which requires timely development and implementation of new and improvement of existing mechanisms that mediate the transformation of credit resources of the banking system into productive investments of the Ukrainian economy.

Small business is an integral part of a market economy. It operates in all countries of the world and covers areas of economic activity not prohibited by law. Differences between small, medium and large businesses are determined on the basis of qualitative and quantitative parameters on the basis of their standardized division (table 1).

Table 1

Criteria for the division of economic entities by standardized division*

Categories by standardized division	Legal entities	Net sales income, euros	Book value of assets, euros
“Great”	annual income > 50 million euros average number of employees > 250 people	> 40 000000	> 20000000
“Medium”	annual income up to 50 million euros average number of employees up to 250 people	to 40,000,000	to 20,000,000
“Small”	annual income up to 10 million euros average number of employees up to 50 people	to 80,000	to 400,000
“Micro”	annual income ≤ 2 million euros average number of employees ≤ 10 people	to 700,000	to 350,000

Note* Grouped by (Agriculture. Official website of the State Statistics Service of Ukraine)

The most significant qualitative feature of such a distinction is the entrepreneur himself. Such an enterprise is considered small, where the entrepreneur himself participates in the production process, performing professional and technical functions, and trade and organizational functions are transferred to members of his family. The combination of three functions in the person of an entrepreneur is especially significant for a small business: an entrepreneur, an investor and a manager. Of course, for the effective functioning of a small business, it is vital to provide sufficient financial resources, which in turn have a distributive nature and are in monetary form. Financial support of reproduction processes in agricultural enterprises is made possible by the availability and use of financial resources.

Agrarian formations play a significant role in the development of productive forces and ensuring food security of the country. Their appearance in the mid-1990s and the increase in numbers so far have shown that the economically active rural population has preferred the organizational and legal form of rural entrepreneurship, legitimized at the legislative level. According to the Law of Ukraine “On Farming” of June 19, 2003 № 973-IV, a farm, as a farm that belongs to small agrarian formations according to the structured division, is a form of entrepreneurial activity of citizens

with the creation of a legal entity wishing to produce goods. agricultural products, engage in their processing and sale in order to make a profit on land provided to them for farming. Commodity peasant economy is a form of organization of agricultural production carried out by labor of family members on the basis of their private property according to the Law on personal peasant economy of 15.05.2003 № 742-IV.

Table 2

**Structure of economic entities of the agricultural sector of Ukraine
in the period of unstable economy (2014–2017)**

Business entities	2014		2015		2016		2017	
	from	%	from	%	from	%	from	%
Business associations	7750	16,8	7721	17,0	8700	18,2	6967	15,3
Private enterprises	3772	8,2	3627	8,0	3752	7,9	3215	7,1
Cooperatives	674	1,4	596	1,3	738	1,5	448	1,0
Farms	33084	69,7	32303	71,2	33682	70,6	34137	74,9
State enterprises	228	0,6	241	0,5	222	0,5	199	0,4
Enterprises of other forms of management	691	3,0	891	2,0	603	1,3	592	1,3
Total	46199	100,0	45379	100,0	47697	100,0	45558	100,0

Source: State Statistics Service of Ukraine

The period of unstable economy is characterized by changes in the political system and economic course of the state. in the total number of enterprises engaged in agricultural activities (table 2).

The period of economic growth is characterized by radical changes in the economic and political field (table 3).

The last two years, 2019 and 2020, give us a clear understanding of the positive economic progress in the field of economic transformation, the results of which are a decentralized division of territorial communities. Such an enlarged division made it possible to consolidate the creation of business associations.

Further positive dynamics in farms is a confirmation of the competitiveness of this form of agricultural entrepreneurship given the relatively higher growth rate than in other agricultural enterprises.

Table 3

**Structure of economic entities of the agricultural sector of Ukraine
in the period of economic growth (2018–2020)**

Business entities	2018		2019		2020	
	from	%	from	%	from	%
Business associations	6814	15,1	120	18,5	10931	23,6
Private enterprises	3887	8,6	3810	7,8	3956	8,1
Cooperatives	496	1,1	758	1,5	485	1,01
Farms	33164	73,5	33164	67,4	32452	66,9
State enterprises	180	0,4	215	0,4	215	0,4
Enterprises of other forms of management	587	1,3	2141	4,4	465	0,9
Total	45128	100,0	49208	100,0	48504	100,0

Source: State Statistics Service of Ukraine

Given the statistics on the dynamics of the number of farms (slight fluctuations in the number of agricultural enterprises and a positive gap between them farms), it can be argued that enterprising peasants and their families are relatively easier to enter agricultural markets by starting commercial production.

Positive changes are also observed in the structure of agricultural production. In 2018, compared to 2014, Ukrainian farms increased their crop production by 32.3 percentage points, which confirms their overall competitiveness in crop production compared to all agricultural enterprises, whose production growth was 18.2 percentage points.

At the same time, livestock farms in 2018 – UAH 1,499.3 million, but since 2014 there has been a significant growth rate – 11.7 percentage points, while all agricultural enterprises produced 33,687, UAH 5 million gross livestock production, and the growth rate of which amounted to 0.5 v.p. (table 4).

Thus, there are outpacing growth rates of livestock and crop production by farms compared to the corresponding indicators of all enterprises. This once again confirms that although agricultural enterprises retain the status of leaders in the production of crop products. The dynamics of statistical indicators indicates a constant trend towards outpacing rates of growth of its production in farms, which confirms the results carried out

The volume of gross output produced by agricultural enterprises and farms of Ukraine, 2014–2018, UAH million

Indexes	2014	2015	2016	2017	2018	2018/2014, +/-
Agricultural enterprises						
Gross output – total, UAH million	139058,4	131918,6	145119,0	140535,2	158306,5	13,8
crop products	105529,5	99584,7	113392,6	108601,1	124719,0	18,2
livestock products	33528,9	32333,9	31726,4	31934,1	33687,5	0,5
of which farms						
Gross output – total, UAH million	19188,8	17 565,4	22101,4	21743,1	25118,9	30,9
crop products	17847,0	17565,4	20705,3	20338,8	23619,6	32,3
livestock products	1341,8	1343,9	1396,1	1404,3	1499,3	11,7

Source: State Statistics Service of Ukraine

according to the method of analysis, and states the highest reliability (by correlation coefficient). The format of the trend line is linear, the equation $y = 31767x + 2307.3$, the correlation coefficient $R^2 = 0.9949$. The results of the equation are displayed in the selection graph:

Volumes of production of farms (as well as enterprises of the agricultural sector as a whole) indicate a preference in crop production. Livestock farming is developing slowly, but with a steady increase in production volumes, which also reflects their progress in the relevant market.

In the structure of gross agricultural output, the dynamics of the share of gross output produced by Ukrainian farms also shows a steady upward trend: 2014 – 7.6 percentage points, 2015 – 7.9 percentage points, 2016 – 8.7 pp, 2017 – 8.7 pp, 2018 – 9.3 pp.

Compared to 2014, in 2018 it increased by 30.9 percentage points. This indicates a slow but steady increase in the pace of production and sales of agricultural products by farms in the agricultural market of Ukraine.

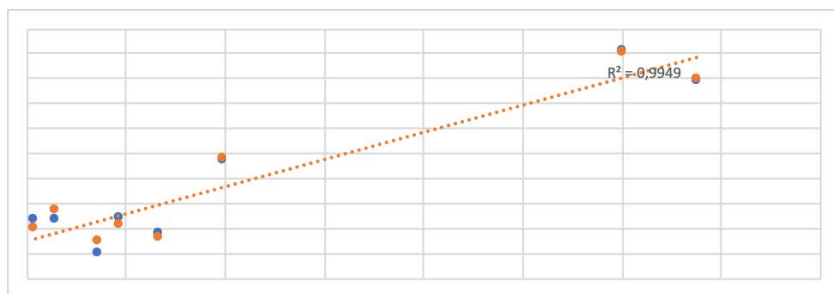

Figure 1. The results of the correlation of production indicators of small agricultural enterprises during 2014–2018

3. Problems of providing finance of agrarian formations

With some reservations, these indicators can be considered as the share of the agricultural market occupied by farms. In 2018, it amounted to 9.3 percentage points, and compared to agricultural enterprises in general (57.0 percentage points) and households (43.0 percentage points) is relatively small, but constantly growing.

In our opinion, it also reflects the problems of reliability of relevant statistics, as the calculation of gross output of households is based on unrepresentative data on conditional (attributed to them) production in homesteads, without taking into account the relatively low level of productivity, marketability and average sales prices, agricultural enterprises.

Given the above, it can be argued that the gradually growing share of farms in production in general indicates their importance and continued competitiveness in agricultural markets, even given the imperfect institutional framework of various groups of producers, which may contribute to its underestimation.

Therefore, today the state provides at least 8 programs to support farming. One of them is the program of interest compensation on loans. During the program (as of June 1, 2019) 154 agrarians-clients of Oschadbank applied for such compensation. Some of them (80%) received loans for the purchase of machinery and equipment. The remaining 20% of applications were for compensation for working capital loans.

Financial support is provided exclusively to farms that own or use agricultural land. In 2019, the requirements for compensation recipients were simplified, in particular, restrictions on the size of the land fund in ownership and / or use were lifted, and the maximum amount of revenue from sales for the last year was increased to UAH 20 million.

According to T. Vysotsky, the main criteria are the same for all borrowers – the experience of doing business for farmers for at least two marketing years and a positive credit history. The recipient can benefit from compensation for no more than one short-term and one medium-term loan during the program period (there can be two parallel applications). To receive compensation from the budget, applications must be submitted to the bank by December 1 of this year, and the register for interest compensation in December will be submitted by the bank to the Ministry of Agrarian Policy by February 10 of the following year.

Partial reimbursement of costs associated with agricultural services, financial support for agricultural service cooperatives, cheaper loans, additional financial support for family farms is a timely and effective message of developing the competitiveness of small agricultural formations.

It is also significant that as of 2020, 71,573.2 thousand hryvnias of state support was received from farms. The corresponding distribution of funds was approved under the budget program “Financial support for agricultural producers” in the area of “Financial support for the development of farms” in the following areas:

- providing partial compensation for the cost of purchased agricultural machinery and equipment of domestic production for 2019 in the total amount of UAH 24,400.5 thousand. The funds will be received by 460 farms that have purchased 1,152 units of equipment.

- providing partial compensation for the cost of seeds of agricultural plants of domestic production, purchased from individuals – entrepreneurs and legal entities engaged in production and/or its implementation in 2019 for a total amount of UAH 8,537.5 thousand. The funds will be received by 447 farms that purchased 3,368.4 tons of seeds.

- provision of a budget subsidy per unit of cultivated land (1 hectare) – to newly established farms – for October-November 2019 in the total amount of UAH 12,643.2 thousand. The funds will be received by 225 newly established farms;

Chapter «Economic sciences»

– providing a budget subsidy per unit of cultivated land (1 hectare) – to other farms in October-November 2019 in the total amount of UAH 25,992.0 thousand. 861 farms will receive the funds.

For 2021, the Government has prepared a program to support the development of farms in the following areas:

- budget subsidy for keeping cows;
- surcharge in favor of insured persons – members / chairman of the SFG without acquiring the status of a legal entity of SSC;
- partial reimbursement of costs related to the provision of agricultural advisory services;
- budget subsidy per unit of cultivated land (1 hectare) – to newly established farms;
- financial support on a revolving basis.

You can also get compensation for domestic agricultural machinery.

Partial compensation of the cost of purchased agricultural machinery and equipment of domestic production is provided to farms on a non-refundable basis in the amount of 40% of the cost of purchased machinery and equipment excluding VAT specified in the acceptance certificate and other documents confirming payment through the state bank.

Under the budget program “Financial support for agricultural producers” support is distributed:

- in the area of “Partial compensation for the cost of agricultural machinery and equipment of domestic production” in the amount of 25% of the cost;
- in the area of “Financial support for the development of farms” in the amount of 15% of the cost.

Also, one of the important areas of state support is cheaper agricultural loans.

According to the results of the year, according to the approved orders and submitted registers of recipients of budget funds, the Ministry of Economy actually sent funds to authorized banks in the amount of UAH 1,047.7 million or 99.9% of the planned ones, which were transferred to current accounts. borrowers.

More than 4,200 borrowers who applied to authorized banks received targeted budget funds.

The total amount of loans raised by such entities was over UAH 143.5 billion, of which UAH 24.8 billion was compensated at the expense of budget funds, including:

a) by type of loan:

- short-term – UAH 11.6 billion (46.7%);
- medium-term – UAH 6.1 billion (24.7%);
- long-term – UAH 7.1 billion (28.6%);

b) by type of activity of borrowers:

- livestock industry – UAH 4.5 billion (18%);
- other industries – UAH 20.3 billion (82%).

The average interest rates of banks, at which agribusiness entities attracted loans, were 18-22% per annum.

Compensation is provided to recipients for accrued and paid in the current year interest on loans in the amount of 1.5 discount rate of the National Bank, effective on the date of accrual of interest, but not more than the amount of the loan agreement reduced by 1 percentage point.

Interest rates on the loan are subject to compensation:

- involved in one year, the amount of which does not exceed 500 thousand. UAH to cover production costs;
- involved up to 3 years, the amount of which does not exceed UAH 9 million, for the purchase of fixed assets for agricultural production, the implementation of costs associated with the construction and reconstruction of agricultural production facilities.

To receive compensation you must:

- Do not have bankruptcy cases, do not go bankrupt, do not be in liquidation.
- Do not have arrears of more than 6 months to the state budget, the Pension Fund and the funds of the obligatory state social insurance.
- Do not submit documents for compensation under concluded credit agreements, the interest for the use of which is reduced with the help of funds provided for other government programs.

Agricultural compensation is provided to agribusiness entities (legal entities and natural persons – entrepreneurs) for all types of agricultural activities.

The amount of compensation is 1.5 of the discount rate of the National Bank, effective on the date of accrual of interest, but not higher than the

amount provided for in the loan agreements and reduced by 5 percentage points.

For one business entity provides a limit of 5 million UAH.

In addition to the state program to reduce the cost of loans, there is a program provided by “PrivatBank”, called “AgroCube”.

The interest rate on this program is 1.6% per month of the loan amount – the first 6 months and 1.4% per month of the loan amount – the next 6 months.

The loan amount is from 50,000 thousand UAH up to UAH 1,000,000 million.

Funds are credited to the current account of the entrepreneur in “PrivatBank”.

The loan is repaid monthly in equal installments. Possible repayment procedure for clients in the field of agribusiness (“AgroCUB”):

1. The first 6 months only interest is repaid, the remaining 6 months the amount of debt with interest equal parts.

2. The client chooses the desired 6 months to repay the loan, starting from the next month of the loan.

In general, the experience of bank lending to agricultural enterprises shows that the current process of lending to agricultural enterprises by commercial banks is still quite complicated, and requires companies to have a large number of necessary documents and their lengthy consideration.

In addition, banking institutions prefer to finance large agricultural producers, which is due to the following reasons:

- the presence of organized financial reporting in large companies;
- availability of sufficient and modern collateral for loans;
- diversification of activities of large enterprises, which can compensate for possible losses in one of the activities;
- ignorance and lack of technologies for financial analysis of agricultural enterprises;
- insufficient specialists to work with small agricultural enterprises (it is more profitable for banks to issue large loans at relatively lower labor costs), etc.

Thus, small and medium-sized agricultural producers in Ukraine have insufficient access to bank lending.

It should also be noted that the agricultural sector at the end of the reporting year 2020 mastered 4.665 billion UAH of state subsidies from the budget. Budget grants were distributed in 11 basic areas:

Nadiia Hryshchuk

- development of animal husbandry and processing of agricultural products (UAH 1.6 billion);
- development of farming (UAH 120.8 million);
- compensation for the cost of equipment (UAH 991.4 million);
- compensation for the cost of loans (UAH 1.2 billion);
- development of horticulture, viticulture and hop growing (UAH 512 million);
- compensation for lost crops (UAH 108 million);
- development of niche crops (UAH 50 million);
- development of potato growing (UAH 53 million);
- development of irrigation (UAH 16.7 million);
- compensation of SDRs (UAH 0.6 million).
- compensation to buckwheat producers (UAH 50 million).

In 2021, state support for farmers amounted to more than 4.6 billion UAH, taking into account the relevant changes that were made to the budget.

But 2021 has shown that today the demands of farmers are much higher than the amount of support. The total need, which Ukrainian farmers formed by submitting documents, amounted to almost UAH 7 billion.

UAH 6.5 billion was planned for 2021. UAH 4.7 billion was actually used:

Financial support for agricultural producers – UAH 4.66 billion.

Provision of loans to farms (UDF) – UAH 50 million.

In 2019, the state planned UAH 6.9 billion.

UAH 4.6 billion actually used.

Distribution of funds for agricultural assistance programs by industry:

State support of the livestock industry – UAH 2.4 billion;

Financial support for agricultural producers – UAH 641 million;

Financial support for measures in the agro-industrial complex by reducing the cost of loans – UAH 449 million;

Financial support for the development of farms – UAH 420 million;

State support for the development of hop growing, establishment of young orchards, vineyards and berries – UAH 397 million;

Providing loans to farms – UAH 225 million.

4. Ways of further financial cooperation of the banking sector of the economy to ensure agricultural formations

For 2022, processing, animal husbandry, horticulture and land reclamation will remain a priority, as these areas create the largest number of jobs. They are the most capital-intensive in terms of value added.

In addition, the focus will be on a new area – agricultural insurance. It will help farmers to be more confident in their activities, despite natural and financial difficulties.

Another new area of state support – land reclamation – has already made it possible to launch pilot projects in various areas and will be scaled up after the launch of the association of water users in 2022. Financial support for state support remains at the level of 2021, but this is not enough. At the government level, there is a common position that support should be increased in the first half of 2022, as the agricultural sector today gives the largest increase in catches of the country's domestic product.

The government will also work to expand affordable lending to farmers, which should reach at least UAH 100 billion.

The draft State Budget for 2022 provides UAH 8 billion for the development of the agro-industrial complex + UAH 301 million for the 2021 plan. In 2022, within the limits of the funds we have in the amount of UAH 4.5 billion, and this is due to the level of the government and the head of state, the expansion of state support is envisaged, primarily in the direction of animal husbandry.

Thus, private farmers will have additional opportunities to expand their farms. Increasing the role of the state in the agricultural sphere will help increase food security and export potential of the country.

That is, it is necessary and important to use a balanced and effective process of reforming the agricultural sector to support innovation, to implement effective water-saving irrigation technologies.

The development of the agricultural sector is influenced accordingly by credit resources, as they ensure the continuity of the processes of investment and inflow, the gap between which is associated with seasonality, which is inherent in most agricultural enterprises. It is in the absence of enterprises' own funds that there is great hope and support for lending by replenishing financial resources.

Among all industries, the agricultural sector has seen an improvement in the formation of new government lending support programs. However, to obtain them, you must comply with separate lists of conditions.

It is very important to note a number of relevant options for supporting the agro-industrial complex, which were developed by the relevant Ministry for 2020.

It is important to note that the development of the agricultural sector of the economy is influenced by the rate of investment, as it is from investment savings and investment in production and technical resources depends on improving agriculture, and, accordingly, investment contributes to increasing the competitiveness of products. In order to develop the most effective innovation potential, there is a need to update the Ukrainian “export-import policy” in the fields of agricultural production and resource processing.

When allocating investments within the state, the priority is given to those industries that are more shown to benefit from investment and, accordingly, have an impact on the economic growth of related industries and industries. These include agriculture and other branches of the agro-industrial complex of Ukraine.

Note that the agro-industrial complex within the state is the main complex on which investment is focused.

According to the indicator received from the Ministry of Economic Development, Trade and Agriculture of Ukraine as of July 1, 2019, Ukraine has already implemented and continues to implement 444 investment projects totaling UAH 40.6 billion, in the previous 2018 this figure amounted to 393 investment projects worth 40.1 billion UAH., ie there is an improvement. However, the main financing for the development of the agro-industrial complex is the use of own funds of the agro-industrial complex.

As one of the main directions of agro-industrial development is competitive development, it is important to note that attracting foreign investment, due to the creation of a free trade zone and investment growth has formed a stable inverse relationship with the growth of mutual trade. It is also important to note that when investing in agricultural activities there is an indirect influence of internal and external factors. According to the internal factors are indicators of yield and productivity of cattle, specialization and

technology of the production process, the level of productivity labor and the formation of the calculation of the cost of production, and, accordingly, the long-term or short-term investment. It is the internal factors of influence that depend on the producer, in contrast to external factors, which include pricing policy, both global and domestic, government support, existing soft loans, seasonality, inflation, and tax base.

It is important to note that external factors influencing investment play a greater role. After conducting all the assessments of capital investment indicators of existing government programs, we propose to identify the main conceptual aspects of the development of the agricultural sector, which include:

- improving the conditions for the development of the agricultural sector, especially with an emphasis on agriculture;
- improve the conditions for providing state financial support to agricultural enterprises;
- development and implementation of housing and communal services to the population of settlements, urban-type settlements, under the conditions of formation of enterprises in order to provide young people with jobs and encourage living in the village;
- improve the conditions for receiving investment deposits;
- increase the competitiveness of agro-industrial products by improving product quality and expanding markets;
- development of effective state support programs in the form of subsidies to support low-income people;
- development of conditions for the development of agro-industrial science and education.

It should be noted that the agricultural sector is one of the main complexes of domestic economic development of the country, which affects the development of the country's export potential, the use of efficient production technologies and resources.

It should be noted that the indicators of agricultural exports are the main part of agricultural exports, which increase with fruitful cooperation with the European Union, Asia and Africa. The main areas of increasing competitiveness in the international market are the timely modernization of the country's economy, effective attraction of imported resources, equipment, and, accordingly, the expansion of a favorable investment climate.

The most common type of investment loan is a bank investment loan. The main criteria that the borrower must meet to obtain an investment loan: stable financial condition; the borrower (experience in attracting this type of funding in the past, staff qualifications); participation with own funds (as a rule, not less than 25%); positive credit history (conscientious fulfillment of obligations to creditors); solvency (based on the forecast of cash flows for the project, as well as the optimal loan repayment schedule).

The terms of the loan to finance investment projects are somewhat different from the usual ones. For example, consider the conditions for granting a loan for business development (investment lending) of small enterprises by leading commercial banks of Ukraine (table 5).

Table 5

**Providing loans by commercial banks
for the development of agribusiness**

Lending conditions	Banks		
	PJSC PrivatBank	PJSC Megabank	JSC Credit Agricole
The purpose of lending	capital expenditures (acquisition / modernization / reconstruction of fixed assets); launching an additional line of business		
Repayment schedule	interest – monthly, loan – according to the terms of the loan agreement, possible receipt postponements	the loan is repaid monthly in equal installments, payment interest monthly	monthly, from the 1st to the 7th day of the month following reporting (in January and May – until the 15th)
Maximum the size of the limit	up to 70% of the cost investment project	up to 75% of the project cost, and up to 85% subject to the provision of additional support	up to 70% of the cost investment project
View financing (issuance form)	term loan or non-revolving credit line according to the contract	non-revolving credit line; funds are provided in non-cash form by transfer from the loan account to the current account of the borrower / counterparty	term loan or non-revolving credit line

The term of investment lending in most banks is 5 years, interest rates are set at about 20% per annum in UAH and above. Thus, in PJSC “PrivatBank” annual rates are: in hryvnia – 21%, in US dollars – from 9.1% in euros – from 8.2%. But the final rate and term of financing is determined depending on the industry in which the project is implemented, the composition of the participants and the degree of responsibility of each of them, the credit history of the company that applied for financing.

A special megatrend is a medium-term loan, ie up to 3 years, which can be used to purchase fixed assets for agricultural production.

This is machinery and equipment without restrictions on the country of manufacture. Compensation also covers loans for the costs associated with the construction and reconstruction of agricultural production facilities. In order to improve the financial support of small agrarian formations, it is necessary to improve communication processes, adapt foreign experience of state support and formulate appropriate state policy. Prospects for further research will be to develop the experience of European countries in the development of the farming movement, as well as agricultural cooperation and methods of determining their financial condition.

Further development of agriculture in Ukraine and agricultural production, in particular, requires significant annual investments. Today, most of them are funded by agricultural enterprises, which does not allow to fully ensure the effectiveness of agrarian reforms and intensify agricultural development. Therefore, it is necessary to increase the volume of investment resources in the agricultural sector at the expense of other sources of funding. The main promising areas for financial support for the development of agricultural enterprises are a set of measures by the state and the banking system, aimed at developing an effective integration mechanism of interaction with the agricultural sector of the economy; increase the amount of financial support for agricultural enterprises through the use of all possible sources to attract capital, including foreign capital. The effectiveness of state financial support to agricultural enterprises can be achieved if budget funds are allocated transparently in projected, pre-informed areas on a permanent long-term basis and in well-defined amounts.

When developing mechanisms for the development of agriculture, it is necessary to take into account the differences and features of each sector of

development, risks specific to a given region, and to develop management methods for each individual entity.

When developing mechanisms for the development of the agricultural sector, it is necessary to take into account the differences and peculiarities of each development sector, the risks inherent in a given region, and to develop management methods for each individual entity.

It should be noted that the agricultural sector needs the introduction of high efficient production technologies, expansion of technical equipment required to increase the productivity of the production process.

Since the development of the sugar and meat and dairy industries depends on this industry, the products of which are used as raw materials for other industries.

Instability and problems in the countryside are a consequence of:

- lack of financial and economic mechanisms;
- lack of support from the state, which includes support for price parity, which affects the development of agricultural producers.

The development of the agro-industrial complex should be based on the optimization of exports of agro-industrial products in accordance with food security requirements.

Note that for the development of the agricultural sector there is a need to develop and implement competitive advantages of the production process of certain products in order to improve the foreign trade balance.

In order to attract more investment, there is a need to encourage better business conditions for foreign investors, reduce the tax burden on the agricultural sector, merge or eliminate inefficient organizations, increase competitiveness, improve training and skills to improve productivity.

Investment attractiveness should be focused on the development of agro-industrial production, but note that there is a dependence on a favorable external environment, the investment climate, which in turn are important factors in attracting investors to the agro-industrial complex. Market-oriented agriculture should have constant access to credit, which can be offered on both price and non-price terms, adapted to its natural, technical, economic and financial characteristics.

Although all the loans known today are important for farms, long-term instruments are of particular importance. The latter, in turn, are difficult to generate in traditional banking, which is usually financed with short-

and medium-term capital. This type of mismatch between the liabilities and assets of lending banks has been and remains one of the reasons for the involvement of public authorities in the field of agricultural lending. Forms of intervention can be different, as well as the assessment of its effectiveness, and this is a topical and topical issue that requires in-depth study.

To answer the question, we consider the NBU data on loans granted and interest rates on them for 2020 and 2019, where we can say about some changes. Thus, UAH 44 billion (46%) increased lending to agriculture. The 5-7-9 program helped a lot here. Agricultural enterprises were its main beneficiaries and under the program were able to refinance previous loans at 0%. Refinancing of previous loans amounted to 62% of UAH 17.4 billion issued in 2020 under the program, the share of loans with a term of more than 1 year increased from 8% in 2019 and 17% in 2020. Perhaps the banks chose only the “best” borrowers in the industry.

Interest rates in some sectors have hardly been adjusted. An example is the agricultural construction sector – the rate for it even increased slightly compared to 2019 – from 16.4% to 16.9% – while for other sectors loans became cheaper. As the total amount of lending is very small (less than 1% of loans issued), it may be that one or more borrowers have had such an impact. In March 2020, the National Bank of Ukraine introduced long-term refinancing (for up to 5 years). Such a mechanism was to support bank lending by enhancing the effect of other measures, such as lowering the discount rate up to 6% per annum and the introduction of incentive reserve requirements. These changes have given some impetus to lending to non-financial corporations for more than a year. After a decrease in April-May, from July 2020 the volume of loans lasting more than a year exceeded the volume of such loans issued in the respective months of 2019 (as evidenced by the data of the National Bank of Ukraine).

Risks and non-transparency of business are not only an obstacle for non-traditional monetary instruments, but also limit the effectiveness of further reduction of the discount rate. Therefore, monetary easing alone is not enough to further reduce the cost of lending.

We agree that measures need to be implemented that will reduce another component of the rate – credit risk. These are primarily measures aimed at improving the quality of institutions in Ukraine – building an effective judicial system for effective protection of property rights. As well as

reducing political interference in agrarian business and corruption. In the current environment, borrowers' risks remain high, including through non-transparent or "optimized" financial reporting. Perhaps that is why more than 60% of loans under the 5-7-9 program are refinancing loans, ie they have been obtained by companies with a credit history.

Today, within the framework of the decision "Affordable loans 5-7-9%" it is possible for farmers to take an anti-crisis loan to replenish working capital or refinance a previously obtained business loan. But there are things that need to be improved to make this program more effective. The first step is the differentiation of interest rates. However, it should be noted that the program "Affordable Loans 5-7-9%" does not provide for the differentiation of interest rates by maturity, although in Ukraine there is a significant difference between short-term and long-term interest rates.

This, in particular, restrains lending in the long-term segment, where these rates are higher. Instead, the program provides several differentiated levels of the final interest rate for the borrower, depending on the purpose of the loan and the amount of annual income. We can state that at the same time the lowest final rate – 0% per annum for loans to refinance existing loans – does not stimulate new lending. But at the same time, it forces banks to join the program to avoid losing customers by refinancing their loans with other participating banks.

In July 2020, the EU and Ukraine signed three new € 105 million financing agreements to support Ukrainian, agricultural and small-scale agricultural development, as well as the Ukrainian authorities in implementing key reforms. The agreement also aims to mitigate the socio-economic consequences of the coronavirus pandemic and continue to support the health sector. Support for agriculture and the development of small agricultural enterprises will be provided by EUR 25 million, which will improve access to loans for small agricultural enterprises throughout Ukraine under the EU4Business program and the approximation of Ukrainian legislation to EU legislation in accordance with AA / DCFTA.

Another 20 million from the recently signed agreement is intended to improve the business / business environment through the harmonization of Ukrainian and EU legislation, access to credit for modernization of enterprises, advising companies on further development of entrepreneurial skills and entering global markets under the EU4Business Business

initiative). Many other individual states, as well as private and political initiatives, are active in Ukraine and support Ukraine's development in various fields.

A more effective solution for the development of a competitive market is to fix not the final amount of interest rate, but the amount of compensation received by the borrower. It should be noted that according to the NBU, as of December 1, 2020, the total portfolio of loans issued by banks amounted to UAH 964,993 million. The structure of the gross loan portfolio is dominated by loans to the non-financial corporate sector – 77.6%, the share of loans to the consumer sector (individuals) is 21.1%, loans to other sectors – just over 1%. At the same time, the dynamics of the loan portfolio has been almost neutral over the past five years, with a tendency to reduce the share of corporate loans and increase the share of loans to ordinary Ukrainians.

At the same time, the rate of new loans, particularly in the corporate and agricultural sectors, increased significantly by the beginning of 2020 (according to the National Bank of Ukraine), and even taking into account the “quarantine” failure in April-June this year the same period in 2018. This will allow banks to compete with each other on interest rates and will encourage them to find ways to reduce them. In addition, the Affordable Loans 5-7-9% program is very complex in its structure and conditions, which has a negative impact on banks' operating costs associated with administering loans under this initiative.

It is also possible to improve the credit market through mortgage loans. The NBU notes that banks in the fourth quarter of 2021 confirmed the positive sentiment of previous surveys on the dynamics of lending: respondents noted a long increase in demand for loans from households, record growth – from business, and maintained expectations of further demand for hryvnia loans, loans to small and medium-sized businesses and mortgages.

Demand for business loans grew at a record high, with short-term, hryvnia and small and medium-sized loans growing the most.

The determining factors were the need of enterprises mostly in working capital and to some extent in capital investment. Low rates remained a positive factor in increasing demand for farms. Mortgage lending was fueled by lower interest rates. Retail lending standards have been eased for five consecutive quarters. The debt burden of households remains below average.

In 2021, the annual growth of net hryvnia loan portfolios in the corporate segment was 40.5% (+ UAH 93.6 billion), the growth rate of consumer loans accelerated to 37% (+53.5 billion UAH) and exceeded the pre-crisis level. Mortgage loans at the end of November 2021 increased by 60% year on year (+5 billion UAH). There are almost no mortgage loans in the Ukrainian market by the standards of the developed world, but they have great potential. The problem with mortgage financing is exacerbated by the political sensitivity of these products, which could lead to government intervention in the coming crisis. And this, for the most part, is detrimental to banks. To help revive the mortgage market, it is important for the central bank to provide low-cost, long-term financing to small and medium-sized businesses on regulated terms.

In this case, mortgage loan portfolios can serve as collateral. This will make it possible to reconcile the interests of commercial banks and the government in the long run.

Starting in 2018, lending to individuals for the purchase, construction and reconstruction of real estate, including agricultural real estate, is gradually intensifying. In the first quarter of this year, mortgage lending activity continued to grow. In March 2021, banks issued 750 mortgage loans totaling UAH 577.4 million. Loans disbursed increased by 26% compared to February 2021 and 2.4 times compared to March last year.

As of April 1, 2021, Privatbank is the leader in terms of the volume of the mortgage loan portfolio of individuals in the national currency – its loan portfolio forms 20.7% of the total mortgage portfolio of the banking system.

In second place – “Kredobank” (18.3% of the total mortgage portfolio), in third place – “Oschadbank” (15.8%).

Also in the top ten in terms of mortgage loan portfolio are: Ukrgasbank, Ukrsibbank, Globus Bank, Alfa-Bank, Pravex-Bank, Raiffeisen Bank Aval and OTP BANK.

According to the NBU, the ratio of mortgage loans to GDP in 2020 in Ukraine was only 0.7%, which is also much lower than in other countries.

In developed countries, this figure exceeds 25%, and in some countries (France, Sweden, Denmark) reaches more than 50%.

That is, there is room for growth in agricultural construction and mortgage lending. Given the need for a significant part of the population

to improve housing conditions, the mortgage program, which offers affordable loans, with significant public funding has significant prospects for development.

“Great construction” is taking place in Ukraine. Of all the facilities, the program plans to renovate and build thousands of kilometers of roads this year. About UAH 150 billion was planned for this in the budget at the beginning of this year.

In May, Ukravtodor received another UAH 10 billion in state guarantees from the government to attract funding, as the issue of road transport also concerns the agricultural sector in the first place.

Ukreximbank decided to help Ukravtodor in this matter. The bank’s team opened this new financial opportunity for the agency and became the lead manager for a promising deal. The consortium credit mechanism has become the “new – forgotten old” that has already happened in the history of Ukrainian financing.

The loan, which is reportedly referred to as “the first consortium loan in Ukraine”, is not really the first, as is the “first” Ukrainian IPO. Consortium lending has positioned itself in zero years.

In May, Ukravtodor received another UAH 10 billion in state guarantees from the government to attract funding, as the issue of road transport also concerns the agricultural sector in the first place.

Ukreximbank decided to help Ukravtodor in this matter. The bank’s team opened this new financial opportunity for the agency and became the lead manager for a promising deal. The consortium credit mechanism has become the “new – forgotten old” that has already happened in the history of Ukrainian financing.

The loan, which is reportedly referred to as “the first consortium loan in Ukraine”, is not really the first, as is the “first” Ukrainian IPO. Consortium lending has positioned itself in zero years.

At that time, Ukrainian banks were actively borrowing from consortia of international financial institutions and banks. In addition, Ukrainian banks were sometimes not even recipients of such loans, but also provided them.

Such a lending tool has never been widely popular among Ukrainian banks. Such loans have never been widespread. Back then, it was mostly a merger of two banks. There have been examples, but, again, it has never been a popular tool in Ukraine.

In the context of the economic crisis, interest in such lending has taken a secondary position.

It is worth noting that the consortium or, as they are called, syndicated credit in general has a number of advantages as a tool for attracting. It allows a group of banks to invest in large projects that are unaffordable for individual participants. Also, such a loan reduces the risks that would be assumed by one investor, distributing them among the members of the consortium. Such a loan is traditionally considered a more flexible instrument of attraction, compared with bonds. Its organization is fast and cheaper.

This loan creates a positive image for both the borrower and the lenders. According to the consolidated information of the National Bank of Ukraine, “Ukreximbank” as usual for the banks-coordinators of consortium loans, financed the largest share of the loan – 165 million dollars or about 45%. The state-owned “Oschadbank” and “Ukrgasbank” took over about \$ 150 million and \$ 50 million, respectively. That is, the “state” share of this loan totals up to 97%. Private banks provided “symbolic” amounts, compared to the state: “Taskombank” – about 14 million, “Bank Credit Dnipro” – 13 million, and FUIB – 10 million dollars. This is not more than 3% of the total.

In our opinion, for such large amounts, consortium loans in the future will be issued only on the condition of government guarantees or guarantees from local authorities. But now the number of receiving such state guarantees, as well as, for example, portfolio guarantees, is growing. Therefore, this tool will be in demand both in the development of Ukraine’s economy and in the development of new forms of economic entities in the agricultural sector.

The authorities also need to reduce the pressure on banks’ capital, which is growing due to the growth of reserves for loans. This is possible through a revision of the approach to calculating the borrower’s financial class. Also among the important and essential:

- tax liberalization;
- absence of obstacles to out-of-court settlement of debts, to solve problems of enforcement;
- harmonization of legal norms on cancellation of registration actions, consumer lending and financial leasing;

- minimization of risks of loss of security by the mortgagee;
- development of the primary real estate market (programs and guarantees);
- expanding banks' access to state registers.

In addition, temporary mitigation of credit risk assessment requirements will actually help banks.

This would allow lending to expand more rapidly as quarantine is phased out and business activity resumes. And of course, as has been repeatedly emphasized, the creation of sources of “long” resources is crucial for the development of the long-term credit market. An example is the introduction of the second level of pension provision. Banks, in turn, should reconsider their business strategies to reformat potential investments, as well as conduct educational work with potential borrowers.

5. Conclusions

The study provides a theoretical generalization and proposes a new approach to the development of agribusiness in Ukraine, in particular farms. According to the results of the study, a number of conclusions of theoretical and practical nature were formulated.

It is determined that agrarian business as an independent and effective element of a market economy significantly affects the restructuring of Ukraine's economy, contributes to increasing total production, retail trade, creates a favorable environment for competition and eliminates monopoly in business, ie solves many economic, social and other problems.

It is proved that the experience of bank lending to agricultural enterprises is still quite complicated, and also requires a large number of necessary documents from enterprises and their lengthy consideration. The study of financial security – credit support of agricultural formations, namely farms due to the diversification of credit instruments, identified problems with their functioning and justified directions of their development in the context of globalization.

The scientific novelty of the study are proposals to intensify and improve the development of small, medium, farms in Ukraine, based on a number of problems identified during the study. The activities of the represented business entities are complicated by the problems inherent in this type of business entities: the lack of economies of scale, the difficulty of attracting

factors of production; limited production capacity, etc. That is why the success of small and medium business development largely depends on government support and loyal approaches to lending by commercial banks and the implementation of government programs.

As for the prospects of further exploration, in modern conditions it is important to further study the methods, tools and financial levers of influence as components of the financial support of agricultural enterprises.

An important component of achieving the financial goals of an agricultural enterprise is its investment policy. In view of this, the long-term plan of economic development of the entity may include an analysis of the needs of resource provision of production activities, the feasibility of investing and the choice of assets for investment.

References:

1. Abramovich I. A. (2017). Innovative marketing tools of agro-industrial enterprises. *Scientific bulletin of Kherson State University. Series: economic sciences*, vol. 27(1), pp. 107–110.
2. Agrarian export of Ukraine – 2018–2020: raw materials, food products, grain, crop production, dairy, livestock. Available at: <https://agropolit.com/spetsproekty/843-agrarniy-eksport-ukrayini--2015-2020-roki-sirovina-harchova-produktsiya-zerno-roslinnitstvo-molochka-tvarinnitstvo>
3. Artemyeva O. O. (2018). Bank lending to agro-industrial complex: current state and prospects of development. *Scientific bulletin of Uzhgorod National University. Series: International Economic Relations and World Economy*, vol. 21(1), pp. 13–18.
4. Ambrosov V. Ya. (2013). Market and development strategy of agricultural enterprises. *Economy of APK*, vol. 10, pp. 72–79.
5. Aleynikova O. V. (2011). Foreign experience of state regulation of agro-industrial complex development. *Investments: practice and experience*, vol. 6, pp. 131–136.
6. Vazhynskiy F. European experience in reforming the agricultural sector of the economy: opportunities for Ukraine: analytical note. Available at: <http://ird.gov.ua/irdp/e20160202.pdf>
7. Media S. M. (2020). Current state and prospects of development of agro-industrial complex of Ukraine. *Ukrainian Journal of Applied Economics*, vol. 5, no. 2, pp. 402–409.
8. Ivanyuta V. F. (2008). Development of agrarian production of the region: methodological support, state and prospects: monograph. Poltava, 432 p.
9. Official website of the State Statistics Committee of Ukraine. Available at: <http://www.ukrstat.gov.ua> (accessed 02 November 2020).
10. Official. Available at: <http://www.ukrstat.gov.ua> (accessed 02 November 2020).

11. Official website EU4 Busins. Available at: <http://www.EU4Business>
12. Oliinyk O. V., Makogon V. V., Brik S. V. (2019). Problems of optimization of credit support of operating costs of agricultural enterprises. *Economy of APK*, vol. 8, p. 50.
13. Kaletnik G. M. (2020). Differentiation of development of processing industries of agricultural sector of Vinnytsia region. *Economics, Finance, Management*, issue 3, pp. 7–23.
14. Kaletnik G. M. (2020). State regulation of socio-economic development of rural areas in Ukraine. *Economics, Finance, Management*, issue 2, pp. 7–22.
15. Credit program AgroCube. Available at: <https://kub.pb.ua/get-credit>
16. Malinoshevska K. I. (2020). Strategy of development of agro-industrial complex in conditions of regionalization. *Business navigator*, vol. 4(60), pp. 111–115.
17. Mann R. V., Plygach K. D. (2018). Peculiarities of resource and reserve support of economic potential of agricultural sector of Cherkasy region. *Collection of scientific works of CSTU. Series: Economic Sciences*, vol. 50, pp. 23–32.
18. Matrosova L. M. (2020). Problems of development of agro-industrial complex of Ukraine as direction of increasing competitiveness of economy. *Market infrastructure*, vol. 42, pp. 83–90.
19. Matviychuk O. E., Varchenko O. M. (2015). Description of economic conditions of development of agricultural enterprises production activity. *Economics and management of agro-industrial complex*, no. 1. Available at: <http://econommeneg.btsau.edu.ua/sites/default/files/visnyky/economika/matviychuk.pdf>
20. Loan reduction program. Available at: <https://privatbank.ua/business/zdeshevleniya-kredytiv-dlya-fermer>
21. Silicheva N. E. (2019). Small business in Ukraine: state and prospects of development. *Economic innovation*, issue 59, pp. 303–309.
22. Agriculture. Official website of the State Statistics Service of Ukraine. Available at: <http://www.ukrstat.gov.ua>
23. Rulykivskiy V. (2009). The system of indicators of the assessment of the impact of the agro-industrial complex on the efficiency of ensuring the food security of the state. *Bulletin of the National Academy of Public Administration under the President of Ukraine*, no. 1, pp. 114–121.
24. Latifundist. Available at: <https://latifundist.com/dosye/vysotskij-taras>

AGRICULTURAL SECTOR IN THE CONTEXT OF GREEN MODERNIZATION OF ECONOMY

Svitlana Kovalchuk¹

DOI: <https://doi.org/10.30525/978-9934-26-193-0-5>

Abstract. Integration processes that cover the agricultural sector determine the vectors of agricultural production, the state of ecosystems, climate change and environmental degradation, exacerbated by their uneven distribution and increasing pollution, imbalance of development, overcoming which exceeds the capabilities of individual states and need to respond to through broad international cooperation. The study identified the need for a green course, characterized by complex environmental, economic and social interrelationships; the experience of the European Union countries in the direction of green restructuring is analyzed; the importance of the impact of climate change on the development of agricultural production is outlined; key EU documents on the path of green modernization are described; the necessity of resource-saving development is substantiated. Emphasis was placed on the need to intensify efforts to introduce a circular economy to counter the negative effects of climate change and crises.

Based on the situation when key indicators of green growth are included in the most important documents of the country's development, but they are not calculated due to lack of appropriate standards of statistics and accounting, which increases the inability to conduct comparative analysis against regional and global results. This makes it difficult to use them in decision-making on green modernization at all levels and to inform the public. It is substantiated that the strategic directions of the transition to a circular model of agricultural production development, the Ukrainian government together with business and civil society, it is advisable to develop separate roadmaps or action plans with clear directions of expected results. In the presence of clear European guidelines for modernization, it is necessary to use financial support instruments as much as possible. The implementation of closed-loop models in practice will stimulate increased

¹ Candidate of Economic Sciences, Associate Professor,
Vinnytsia National Agrarian University, Ukraine

environmental responsibility and economic efficiency of agricultural production, will improve the overall environmental situation and will be key steps in environmentally oriented development of the agricultural sector.

The aim of the article is to analyze the transformation processes in the agricultural sector, which are caused by climate change, depletion of natural assets and justification of the importance of green modernization of the economy of agricultural production. Realization of the purpose has led to the decision of research tasks: to substantiate necessity of formation of change of a paradigm of development of agrarian sector, to analyze tendencies of introduction of green modernization in the EU countries, to prove expediency of necessity of transition to model of green economy. Domestic agricultural sector, and to ensure the economic and environmental security of the country, because only a circular, resource-saving economy is able to ensure sustainable economic development without harming the environment.

Methodology: the research methodology is based on the dialectical method, which involves the connection of theory and practice, the principles of knowledge of the real world, the determinism of phenomena and processes of interaction between external and internal. The following research methods were used: system-structural; abstract-logical; comparative. Results: According to the results of the study, the degree of modernization of the country's agricultural sector to the EU requirements for a green economy, the European dimension of "green" growth in agriculture, substantiated the feasibility and need for resource-saving agricultural development.

1. Introduction

Modernization of the world economy, the need for balanced development of the world economy, slowing the growth of world trade, all these factors necessitate a fundamentally new approach to economic activity in the agricultural sector of the economy. The urgent problem today is the development of models of "green" growth, along with the need to build the country's potential for greening the agricultural sector; development of systemic long-term measures, which is updated in connection with the aggravation of environmental problems; expanding access to "green" technologies and investments and transferring practical management experience to interested countries and organizations. As a result, the

assessment of the state of implementation of the “green” direction of development of the agricultural sector of the economy in the context of resource-saving development and the circular model needs to be addressed.

Deepened integration into the EU, the main vector of which is the green economy and green growth, the implementation of the Millennium Development Goals, directs all sectors of the economy to seek new forms of use of natural capital. In addition, to ensure the sustainable development of the world economy, it is necessary to introduce ways to counter the slowdown in global economic growth. It is worth noting that modernization models are based on resource-saving, balanced development, rather than increasing production, with significant social protection.

Significant attention is paid to the problems of green economy development by scientific schools of the Institute of Regional Studies of the National Academy of Sciences of Ukraine, the Institute of Market and Ecological and Economic Studies of the National Academy of Sciences of Ukraine, the Institute of Agrarian Economics of the National Academy of Sciences of Ukraine, the Institute of Agroecology University, National University of Food Technology, Odessa State Ecological University, Sumy State University and Sumy National Agrarian University, this is confirmed by a significant number of studies. It should be noted that the scientific reports and reports of the European Commission, the Organization for Economic Co-operation and Development (OECD), the United Nations Environment Program (UNEP).

The aim of the article is to analyze the transformation processes in the agricultural sector, which are caused by climate change, depletion of natural assets and justification of the importance of green modernization of the economy of agricultural production. Realization of the purpose has led to the decision of research tasks: to substantiate necessity of formation of change of a paradigm of development of agrarian sector, to analyze tendencies of introduction of green modernization in the EU countries, to prove expediency of necessity of transition to model of green economy. Domestic agricultural sector, and to ensure the economic and environmental security of the country, because only a circular, resource-saving economy is able to ensure sustainable economic development without harming the environment.

Methodology: the research methodology is based on the dialectical method, which involves the connection of theory and practice, the principles

of knowledge of the real world, the determinism of phenomena and processes of interaction between external and internal. The following research methods were used: system-structural; abstract-logical; comparative. Results: According to the results of the study, the degree of modernization of the country's agricultural sector to the EU requirements for a green economy, the European dimension of "green" growth in agriculture, substantiated the feasibility and need for resource-saving agricultural development.

2. Theoretical foundations of green modernization

Over the last hundred years, many concepts of economic growth have been developed. The main emphasis is on identifying certain aspects of the mechanism of economic growth, its individual factors. This is necessary, especially to develop measures to accelerate economic growth and development. But no less important is a clear definition of their nature. Without this, it is difficult to outline the directions and means of progressive transformation, and to identify ways of further transformation.

Scholars identify several economic processes, such as economic growth, modernization, economic development and social development. Economic growth is a quantitative change in the production system of the country (industry, enterprise), which is expressed in an increase in GDP (GNP) or net product (gross income). Economic growth can occur in some cases without a qualitative change in production systems, which has traditionally been defined as extensive economic growth, in others – accompanied by qualitative improvements in the structure and functions of the production system at one level or another. According to existing terminology, this is intensive economic growth.

Under economic development, understand the purposeful, progressive change of composition, location and interaction of elements, levels and quality of functioning of the production system, increasing its efficiency. Close to the concept of economic development is the modernization of production, which consists in updating the structure and functions of the production system. If these are progressive changes that increase the efficiency of the production system, then such modernization is an integral part of economic development.

There is a complex dialectical connection between economic growth and economic development as quantitative and qualitative changes in

the economy. Economic growth is presented in three variants: positive – with an increase in production; neutral – without changing the volume of production; negative – with a decrease in production. The most common are growth options: based on or in combination with development; without development; with regressive development.

Development as a qualitative improvement of production is more common: in combination with economic growth – with growing demand; with a decrease in production – with a decrease in demand; without economic growth – with stable demand. However, any other option is possible, including the most unfavorable: reducing production with regressive processes at the level of development of the production system.

Thus, summarizing the above, and based on classical economic theory, we note that current models of management expose society to a significant risk of inhibiting growth. Most often, this risk arises from wasteful use of natural capital and neglect of balance in agro-ecosystems. Limited or apathetic implementation of measures aimed at preserving natural capital will inevitably lead to increased costs for its replacement. It is also important that changes in agro-ecosystems and their ability to sustain growth are not necessarily directed in a direct and predictable way. Therefore, in order to avoid the decline of the current level of welfare of the population, new models of production and consumption are needed, as well as fundamentally different approaches to defining the concept of “growth” and measuring its results [11; 31, p. 35–38].

The course of “green” growth has the potential to support economic and social development and is able to provide conditions under which natural assets can continue to provide material goods and services, on which the economy and human well-being depend to a large extent.

At the same time, it should be emphasized that the green transformation of the economy can bring many positive results, such as increased productivity and innovation, the creation of new jobs and markets, as well as new budget revenues. Moreover, ensuring greater resilience to climate change, security of water and energy resources, and the proper functioning of agroecosystems, ie achieving green ecological growth goals, reduces the likelihood of drastic environmental changes that can cause economic and social shocks.

It should be emphasized that to ensure the effectiveness of the green course, national economic policy should stimulate innovation, investment

in sustainable management of natural capital and the withdrawal of higher and long-term profits and benefits from its use [2].

During the transformation processes in Ukraine, it was not possible to increase the economic potential. Some recovery in economic activity in 2016 is insignificant. Instead, resources, capital and time were lost during the structural, energy crisis and pandemic that led to the unsustainable development of the national economy. In turn, the geopolitical conflict, which has lasted for more than eight years, narrows the opportunities for effective development. Ukraine still needs systemic institutional and deep structural reforms, launch of large-scale eco-innovation and technological transformations [14].

As you know, economic growth is understood as changes in the real volume of national production based on the positive dynamics of gross national product.

However, the increase in production is always combined with the depletion of natural resources and environmental pollution, as a result of which the world economy of the XXI century is affected by global environmental problems.

Economic growth is closely linked to the problem of economic development. Economic development can be defined as the transition from one state of the economy to another – qualitatively new, more advanced, based on innovation, structural and institutional changes. Economic growth can occur in the absence of economic development, while economic development is impossible without economic growth. This means that “economic development” is a broader concept than “economic growth” and includes it as the most important condition. Therefore, economic development is determined by traditional factors of economic growth that provide it, ie supply factors, factors of demand and distribution, but it covers a much wider range: the development of science, technology, information services, political and socio-economic factors, and environmental factors, which in the complex are sources of economic development [22].

Today’s environmental and economic problems have become the basis of sustainable development and as a result of the “green” economy. Consideration of the economy as a complex organized and self-reproducing system, where it is necessary to determine the mechanisms of its organization, is being transformed. Note that the modern development of the economy is

characterized by a complex ecological and economic relationship, where the necessary condition is a coordinated interdependence of economic and environmental interests to address ways to adapt to new economic conditions. Scientists have drawn attention to the fact that free or minimal evaluation of a huge number of natural goods and services is the main problem of economic development. When we destroy free nature, it leads to enormous damage. Thus, what has no price or value does not exist for the economy. More than 90% of natural goods and services have no price or valuation, so they do not exist. That is why humanity and all individual countries continue to destroy nature.

However, today the economy of the regions is developing mainly in the direction of self-development, and has a relatively separate reproductive system of management and administration and practically pursues its own export policy. Involving a significant number of countries in the transformation processes of the world economy requires the joint efforts of the governments of these countries and international organizations in order to regulate their development on a global scale [21].

Thus, the transformation processes are manifested in the growing dependence of the economies of the world community, due to the intensive international movement of goods and services, capital flows, rapid and widespread use of new technologies.

3. Experience of EU countries on the path of green transformations

It should be emphasized that the EU Strategies and Framework for Research and Technological Development towards Green Modernization have undergone a long evolution of their development. Work is currently under way in Brussels on a new EU strategy – Europe 2030 and the EU's 9th Framework Program for Research and Technological Development.

The success of the new EU program can contribute to the further development of pan-European cooperation in science and innovation and to building relationships with key partners. Overcoming the crisis within the EU can be achieved through the development of European innovation policy, which is formed at several levels. According to preliminary data, the EU in 2030 will be characterized by funding projects with high “social impact” and education”. The EU faces the challenge of transitioning to a low-carbon economy, sustainable production and consumption, the so-called cyclical

economy, which was presented to the European Commission in a 1976 report and actively promoted in 2012 by the McKinsey Agency. With this in mind, in 2015 the European Commission developed an appropriate action plan [6].

Through the transition to a “cyclical economy” and other “transformations”, the EU is operating successfully in global markets, paving the way for sustainable development and digitalisation. At the same time, artificial intelligence technologies play an important role in digitalization. Member States manage to develop a common policy on these technologies, and all projects allow for high social benefits [6; 9].

In addition, the European Commission has adopted a new EU Biodiversity Strategy to 2030 and the related Action Plan – a long-term plan for nature protection and restoration of degraded ecosystems (from 20.05.2020, COM (2020) 380 final).

In the context of the COVID-19 situation, the biodiversity strategy aims to increase society’s resilience to future threats, such as the effects of climate change, forest fires, food security or disease outbreaks.

The Strategy also emphasizes that the COVID-19 pandemic makes the need to protect and restore nature even more urgent. “A pandemic is an awareness of the connection between our own health and the health of ecosystems. The risk of occurrence and spread of infectious diseases increases with the destruction of nature. Protecting and restoring biodiversity and well-functioning ecosystems is a key factor in increasing our resilience and preventing the emergence and spread of future diseases” strategy said. One of the benchmarks for recovery will be The European Green Deal. The strategy contains specific commitments and actions to be implemented in the EU by 2030, including: creating a larger network of protected areas on land and at sea, creating new and expanding existing protected areas; at least 30% of the land and 30% of the sea must have a conservation status; at least one third of protected areas – 10% of land and 10% of marine waters must be under strict protection; special attention should be paid to virgin and ancient forests, peatlands, meadows, wetlands; It is important to create ecological corridors to prevent genetic isolation, ensure species migration and maintain ecosystem health [23].

The EU’s 2030 Biodiversity Strategy emphasizes key commitments to 2030:

1. At least 30% of the land and 30% of the EU’s marine waters are legally protected and connected by ecological corridors as part of the Trans-European Eco-Network.

2. At least one third of the EU's protected areas shall be strictly protected, including all virgin forests remaining in the EU and old-growth forests.

3. Effective management of all protected areas is ensured, clear conservation objectives and measures are defined and proper monitoring is carried out.

Thus, the EU Nature Recovery Plan is a set of specific commitments and actions to restore and sustainably manage degraded ecosystems in the EU by 2030. Reducing pressure on habitats and species, ensuring sustainable use of all ecosystems, restoring nature, limiting soil compaction, overcoming pollution and invasive alien species, the plan will create jobs, align economic activities with nature and help ensure long-term productivity and value of natural capital. The main vectors are as follows:

1. The EU's legally binding targets for nature restoration, to be proposed by 2021, are subject to impact assessment. By 2030, large areas of degraded and carbon-rich ecosystems will be restored; habitats and species show no deterioration in conservation trends and status; and at least 30% achieve favorable conservation status or at least show positive trends.

2. Decrease in the number of pollinators changes to increase.

3. The risk and use of chemical pesticides is reduced by 50%, and the use of more dangerous pesticides – by 50%.

4. At least 10% of agricultural land has a high degree of landscape diversity.

5. At least 25% of agricultural land is managed by organic farming, and the use of agri-environmental methods is significantly increasing.

6. Three billion new trees have been planted in the EU, in full compliance with environmental principles.

7. Significant progress has been made in the remediation of contaminated soil.

8. At least 25,000 km of free-flowing rivers have been restored.

9. The number of Red List species threatened by invasive alien species is reduced by 50%.

10. Loss of nutrients from fertilizers is reduced by 50%, which leads to a reduction in the use of fertilizers by at least 20%.

11. Cities with at least 20,000 inhabitants have an ambitious Urban Greening Plan.

12. No chemical pesticides are used in sensitive areas, such as EU urban green spaces.

13. Negative impacts on sensitive species and habitats, including the seabed through fishing and mining, are significantly reduced to achieve good environmental status.

14. By-catches of all sensitive species shall be eliminated or reduced to a level that allows species to be restored and preserved.

At the same time, it should be emphasized that in order to achieve these goals, the European Commission will create a new European biodiversity governance framework. A new monitoring mechanism will be introduced to assess progress and corrective action. Particular attention will be paid to measures to stimulate and remove barriers to environmental decision-making, as this can lead to significant opportunities for business and employment in various sectors and is a key to innovation for economic or social needs.

Logically, the question arises about combating biodiversity loss, which must be supported by sound science. Investing in research, innovation and knowledge sharing will be key to data collection and the development of the best environmental solutions. The Commission will promote the new Biodiversity Knowledge Center in close cooperation with the European Environment Agency [23].

Significant public and private investment at national and European levels is needed to overcome biodiversity loss and restore ecosystems. This will mean maximizing the use of all relevant EU funding programs and instruments. To meet the needs of this strategy, including investment priorities for Nature 2000 and environmental infrastructure, at least € 20 billion a year must be set aside for nature spending. This will require mobile private and public funding at national and EU level, including through a number of different programs in the next long-term EU budget. As nature restoration will make a major contribution to climate goals, a significant part of the 25% of the EU budget devoted to climate action will be invested in biodiversity and nature-based solutions [14; 23].

Along with the Biodiversity Strategy, the European Union has presented an ambitious strategy to reduce greenhouse gas emissions by at least 55% by 2030 compared to 1990 levels. It will affect all areas of the economy – from home heating to transport.

The European Commission has adopted a package of proposals that should reduce greenhouse gas emissions in the EU by 2030 by at least 55% compared to 1990 levels.

The strategy calls for Europe to become the world's first climate-neutral part of the world by 2050. The EU will transform all areas of its economy. Until now, Europe has focused on reducing emissions in several sectors, and now climate neutrality extends to the entire economy.

The following measures are envisaged for this: It is proposed to accelerate the transition to green energy so that by 2030 40% of energy is produced from renewable sources. To this end, it is proposed to encourage the abandonment of fossil fuels and the transition to green technologies through tax incentives.

It is proposed to set stricter standards for the transport industry for greenhouse gas emissions: new cars should reduce them by 55% from 2030 (compared to this year), and from 2035 all new cars should be zero emissions. To this end, in particular, it is proposed to expand the network of charging stations on EU roads.

It is proposed to tighten the country's energy saving commitments, in particular by requiring the public sector to modernize its premises to reduce energy consumption and costs for taxpayers. It is also proposed to introduce the world's first carbon tax on imports of certain products. This ensures that reducing emissions in Europe will help reduce emissions around the world instead of displacing carbon-intensive production outside Europe.

One of the main vectors is the expansion of the emissions trading system. Producers' payments for environmental pollution have risen to record levels, and there are fears that these costs will be passed on to consumers [2; 3].

Thus, all countries of the world are thinking about how to restructure their economy so that it is social and inclusive, provides growth and is climate-neutral. This is the goal of the European Green Deal, which is currently being implemented by the European Union.

4. Green modernization is the basis of sustainable development

The economic growth of the world economy in the last decade has posed the problem of a sharp increase in the consumption of natural resources. However, as the economy grows, so does the burden on the environment. Combining economic growth and environmental security is impossible without

modernizing the economy. In addition, when considering the possibility of implementing the standards and practices of the world community, it is necessary to take into account the fact that our country has the richest natural resources and is one of the largest exporters of agricultural products. For this reason, the problems of depletion of natural assets are not yet clearly manifested, while there is a rapid deterioration of the ecological state [4; 18]. Global climate change poses high environmental risks and threats to humanity. The dynamics of global CO₂ emissions show that the world economy has reached a critical level of carbon saturation. And for the last 11 years (since 2009) the growth of CO₂ emissions in the world in some years has outpaced the growth rate of GDP (primarily due to China, India, Russia, Japan) [28].

This process is becoming more and more widespread every year, creating a threat to socio-economic development for a number of countries. Combating climate change in developed and developing countries has begun to require urgent action to achieve unprecedented economic, social and technological change. The amount of resources attracted by world trade increased from 19 billion tons in 2005 to 25 billion in 2018. The UN estimates that by 2050, 9 billion people will consume about 140 billion tons of depleted resources a year – three times more than now. For the modern economy, 60 billion tons of raw materials (22 kg/person/day) are extracted annually. At the same time, the number of resources in the world reached its limit, and as a consequence of rising prices and increasing volatility in agricultural markets [18].

Scholars argue that the main paradigm for the development of the world economy in the 21st century is sustainable development. The following key documents can be highlighted here: The World Conservation Strategy, Our Common Future, The Agenda for the 21st Century, Towards a Green Economy: Ways to Sustainable Development and Poverty Eradication, and The Global Green New course, “Sustainable Development Agenda 2030”, EU Green Agreement (see Table 1).

Given such positions and the urgency of comprehensive expansion in the Ukrainian agricultural sector, the current trends in achieving sustainable development goals, need to expand the scope of research on the current state of agricultural production. It should be noted that resource-saving transformations based on sustainable green growth, environmental protection and inclusive process, as well as taking into account the specifics of national development, are the most effective in this direction.

Key documents of green modernization of the economy

	The name of the document	Contents of the document
1	UN Stockholm Conference on the Environment (1972) "Environmental Action Plan"	health care and welfare of the population; protection of soils and waters and combating desertification; education, professional training and information support of nature protection; protection of the oceans, protection of vegetation, wildlife and genetic resources, problems of energy resources and energy conservation.
2	"World Conservation Strategy" (1980), presented by the International Union for Conservation of Nature and Natural Resources	The very concept of "sustainable development" first appeared in a report where it was defined as the modification of the biosphere and the use of human, financial, reproducible and non-reproducible natural resources to meet human needs. In order for development to be sustainable, it is necessary to take into account not only economic, but also social, environmental and cultural factors in the long run.
3	"Our Common Future" (1987), prepared by the World Commission on Environment and Development (Brundtland Commission)	The conclusions of this Commission laid the theoretical, methodological and conceptual basis for the decisions taken within Rio 92 on the need for civilization to reach the level of sustainable development. The concept of sustainable development became the theoretical basis for human development for the next two decades.
4	1992 United Nations International Conference on the Environment "Agenda for the XXI Century"	Adoption of the main principle of policy and action of UN member states – "meeting the needs of modern times should not undermine the ability of future generations to meet their own needs."
5	Johannesburg World Summit on Sustainable Development (2002) (South Africa)	The Johannesburg Declaration on Sustainable Development has been adopted
6	United Nations Environment Program (UNEP) Global Green New Report (2009)	The three-general purpose is formulated: comprehensively contribute to the recovery of the world economy, preserving existing jobs and creating new ones, while protecting the interests of the most vulnerable groups; reduce carbon emissions and prevent the destruction of ecosystems by directing the economies of different countries on the path of environmentally friendly and sustainable development; to ensure sustainable and comprehensive economic growth and the achievement of the Millennium Development Goals.

Chapter «Economic sciences»

(End of Table 1)

	The name of the document	Contents of the document
7	UNEP Report “Towards a Green Economy: Ways to Sustainable Development and Poverty Eradication” (2011)	The term “green” economy is formulated. UNEP identifies several priority areas for a green economy: efficient use of natural resources; protection and increase of natural capital; pollution reduction; low carbon emissions; prevention of loss of ecosystem services and biodiversity; income and employment growth
8	United Nations Conference on Sustainable Development Rio de Janeiro (Rio + 20) (2012)	Through the efforts of leading countries, a strategy has been developed to reduce poverty, promote social justice and ensure environmental protection measures [10]..
9	In the framework of the 70th session of the UN General Assembly in New York, the UN Summit on Sustainable Development and the adoption of the Agenda for Development after 2015 (2015)	Approved new guidelines for development “Transformation of our world” Sustainable Development Agenda 2030 “17 Sustainable Development Goals and 169 tasks were approved.
10	European Green Deal December 2019	A significant part of the program is the transformation of agriculture: a strategy for sustainable use of chemicals and reduction of CO2 emissions. A number of transformations are envisaged, in particular for rural areas, modernization and changes in approaches to the work of agricultural enterprises, a package of climate laws, development of bioenergy, renewable energy and eco-products.
11	EU Biodiversity Strategy 2030 and related Action Plan of 20.05.2020, COM (2020) 380 final)	In the context of the COVID-19 situation, the biodiversity strategy aims to increase society’s resilience to future threats, such as the effects of climate change, forest fires, food security or disease outbreaks. The strategy contains specific commitments and actions to be implemented in the EU by 2030, including: the creation of a larger network of protected areas on land and at sea, the creation of new and expansion of existing protected areas. at least 30% of the land and 30% of the sea must have conservation status. It is important to create ecological corridors to prevent genetic isolation, ensure species migration and maintain ecosystem health.
12	Farm to Fork Strategy, May 2020	provides for the transformation of food policy and a significant increase in the share of organic farming

Source: compiled by the author using sources [11; 17; 23]

If we analyze the Green Deal strategy, as well as EU policy documents on the circular economy and agriculture (Farm to Fork), we will see that many elements of these policies are already being implemented in Ukraine [9; 13].

For example, in the field of circular economy, Ukraine is already moving to EU standards and requirements for the disposal of electronic equipment, eco-design and eco-labeling. Relevant EU directives and regulations are part of the so-called “industrial visa ban” – the ACAA agreement. Or remember the new Law on Public Procurement, which came into force on April 19 last year. It opens up opportunities for the development of “green” and “life cycle” procurement. This is the main tool to encourage the production of more climate-friendly products. Expanding access to secondary resources is also important for the circular economy.

5. Resource-saving development of the agar sector

The concept of resource conservation is interpreted in scientific papers as conservation and savings. Resource conservation is an organizational, economic, scientific, technical, practical and informational activity that accompanies all stages of the life cycle of facilities and aims to ensure minimum consumption of matter and energy per unit of final product, given the current level of technology and the least impact on man and natural systems [15, p. 17–22]. The concept of resource conservation is based on the tendency to care for natural resources.

At the same time, there is another approach to the interpretation of resource conservation, which is associated with savings (savings) of different types of resources [20, p. 1–14; 26, p. 8–19].

Summarizing the above, it was stated that the development of a resource-saving economy has become an integral paradigm of almost all developed countries, even with sufficient natural resources.

Resource-saving economy – modernization of existing basic industries, increasing their perception of innovation (using the unrealized opportunities of the third, fourth and fifth technological modes) for basic activities [4]. Climate change and resource-saving economy are determining factors influencing the scale and prospects of eco-innovation as a factor in greening Ukraine’s economy, as well as levers and tools to stimulate eco-innovation policy to reduce the gap with European countries in implementing the economic part of the Association Agreement. Ukraine and the EU.

Based on the analysis of interpretations of leading scientists and practitioners on the development of resource-saving economy Musina L., Kvashi T., Polovnikova S., Taran V. it has been proven that economic growth and resource-saving economy are complementary strategies. The growing popularity of the green economy is associated with numerous crises – especially climate, environmental, financial and economic, which determined the need to find alternative ways of development [12, p. 12–31].

Analysis of the G-20 Resource Efficiency Dialogue, Resource Efficient Europe, Europe 2020 Strategy, Circular Economy Strategy, Horizon 2020 Research and Innovation Framework Program makes it possible to state that the relationship between these policy documents is aimed at transformation. In a resource-saving economy that relies on systemic innovation in response to growing challenges from resource constraints and climate change [7].

Of particular note is the rather new document COP26 Main Climate Summit: (2021) [1], which outlined the most likely threats to the global economy: the effects of climate change, cyber threats and economic instability. Climate risks, sustainable development and new technologies that reduce the burden on the environment are key factors that necessitate the modernization of economic growth. It should also be noted that the pandemic has significantly complicated the implementation of the main goal of the UN – to prevent temperatures from rising by more than 1.5 degrees. The summit announced \$ 4.1 billion in financial assistance to developing countries to develop green economies. At the same time, it is emphasized that a number of countries have committed themselves to achieving climate neutrality by the middle of the millennium, while many countries have given up coal and cities are pursuing carbon neutrality.

The European Green Course continues to be a key vector in shaping and developing the EU's climate and environmental policies. The European Commission has approved the Circular Economy Action Plan, the EU Industrial Strategy. In the field of climate, a draft European climate law was presented, public consultations were launched within the framework of the European Climate Pact and on updating the targets for reducing greenhouse gas emissions for 2030. The EU institutions have also worked on the protection of biodiversity and the renewal of agricultural policy, which are one of the key areas of the course. However, the COVID-19 pandemic has made adjustments in this area – the adoption of planned strategies has been postponed.

At the same time, the European institutions are unanimous about the inevitability of reforms under the European Green Course, despite urgent measures to overcome the coronavirus and economic crises. Actions on specific environmental issues caused by the pandemic are being adjusted, guidelines on waste transportation in the EU and waste management in the context of the coronavirus crisis have been published [1; 9; 13].

In Ukraine, the depletion of natural resources, increasing harmful effects on human health, environmental pollution, negative structural changes in the economy, which increase the share of naturally exploiting and polluting industries, are factors that accelerate transformational changes. These processes are evidenced by the inability of modern models to take into account the effects of complex causal relationships between economic assets and natural capital, the inability to ensure their productive use and reproduction [27, p. 120–127]. The application of measures to combat climate change, the introduction and scientific justification of modernization potential and the promotion of new forms of economic cooperation, focuses the attention of scientists on the transition to a closed-loop economy (circular economy).

Against the background of transformation processes is the formation of a new economic model of circular (circular) economy as a type of management aimed at resource and energy conservation, regenerative clean production, circulation and consumption, reuse of raw materials, resources and waste, which are considered resources for the next production cycle.

The Ellen MacArthur Foundation's Towards a Circular Economy-I report (promoting the principles and ideas of the circular economy around the world) highlights the important benefits of the circular economy and sets out the following objectives: and design. In a circular economy, products are designed to be easily reused, disassembled, and fully recovered – or recycled – with the understanding that it is the reuse of vast amounts of material recovered from products that have reached the end of their life cycle. At the same time, there is no extraction of new resources, is, thus laying the foundations for economic growth.

In addition, the circular economy emphasizes the use of renewable energy and the elimination of toxic chemicals that can harm reuse, and aims to eliminate waste through advanced and innovative design of materials, products, systems and, therefore, business models [29, p. 19; 30].

According to the Ellen McArthur Foundation (the initiator of this model), the transition to a “circular” model of consumption will save \$ 700 billion a year in the consumer goods sector in European countries; by 2025, increasing the level of recycling and reuse of waste could create an additional \$ 1 trillion for the global economy. Most EU countries (Denmark, Sweden, the Netherlands) have national strategies for the development of the circular economy and have already experienced significant benefits from its implementation [25].

In turn, the practice of unbalanced agriculture is unfavorable for the environment. Generalization of research on the use of waste in agriculture, taking into account the recommendations of the Framework Draft Law on Waste Management and proposals on compliance with EU waste law (see Table 2), is now fully focused on the circular economy, where the key principle is to avoid waste and maximum increase in the possibility of their reuse [8; 19].

Agricultural waste management must comply with the principles of the five-step hierarchy of waste, the polluter pays principle – the producer of agricultural waste is responsible for waste management costs, and the principle of self-sufficiency and proximity, ie creating a comprehensive network of waste disposal facilities based on best available technologies [8; 16].

This can also be reproduced by the “pyramid” (Figure 1): according to the waste hierarchy, the highest priority is to prevent waste generation (the main part), followed by the optimal use of waste as a resource. Next in the hierarchy – the restoration of nutrients (nutrients) and their use to restore soil fertility. Less important is the use of biomass for energy. The least desirable option is burial (top).

Preference will be given to ways in which simultaneous recovery of nutrients and energy recovery are cost-effective.

The agro-industrial complex can operate without waste at all, as the latter can be converted into feed, compost, fuel or raw materials for the chemical industry. Advantages of avoiding the formation of waste on the farm: reducing the amount of raw materials to be purchased, saving time and money on waste management, reducing environmental damage, compliance of the farm with the requirements of environmental legislation [16].

Use of waste in agriculture*

Wastes of plant origin	
Waste into energy	Stimulating the use of agricultural waste biomass for energy production (introduction of economic instruments); Support for energy production by anaerobic decomposition plants (option – “green tariff”);
general requirements	New requirements for storage, transportation and treatment of agricultural waste, including vegetable origin;
Composting	Introduction of incentives for composting of agricultural waste; Establishing requirements for the quality of compost and raw materials for compost; Establishing requirements for the introduction of compost into the soil;
Incineration	New requirements for vegetable waste incineration;
Waste in the feed	Introduction of mechanisms for providing subsidies for the collection and transportation of plant waste suitable for the production of feed for animal fattening;
Animal waste	
general requirements	Establishing requirements for treatment, recycling, recovery and disposal of animal by-products;
Composting	Stimulating the introduction of composting of agricultural waste; Establishing requirements for the quality of compost and raw materials for compost; Establishing requirements for the introduction of compost into the soil; Establishing requirements for the introduction of animal excrement into the soil; Establishment of veterinary and sanitary requirements for the use of animal by-products; Creation of a network of regional facilities for environmentally friendly processing of animal waste; Establishing requirements for the development of animal excrement management plans for farms with breeding facilities: poultry (40 thousand places and more); pigs (1 thousand seats and more, for sows – 500 seats and more); cattle and small cattle (1 thousand places and more); rabbits and other fur animals (2,000 or more).
Fertilizers means to improve yields, agrochemistry	
	Establishing requirements for the composition and quality of organic fertilizers; Establishing requirements for the use and storage of agrochemicals that meet EU requirements

Source: [4; 19]

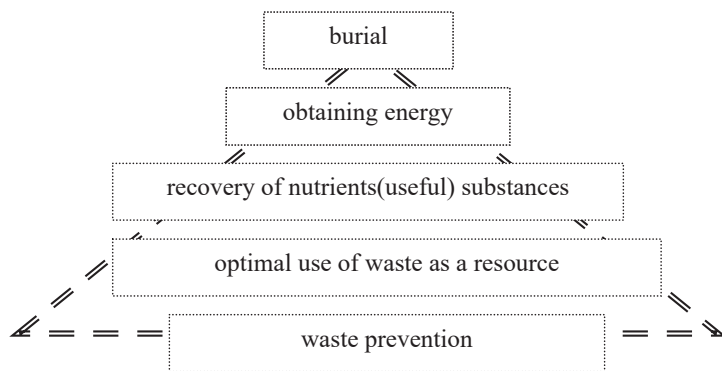

Figure 1. Pyramid of agricultural waste management

The European Union has ambitious plans to develop organic agricultural production and reduce the use of pesticides and fertilizers. This is a great advantage for Ukraine, as 468 thousand hectares of land have organic status. The EU aims for the status of organic land to be 25%, currently in the country about 1%. But at the same time in absolute numbers – this is the tenth place among European countries. The development of organic agriculture depends entirely on our trade with the EU, 70% of exports of organic products are EU countries.

In 2022, it is planned to complete the implementation of our system of control over organic production and ensure its recognition in the EU. This will greatly simplify trade and strengthen confidence in Ukrainian products. However, in Ukraine pesticides are used 1.35 kg per hectare with EU targets of 1.55 kg.

Therefore, the integration of agriculture between Ukraine and the EU aims to ensure better quality of agricultural products and efficiency of agricultural production, rather than reducing the use of chemicals. Farmers are fully prepared to implement the goals of the Farm to Fork policy in order to achieve these goals in the most effective way [9; 13].

Given that the closed-loop economy is a fundamentally new model that will have economic, environmental and social effects for both domestic enterprises and to ensure economic and environmental security of the country, because the circular economy is able to ensure sustainable economic

development without harming the environment. environment [10, p. 41–57]. The national waste management strategy is not a way of restructuring the Ukrainian economy from a straightforward to a closed one, but only its initial stage. With the transition to a closed-loop economy, there is a need to introduce new, resource-saving and environmentally friendly business models.

To date, scientists emphasize the classification of models of management in a circular economy, which provide a cycle of resources. This classification was developed by the international consulting agency Accenture as one of the results of the study “Circular Advantage: Innovative Business Models and Technologies to Create Value in a World without Limits to Growth” [29].

Thus, the essence of the circular economy is as follows, its desire to repeat the natural system, where everything that is produced or used is completely processed in the middle of the system so that there are no environmental problems.

Green modernization, a planned transition to closed-loop models in the agricultural sector, will not only make a profit for farmers, but also prevent pollution of air, water and land resources with harmful substances, while providing favorable conditions for human life. With the strategic directions of transition to a circular model of agricultural production development, the Ukrainian government together with business and civil society should develop separate roadmaps or action plans with clear directions of expected results. In the presence of clear European guidelines for modernization, it is necessary to use financial support instruments as much as possible. The implementation of closed-loop models in practice will stimulate increased environmental responsibility and economic efficiency of agricultural production, will improve the overall environmental situation and will be key steps in environmentally oriented development of the agricultural sector.

6. Conclusions and prospects for further research

1. The processes of modernization of the economy of agricultural production are characterized by increasing requirements for environmental protection, which is a necessary requirement for green growth. Thus, the environmental factor has become an integral part of economic growth, but not the source of growth. Green growth is an integral condition for the sectoral greening of agricultural production, ie it is a powerful factor in restructuring the economy on the path of green modernization.

2. Strengthening the requirements for control over the state of the environment and the quality of agricultural products encourages agricultural producers to transition to a closed-cycle economy, a circular economy and the transition to organic production.

3. The priority for the country is to meet the requirements of the free trade area with the EU in the field of agricultural production, which can be realized by increasing the export of safe agricultural products. This area of trade relations creates stability and competitiveness in the European market. However, existing progress remains volatile. Given the current realities, the EU cannot effectively influence the introduction of green growth in the country to meet today's challenges, it is the will of the country itself.

4. Long-term prospects for modernization and sustainable development of the country are not able to resolve territorial disputes, which significantly reduces the opportunities and motivation to implement green growth goals.

5. Resource-saving transformations, as an integral part of economic growth, ensure the sustainable development of the agar sector. Current and promising strategic and policy documents do not fully cover current trends in the implementation of greening policies and the transition to a green economy in the industry, including the introduction of resource-saving, energy efficient, safe and environmentally friendly technologies for agricultural production and agriculture. climate change, the contribution of agriculture to greenhouse gas emissions and the implementation of measures to reduce them, etc.

6. The solution to these problems depends on strengthening the requirements for the conservation of resources with the provision of green growth, which effectively meets the needs of society without depletion, degradation and pollution of nature. Thus, with a sound approach, a systematic transition to closed-loop models in the agricultural sector will accelerate integration processes, propose appropriate measures focused on the capabilities of economic entities in the agricultural sector.

7. Based on the situation when key indicators of "green" growth are included in the most important documents of the country's development, but they are not calculated due to lack of appropriate standards of statistics and accounting, which increases the impossibility of comparative analysis against regional and global results. This makes it difficult to use them in decision-making processes at all levels and to inform the public. However,

the use of an expanded system of green growth indicators or a system of key indicators (core/key indicators) will allow strategic planning to assess the processes of economic modernization. The definition of OECD Green Growth Indicators under the EU4Environment (2019) program will allow Ukraine to monitor green growth, which is the subject of further research.

References:

1. Ghlavnyj klymatycheskij sammyt COP26 [COP26 Major Climate Summit]. Retrieved from: <https://www.epravda.com.ua/rus/news/2021/11/2/679296/> (accessed 10 February 2022).
2. «Zelenuj» rost y pryrodookhrannoje upravlenye v stranakh Vostochnoj Evropu, Kavkaza y Central'noj Azyy [Green growth and environmental management in Eastern Europe, the Caucasus and Central Asia]. Retrieved from: <https://www.oecd.org/env/outreach/48876138.pdf> (accessed 10 February 2022).
3. Zelena ughoda Jevropy, abo osnovy Green Deal: shho prynese aghro-sektoru Ukrainy kurs na ekologhichnistj [The Green Agreement of Europe, or the foundations of the Green Deal: that will bring the agricultural sector of Ukraine a course on environmental friendliness]. Retrieved from: <https://agropolit.com/spetsproekty/825-zelena-ugoda-yevropi-abo-osnovi-green-deal-scho-prinese-agro-sektoru-ukrayini-kurs-na-ekologhichnist> (accessed 10 February 2022).
4. «Zeleni» investyciji u stalomu rozvytku: svitovyj dosvid ta ukrajinsjkyj kontekst [«Green» investments in sustainable development: world experience and Ukrainian context]. Retrieved from: www.razumkov.org.ua (accessed 10 February 2022).
5. Danylyshyn B.M., Masljukivsjka O.P. (2008). Rozroblennja nacionaljnykh strategij stalogho rozvytku: korysnyj dosvid dlja Ukrainy [Developing national sustainable development strategies: a useful experience for Ukraine]. *Mekhanizm rehuljuvannja ekonomiky – The mechanism of regulation of the economy*, vol. 3(2), 1, pp. 26–30. (in Ukrainian)
6. Evropa-2030: ramochnaja prohramma Evropejskogho sojuza po yssledovanyjamy tekhnologhycheskomu razvytyju [Europe 2030: the European Union's framework for technological development research]. Retrieved from: https://mgimo.ru/library/publications/evropa_2030_ramochnaya_programma_evropejskogo_soyuza_po_issledovaniyam_i_tekhnologhycheskomu_razvytyju/ (accessed 10 February 2022).
7. Eko-innovaciji v resursoefektyvnyj ekonomici: suchasni koncepciji. Rushiji rozvytku ta bar'jery, rekomendaciji shhodo polityky poshyrennja v Ukraini [Eco-innovations in a resource-efficient economy: current concepts. Development drivers and barriers, recommendations for distribution policy in Ukraine] / uklad.: L. Musina, T. Kvasha. OON z prom. rozvytku, Tsentr resursoefektyv. ta chystoho vyrobnytstva v Ukraini. Kyiv: UkrINTEI, 2017. Retrieved from: http://www.uintai.kiev.ua/images/files/monografii/monografiya_12-2017.pdf (accessed 10 February 2022).

8. Ekologhichni aspekty ghospodarsjkoji dijaljnosti pidprijemstv [Ecological aspects of economic activity of enterprises]. Retrieved from: www.bakertilly.ua (accessed 10 February 2022).

9. Dovkillja i klimat: iformacijno-analitychnyj oghljad ekologhichnoji ta klimatychnoji polityky i prava JeS [Environment and Climate: An Information and Analysis Review of EU Environmental and Climate Policy and Law]. Retrieved from: <https://www.rac.org.ua/uploads/content/569/files/2eumarchapr2020.pdf> (accessed 10 February 2022).

10. Zvarych I. (2017). Cyrkuljarna ekonomika i globalizovane upravlinnja vidkhodamy [Circular economy and global waste management]. *Journal of the European economy*, vol. 16, no. 1(60), pp. 41–57.

11. Kovalchuk S., Kravchuk A. (2019). The impact of global challenges on “green” transformations of the agrarian sector of the eastern partnership countries. *Baltic Journal of Economic Studies*, vol. 5 no. 1, pp. 87–97. DOI: <https://doi.org/10.30525/2256-0742/2019-5-1-87-95>

12. Kvasha T. K., Musina L. A. (2015). Vymirjuvannja zelenogho zrostannja v Ukrajinii: koncepciji, systemy indykatoriv, dosvid formuvannja ta perspektyvy zastosuvannja: monoghrafija [Measuring Green Growth in Ukraine: Concepts, Indicator Systems, Formation Experience and Prospects: monograph]. Kyiv: UkrINTEI. (in Ukrainian)

13. Klymatycheskaja nejtralnostj do 2050 ghoda: plan dejstvyy dlja Ukraynu [Climate neutrality until 2050: an action plan for Ukraine]. Retrieved from: <https://www.eurointegration.com.ua/rus/experts/2021/01/20/7118731/> (accessed 10 February 2022).

14. Ministerstvo ekonomichnogho rozvytku i torghivli Ukrajinny. Nacionaljna dopovidj «Cili Stalogho Rozvytku: Ukrajinny» [Ministry of Economic Development and Trade of Ukraine. National Report “Sustainable Development Goals: Ukraine”]. Retrieved from: <https://menr.gov.ua/files/docs>. (accessed 10 February 2022).

15. Meljnyk L.H. (2010). Ekonomika pryrodnykh resursiv [Economics of natural resources]. Sumy: Universitetskaja kniha. (in Ukrainian)

16. Ministerstvo energhetyky ta zakhystu dovkillja [Ministry of Energy and the Environment]. Retrieved from: <https://menr.gov.ua/news/33413.html> (accessed 10 February 2022).

17. OON Ukrajinna. Cili stalogho rozvytku [UN Ukraine. Sustainable Development Goals]. Retrieved from: <http://www.un.org.ua/ua/tsili-rozvytku-tysiacholittia> (accessed 10 February 2022).

18. Partnerstvo vo imya okuzhayushchey sredey i ekonomicheskogo rosta (2013–2018) [Partnership for the environment and economic growth (2013–2018)]. Retrieved from: www.unido.org/eapgreen (accessed 10 February 2022).

19. Nacyonalnaja strateghyja upravlenyja otkhodamy v Ukrayne [National Waste Management Strategy in Ukraine]. Retrieved from: <https://dlf.ua/ru/zatverdzheno-natsionalnu-strategiyu-upravlinnya-vidhodami-v-ukrayini-do-2030-roku/> (accessed 10 February 2022).

20. Polovnykova S. Ju. (2003). Resursozberezhennja v rozshyrenomu vidtvorenni transformacijnoji ekonomiky [Resource Saving in the Extended

Reproduction of a Transformational Economy]. Extended abstract of candidate's thesis. Dnipropetrovsk. (in Ukrainian)

21. Stalyj rozvytok i zelena ekonomika [Sustainable development and green economy]. Retrieved from: <https://eco-live.com.ua/content/blogs/staliy-rozvitok-i-zelena-ekonomika> (accessed 10 February 2022).

22. Salatjuk N. M. (2019). Aktualjni aspekty perekhodu do modeli stalogho rozvytku v Ukraini [Current aspects of the transition to the model of sustainable development in Ukraine]. Retrieved from: http://www.rusnauka.com/4_SND_2013/Economics/14_126770.doc.htm (accessed 10 February 2022).

23. Strateghiya bioriznomanittja JeS do 2030 roku: Povnennja pryrody u nashe zhyttja [EU Biodiversity Strategy to 2030: Returning nature to our lives]. Retrieved from: <http://www.epl.org.ua/announces/strategiya-bioriznomanittja-yes-do-2030-roku-povnennya-pryrody-u-nashe-zhyttja/> (accessed 10 February 2022).

24. Sotnik I. M. (2006). Resursozberezhennja ta ekonomichnyj rozvytok Ukrainy: formuvannja mekhanizmiv perekhodu sub'ektiv ghospodarjuvannja Ukrainy do ekonomichnogho rozvytku na bazi resursozberighajuchykh tekhnologij: monohrafija [Resource saving and economic development of Ukraine: formation of mechanisms of transition of Ukrainian Business entities to economic development on the basis of resource-conserving technologies: monograph]. Sumy: Universitetskaia kniha. (in Ukrainian)

25. Suprun N. A. (2018). Novi modeli ekonomiky: chy ghotova ekonomichna nauka pryjnjaty vyklyk? [New economic models: is economic science ready to meet the challenge?]. DU «Instytut ekonomiky i prohnozuvannja NAN Ukrainy». Retrieved from: <http://ekmair.ukma.edu.ua/handle/123456789/14560> (accessed 10 February 2022).

26. Taran V. A. (2003). Resursosberezenie – novyy simvol sotsial'no-ekonomicheskogo i nauchno-tehnicheskogo progressa [Resource-saving is a new symbol of socio-economic and scientific-technical progress]. *Mashinostroitel*, vol. 12, pp. 8–19. (in Russian)

27. Tymoshenok I. L., Dronova O. L. (2018). Syrkuljarna ekonomika dlj aumov Ukrainy [Circular economy for the conditions of Ukraine]. *Formuvannia rynkovykh vidnosyn v Ukraini*, vol. 9, pp. 120–127.

28. FAO: jak pokrashhyt zdorovja planety [FAO: how to build a healthy planet]. UN Ukraine. Retrieved from: <http://www.un.org.ua/ua/informatsiyni-tsentr/news/4668-fao-iak-pokrashchyty-zdorovia-planety> (accessed 10 February 2022).

29. Lacy P., Keeble R., McNamara R. (2015). Circular advantage innovative business models and technologies to create value without limits to growth. Accenture. Retrieved from: https://www.accenture.com/t20150523t053139_w_/us-en/_acnmedia/accenture/conversion-assets/dotcom/documents/global/pdf/strategy_6/accenture-circular-advantage-innovative-business-models-technologies-value-growth.pdf (accessed 01 February 2022).

30. SITRA (2017). The most interesting companies in the circular economy in Finland. Retrieved from: <https://www.sitra.fi/en/projects/interesting-companies-circular-economy-finland/> (accessed 10 February 2022).

31. Chetvertakova V., Chetvertakov I. (2008). Ekonomichne zrostantnja i rozvytok [Economic growth and development]. *Economist*, vol. 11, pp. 35–38.

**CURRENT STATE AND DIRECTIONS
OF INTEGRATION OF UKRAINE'S PENSION SYSTEM
INTO THE EUROPEAN AND WORLD PENSION SYSTEM**

Olena Martseniuk¹

DOI: <https://doi.org/10.30525/978-9934-26-193-0-6>

Abstract. In Ukraine, the problem of building an effective system of social protection that can respond quickly to modern economic processes, provide citizens with a decent life, guarantee pensions and other social benefits at the level of market realities and state social standards remains one of the important objectives of public policy. The subject of the study is the pension insurance system in Ukraine, the activities of insurance companies in the pension system.

The aim of the research is to study the theoretical foundations and practical aspects of pension insurance, the functioning of the Pension Fund of Ukraine and private pension funds, the formation and use of their funds and justify possible ways to improve the pension insurance system in Ukraine. to international standards.

In accordance with the set goal, the following tasks were identified: to characterize the theoretical foundations of the functioning and development of pension insurance in Ukraine; to study the experience of reforming the pension systems of foreign countries, to analyze the current state of the pension system in Ukraine; to characterize the problems of development of non-state pension insurance and to develop measures to intensify pension insurance programs taking into account international experience; to determine the directions of integration of the pension system of Ukraine into the European and world pension system.

The scientific novelty of the obtained results lies in the substantiation of theoretical and methodological strategic development of the pension insurance system in Ukraine, which allowed to obtain practical and theoretical results that contain scientific novelty, in particular the prospects

¹ Candidate of Economic Sciences,
Associate Professor of Department of Finance, Banking and Insurance,
Vinnytsia National Agrarian University, Ukraine

of its development in modern conditions. The most significant scientific results of the research, which are marked by novelty, are the following: the main positive properties of the accumulative system of state pension insurance are summarized, namely: the ability to strengthen the motivational factors of the population to participate in pension insurance.

In this system, there is a much closer link between the contributions made and the pension benefits received than in the solidarity pension system, which makes it possible to weaken paternalistic sentiments in society; the structure of such a mechanism of state regulation of financial support of the pension system is generalized, which includes a set of institutional and technological interconnected blocks, created based on the goals and directions of state management of the pension system; It is substantiated that the further development of private pension provision can reduce the burden on the state pension insurance in the future and supplement it with new pension insurance schemes, which are not available to the population in the mandatory state pension insurance. The intensification of the activity of the system of non-state pension funds and the accumulative pension fund will become a significant source of investment resources in the economy of Ukraine and will contribute to ensuring its financial security.

The practical significance of the obtained results is to develop and provide recommendations on the peculiarities of the development of pension insurance and areas of reform.

1. Introduction

In Ukraine, the problem of building an effective system of social protection that can respond quickly to modern economic processes, provide citizens with a decent life, guarantee pensions and other social benefits at the level of market realities and state social standards remains an important component of public policy. Today, a unique situation has arisen, when the need for changes in the pension system is clearly recognized by the state, which is becoming hostage to the socio-demographic and economic situation, and the population of Ukraine, retirees themselves, who cannot satisfy the current level of pensions.

Building a pension system that meets the requirements of a market economy is one of the most important tasks to be solved in the social sphere of the country. The imperfection of Ukraine's pension system is an extremely important issue,

as a proper three-tier pension system has not been established. Demographic projections continue to be disappointing: the number of employees continues to decline, and the number of retirees is increasing every year.

Ukraine has a unified pension system. It is manifested primarily in the fact that the payment of pensions to almost all categories of pensioners is carried out at the expense of the Pension Fund of Ukraine and, in part, subsidies from the State budget, which are allocated for pensions. The unified system provides for centralized legal regulation, which guarantees equal conditions and norms throughout the country, equal opportunities for citizens of Ukraine to exercise one of the most important social rights.

Ukraine has historically developed a one-tier pension scheme based on intergenerational solidarity, which is in some way consistent with the command-and-control system. Under market conditions, it does not provide citizens with adequate pensions to replace their lost earnings due to old age and prevent poverty among the elderly. As a result, both pension payers and the vast majority of retirees are dissatisfied with the current pension system. Procrastination with the elimination of these contradictions can lead to acute and protracted social tensions.

However, Ukraine is forming a classic three-tier pension system. The third level is created in the form of voluntary private support for pension schemes with certain contributions. It is based on private pension funds (NPFs), whose activities in the country cannot yet be called active.

The aim of reforming the pension system is to ensure a decent standard of living for the elderly on the basis of social justice, harmonization of relations between generations and promote economic growth.

Pension reform should be carried out on a systemic basis, tested by the experience of other countries and adapted to Ukrainian conditions, namely:

- social justice, acceptability, understanding and support for reform by the general population;
- freedom of choice, increasing interest and responsibility of citizens for their well-being in old age;
- economic soundness and financial capacity and sustainability of the pension system;
- promoting the growth of national savings and economic development of the country;
- protection from political risks.

Pension systems are improving almost all over the world, especially in countries with highly developed social relations. This is due to trends in population aging. Therefore, in addition to raising the retirement age, other pension systems are being built on fundamentally new principles, which disperse risks and reduce their impact.

To this end, a multilevel pension system is increasingly used in world practice, which has three components – solidarity (first level), mandatory accumulative (second level) and additional or voluntary accumulative (third level). This combination ensures social security and financial stability of the pension system. After all, solidarity and savings systems are subject to various risks: the first is vulnerable to demographic risks and quite resistant to inflation, and the second – vice versa. The reformed solidarity component will take into account the interests of the poor, and the accumulative component will stimulate the pension savings of all citizens, especially those with higher incomes.

A multi-level pension system is the most acceptable for Ukraine. With this in mind, pension reform should be carried out in three areas: reform of the solidarity system, the creation of a mandatory savings system and the development of a voluntary savings system. The solidarity system must prevent poverty among the elderly by redistributing part of the Pension Fund to low-income citizens.

The main purpose of the introduction of the funded pension system is to increase the amount of pensions at the expense of income received from investing part of the pension contributions of citizens. At the same time, pension funds should be accumulated both through mandatory pension insurance and the creation of additional (voluntary) pension savings.

In the initial stages of the reform, the pension provision of persons who will not participate in the mandatory savings system will be provided at the expense of the solidarity system.

The need for additional funds for the fulfillment of double obligations will be maximal in the first stages of the pension system reform and will continue to gradually decrease due to the reduction in the number of persons receiving pensions exclusively from the solidarity system.

An important and necessary condition for the introduction of a multilevel system is the transition to a parity system of pension contributions – equally by employers and employees.

The private pension system plays an important role in providing for the population. It is a safe, and in most cases – a preferential means of ensuring a decent standard of living after working.

Another, no less important function of the private pension system is that it is a source of long-term investment necessary for the economic development of the country. For example, in the United Kingdom, the Netherlands and Switzerland, investment in this system exceeds half of GDP.

As world experience shows, the development of private pensions is an integral part of the country's successful progress in market conditions, because the funds invested in it will not only provide a stable income for retirees in the future, but also work for the national economy and enterprises. Return in the form of investment capital.

During the implementation of the third level of the pension system, Ukraine faced a number of problems, in particular: contradictory issues of state regulation and taxation, insufficient level of development of financial markets. They also include low public awareness of the activities of new institutions in the economy (private pension funds) and, as a result – public distrust in their activities.

The functioning of the pension system is influenced by a number of factors that help shape not only the direction of social policy, but also the economic stability of the country. Today there is a question of improving the current system of social protection and the development not only of compulsory state pension insurance, in order to create a stable financial base for the elderly, but also the formation of a strong pension system as a whole. The development of private pension insurance, which occupies an extremely important place in the system of social protection of the working population, is expedient in this direction. In Ukraine, this area is already actively developing, and the first result is the emergence of private pension funds [3].

Radical reform of the pension system is an urgent task of today's stage of socio-economic transformations in our country and is important for the social security of pensioners and sustainable development of Ukraine. Despite the fact that a number of important changes have been made to date for the further development of the pension system, the pension reform has not yet been completed, as the Pension Fund of Ukraine still cannot do without subsidies from the budget, pensions do not protect against poverty. and income in general, the system remains socially unjust and so on.

Therefore, the study of the peculiarities of the formation and development of pension insurance and, in particular, the functioning of insurance companies and private pension funds of their general condition and problems is currently relevant.

2. Analysis of the current state of pension insurance in Ukraine

Man's productive work, his desire to improve his quality of life, well-being and social status have been and are one of the main factors of social progress. Unfortunately, however, the realities of life are such that, for objective reasons, not everyone is able to realize themselves as an active member of society, and most people who have had this opportunity throughout their lives lose it over time. Therefore, the problem of social security of man in old age, in case of illness and disability is one of the most relevant for every civilized society, which is based on the principles of universal morality and cares for its disabled members.

At different times and in different countries, social security issues were addressed in different ways – their solution through the family support of the disabled, through charity, through the formation of various public and professional associations designed to provide appropriate support. However, these measures were not systemic in nature and consistent, they were rather separate attempts to solve the problem, rather than a comprehensive solution.

In the first year of Ukraine's independence, there were 13.1 million pensioners in the country, and in two years it increased to 14.2 million.

In 1994–2000 there were 14.5 million retirees, in 2001–2004 there were 14.4 million in the country. Over the next few years the number of retirees in Ukraine began to decline: in 2005 – 14.1 million, in 2006 – 14 million, in 2007 – 13.9 million, in 2008 – 13.8 million, in 2009–2011 – 13.7 million [8].

It should be noted that in 2011 Ukraine began to increase the retirement age for women – from 55 to 60 years. At least 15 years of service is required for retirement. The insurance period for men was set at 35 years, for women – 30 years.

In 2012, there were 13.8 million pensioners in Ukraine, in 2013 – 13.6 million, in 2014 – 12.1 million, in 2016 – 12.3 million, in 2017 – 11.9 million, in 2018 – 11.7 million, in 2019 – 10.9 million, in 2020 – 10.8 million [7].

As of October 1, 2021, there are 10.6 million retirees in our country (Figure 1).

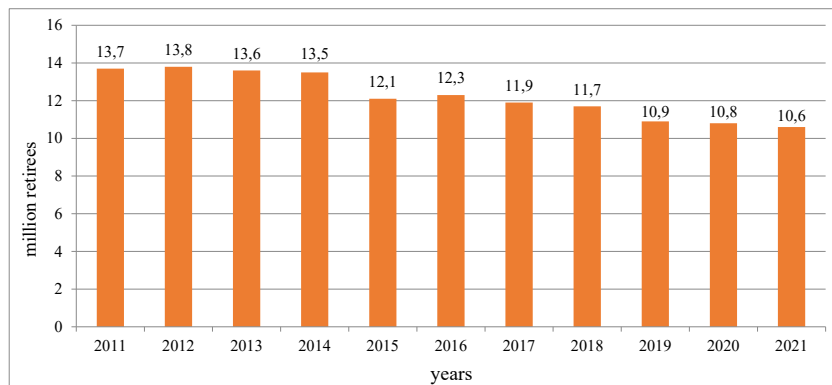

Figure 1. The number of retirees in Ukraine in 2011–2021 [8]

Today in Ukraine, in order to form a reliable pension provision for the population, it is first necessary to transform the state economy on a market basis, as the main mechanisms of economic coordination are the relationship between the market and the state. Since April 2021, the retirement age for men and women has been equated to 60 years. But Ukraine has a system of voluntary pension savings. Today, about 900,000 people have savings in 60 private pension funds.

In 2020, in accordance with the resolution of the Cabinet of Ministers of Ukraine from 01.04.2020 № 251 “Some issues of increasing pension benefits and providing social support to certain categories of the population in 2020” from 01.04.2020 established:

- a monthly compensation payment to persons aged 80 and over in the amount of UAH 500, in which the amount of pension payments, including allowances and increases, does not reach the average salary taken into account for calculating pensions for 2019, and the minimum pension payment at UAH 2,600 to such persons, if they have the relevant insurance experience (20 years – women, 25 years – men);

- one-time cash benefit in the amount of UAH 1,000. certain categories of the population, in particular persons from the number of recipients of

pensions, state social assistance to persons with disabilities from childhood and children with disabilities and state social assistance to persons who are not entitled to a pension, as well as persons with disabilities.

From 01.05.2020:

– pensions were transferred using the coefficient of increase of the average salary (income) in Ukraine, from which insurance premiums were paid, which is taken into account for the calculation of pensions, in the amount of 1.11;

– As of July 1, 2020, the average amount of pension payments increased to UAH 3,394 against UAH 3,006 as of July 1, 2019;

– The number of people receiving less than UAH 2,000 decreased by 60.4%.

At the same time, the Government is concerned about improving Ukraine's pension system. In particular, work is underway on the introduction of a funded pension insurance system and the development of a voluntary non-state pension system.

Today, when our life expectancy is increasing, the birth rate is falling, the number of those entering the labor market is decreasing. 2019 was the worst year for demographics.

The birth rate in Ukraine in 2019 fell to the lowest level in history – 7.4 newborns per 1,000 populations. Today, there are fewer Ukrainian citizens under the age of one in the country than residents of any other age up to and including 72 – this is the first time this has happened. In terms of birth rate, Ukraine is among the five worst indicators in the world. We already have 13 million people who are paid contributions to the Pension Fund of Ukraine, and 11.2 million retirees. And in 30 years due to demographics, this situation will only get worse. Pension expenditures will increase. We need a balance between the two systems – the solidarity system and the accumulative pension insurance system, which eliminates risks. The accumulative system is independent of demographics, but is exposed to financial risks, solidarity – on the contrary [8].

Every year, the ability of the solidarity system to provide a decent pension for citizens is deteriorating. The current pension system in Ukraine is facing important social and financial challenges that need to be addressed urgently, as these challenges will only intensify over time. Despite the rather significant amount of expenditures of the Pension Fund for the payment of

pensions, the average amount of pension payments is UAH 3,507.5 as of January 1, 2021, which is much lower than in other European countries. It should be noted that 57% of pensioners, unfortunately, receive an average pension of about 2,500 UAH.

3. The main trends in the pension provision of citizens

In 2021, there will be changes in the pension provision of citizens, related, in particular, to the conditions for acquiring the right to an old-age pension, terms of pension recalculation, increase of the minimum old-age pension and minimum pension payment, maximum pension, allowances and pension increases in connection with the growth of the subsistence level for disabled citizens, etc.

We describe the main changes:

1. Minimum old-age pension

If you have at least 35 years of insurance experience for men, 30 years for women (for those appointed before 1.10.2011, respectively 25 and 20 years), the minimum pension is set at the subsistence level for persons who have lost their ability to work, defined by law 28 of the Law of Ukraine “On Compulsory State Pension Insurance” of July 9, 2003 № 1058 (hereinafter – the Law № 1058): from January 1 – UAH 1,769.00, from July 1 – UAH 1,854.00, from December 1 – UAH 1,934.00.

For persons who have reached the age of 65, with at least 35 years of insurance experience for men, 30 years for women, the minimum old-age pension is set at 40% of the minimum wage set by the law on the State Budget of Ukraine for the year, but not less than the subsistence level for persons who have lost their ability to work, as defined by law. Since the minimum wage in 2021 will be: from January 1 – UAH 6,000, from December 1 – UAH 6,500, respectively, the minimum pension for this category of retirees in this year will be: from January 1 – UAH 2,400, from December 1 – UAH 2,600 (part two of Article 28 of the Law № 1058).

Persons covered by the Law of Ukraine “On Increasing the Prestige of Mining” and employees working full time underground to serve these persons who have worked in underground work for at least 15 years men and 7.5 years women on the list № 1 production, jobs, professions, positions and indicators approved by the Cabinet of Ministers of Ukraine, the minimum old-age pension is set regardless of the place of last work in the

amount of 80 percent of salary (income) of the insured person determined in accordance with Article 40 of Law №1058, from which the pension is calculated, but not less than three subsistence minimums established for persons who have lost their ability to work: from January 1 – UAH 5,307.00, from July 1 – UAH 5,562.00, from December 1 – UAH 5,802.00 (part one of the article 28 of the Law № 1058).

2. Minimum pension payment

If the amount of the pension granted in accordance with the Law №1058, taking into account statutory allowances, increases, supplementary pensions, targeted cash benefits, indexation amounts and other pension supplements (except pensions for special services to Ukraine) for persons with insurance experience of 35 years – for men, 30 years – for women, does not reach 2,100 UAH, such persons at the expense of the State budget is paid a supplement to the pension in the amount not enough to the specified amount (Resolution of the Cabinet of Ministers of Ukraine from 01.04.2020 № 251).

For persons who have reached 80 years of age and older, if they have at least 25 years of insurance experience for men, 20 years for women, a monthly compensation payment of up to UAH 500 is paid within the average salary in Ukraine, from which insurance is paid contributions and which is taken into account for the calculation of pensions for 2019 (UAH 9,205), and from March 1, 2021 – within the average salary (income) in Ukraine, from which insurance premiums are paid and which is taken into account for the calculation of pensions for 2020.

In this case, these persons who receive a pension granted in accordance with the Law №1058, taking into account the length of service, men 25 years, women – 20 years of service, in which the amount of pension benefits including allowances, increases, additional pensions, targeted cash benefits, the amount of indexation, monthly compensation in case of loss of a breadwinner due to the Chernobyl disaster, other surcharges to pensions established by law (except pensions for special services to Ukraine), does not reach UAH 2,600, such persons receive a supplement to the pension in the amount not enough of the specified size (resolution of the Cabinet of Ministers of Ukraine of 01.04.2020 № 251). From July 1, 2021 for persons who have reached the age of 75 before reaching the age of 80, whose monthly pension benefits include allowances, increases, additional pensions, targeted

cash benefits, indexation amounts, monthly compensation in case of loss of a breadwinner due to Chernobyl catastrophe, other surcharges to pensions established by law, does not reach the average salary (income) in Ukraine, from which insurance premiums are paid and which is taken into account for calculating the pension for 2020, a monthly compensation payment of up to UAH 400 will be set within the specified amount.

These persons, who receive a pension in accordance with the Law №1058, have insurance experience of men 25 years, women 20 years, and in which after establishing the above monthly compensation payment, taking into account all increases, allowances and other pension supplements (except special merit pension) before Ukraine) does not reach UAH 2,500, such persons will be provided with a supplement to the pension in the amount insufficient to the specified amount (Resolution of the Cabinet of Ministers of Ukraine of 16.09.2020 № 849 “Some issues of increasing pension benefits for certain categories of persons in 2021 year and beyond”).

3. The maximum amount of pension

Max may exceed ten times the subsistence level established for persons who have lost their ability to work (part three of Article 27 of Law 1058). In 2021: from January 1 – UAH 17,690.00, from July 1 – UAH 18,540.00, from December 1 – UAH 19,340.00. This maximum pension limit (monthly lifetime cash benefit) does not apply to pensioners whose pension (monthly lifetime cash benefit) is granted before the entry into force of the Law of Ukraine “On Measures to Legislatively Reform the Pension System” of 08.07.2011 № 3668-VI, if until October 1, 2011.

4. Calculation of insurance experience

When determining the amount of pension, the value of the value of one year of insurance experience at the level of 1% is used. For example, if you have 35 years of insurance experience, the pension is set at 35% of the earnings determined for calculating the pension.

Enrollment of a month of work in the insurance period as a full month is subject to payment of insurance premiums for the relevant month of work in the amount not less than the minimum insurance premium.

The minimum insurance contribution is calculated as the product of the minimum wage and the amount of the single contribution to the obligatory state social insurance established by law (22%) for the month for which wages (income) are accrued.

In 2021, the minimum insurance premium is: from January 1 – UAH 1,320, from December 1 – UAH 1,430 (Article 8 of the Law of Ukraine “On collection and accounting of a single contribution to compulsory state social insurance”, Article 8 of the Law of Ukraine “On The state budget for 2021”).

At the same time, it should be noted that from January 1, 2021 the submission of quarterly (instead of monthly) unified reporting on the single contribution to the obligatory state social insurance and personal income tax is introduced within the deadlines set by the Tax Code of Ukraine. 40 calendar days following the last calendar day of the reporting quarter. In order to ensure the timely appointment of a pension in the appropriate amount (taking into account the last months of work and wages) is currently working on providing the single contributor (employer) information on the single contribution for the period before the date of application for a pension without waiting for the end of the quarter.

5. Calculation of earnings

When calculating earnings to determine the amount of pension in 2021, the average indicator of the average salary in the country from which insurance premiums were paid will be used for the three years preceding the application for a pension, ie for 2018–2020 (this figure will be known in March).

In the period before the determination of this indicator, the average indicator of the average salary, which was taken into account in the previous, 2020 (UAH 7,763.17), will be used when assigning pensions. After determining the average salary for 2018–2020, all pensions granted on applications from January 1, 2021 will be automatically recalculated taking into account the new average salary with additional payment of the uncollected amount of pension from the moment of its appointment.

Note: When calculating pensions granted before January 1, 2021, the following indicators of the average salary were used: for those appointed before 31.12.2017 inclusive – UAH 4,888.83 (UAH 3,764.40 x 1.17 x 1.1); in 2018 – UAH 5,377.90; in 2019 – UAH 6,188.89, in 2020 – UAH 7,763.17 (Article 40 of the Law № 1058) [6].

6. Conditions of retirement by age

An old-age pension is granted subject to two conditions: reaching the statutory age and having the required length of service.

To retire in 2021 after reaching the age of 60 men and women 59 years 6 months (from April 1, 2021 – 60 years) must have insurance experience of at least 28 years. If a person does not have the required length of service at the time of reaching retirement age, he or she will be able to retire later, after reaching 63 or 65 years of age.

In particular, if at the time of reaching the specified retirement age a man of 60 years or a woman of 59 years 6 months (from April 1, 2021 – 60 years) insurance experience from 18 to 28 years, a person will be entitled to an old-age pension after reaching 63 years age.

If a person has insurance experience of 15 to 18 years, the right to receive an old-age pension will be exercised only after reaching the age of 65 (parts one and three of Article 26 of Law № 1058).

The length of insurance, which gives the right to receive an old-age pension, is determined on the date of reaching retirement age. Therefore, in the absence of the required length of service on the date of reaching retirement age (in particular, 60 years), a person can complete it and apply for a pension (or assign a pension of 63 or 65 years).

In case of slight insufficiency of the required length of service for the purpose of pension, you can take the opportunity to pay under the agreement on voluntary participation in the system of compulsory state social insurance a lump sum of the single contribution for the previous period (starting from January 1, 2004). Mandatory state social insurance, when she did not work and for which a single contribution was not paid. In this case, the amount of the contribution to be paid may not be less than the minimum contribution at the time of conclusion of the contract, multiplied by a factor of 2.

Based on the minimum amount of the single contribution, which is expected to be paid in 2021, the minimum amount of contribution for 1 month of insurance under the voluntary participation agreement will be: from January 1 – UAH 2,640, from December 1 – UAH 2,860.

7. Indexation of pensions

Automatic (for all pensioners without their application) annual increase (indexation) of pensions in 2021 should be carried out by increasing the average wage (income) in Ukraine, which is used to calculate pensions, by a factor corresponding to 50% of consumer price growth for the previous year and 50% of the growth rate of the average salary from which insurance premiums were paid for the three calendar years preceding

2021 (2018–2020), compared to the three calendar years preceding 2020 (for 2017–2019), (part two of Article 42 of the Law № 1058).

The specific size and procedure for such an increase will be determined by the decision of the Cabinet of Ministers of Ukraine (according to preliminary calculations, such a coefficient will be approximately 1.1).

Law № 1058 does not specify when pensions are indexed, but the Procedure for its implementation, approved by the Cabinet of Ministers of Ukraine dated 20.02.2019 № 124, stipulates that it is held annually from March 1.

8. Recalculation of pensions for working pensioners

Pensioners who continued to work after the appointment (recalculation) of pensions and acquired at least 24 months of insurance experience, have the right to apply to the territorial offices of the Pension Fund of Ukraine with a request for a recalculation of pensions. The calculation of the insurance period entitling to recalculation of the pension is carried out not earlier than the day following the day on which the insurance period was calculated during the appointment (preliminary recalculation) of the pension, according to the data available in the register of insured persons of the State Register of Compulsory State Social insurance [3].

It should also be noted that the introduction from the beginning of 2021 of a single quarterly reporting on the single contribution and personal income tax (instead of monthly) will affect the timing of applications for pension recalculation and its implementation. After all, data on insurance record and salary in the register of insured persons will be displayed no earlier than the middle of next quarter. At the time of applying for recalculation, as it was before, the register of insured persons may not contain information that the person has worked 24 months of insurance experience, in connection with which the Pension Fund will refuse to accept applications for recalculation of pensions and recommend later, when such information is displayed in the specified register.

Regarding the automatic recalculation of pensions from April 1, which is carried out subject to 24 months of insurance after the appointment (preliminary recalculation of pensions) as of March 1, this recalculation will continue to be carried out without the pensioner on the most favorable terms, if taking into account seniority after the appointment (recalculation) of the pension, or taking into account the length of service and salary after

the appointment (recalculation) of the pension (paragraph five of the fourth part of Article 42 of the Law № 1058).

In 2021, automatic recalculation of pensions, according to the Ministry of Social Policy, provided at the request of the Federation of Trade Unions of Ukraine, taking into account the deadlines for quarterly reporting on the payment of a single contribution, will be held in May-June, with the date of recalculation from April.

9. Increasing the pension in connection with the growth of the subsistence level

During 2021, such an increase in pensions was carried out twice: from July 1 and from December 1. Pension payments, the amount of which is calculated in accordance with the law based on the subsistence level for persons who have lost their ability to work, are subject to increase. At the same time, the increase in the minimum pension and the supplement to the pension for overtime is carried out only for non-working pensioners. For pensioners who continue to work, the increase in these payments (minimum pension and increase for overtime) will be made after their dismissal, based on the subsistence level for disabled people at the time of dismissal.

The subsistence level for persons who have lost the able-bodied population does not increase, but remains in the previously determined amount of increase (allowance) to pensions, in particular: children of war (UAH 66.13); persons living in mountain settlements (the amount of pension increases by 20%); for dependents (UAH 150.00 – to pensions granted in accordance with the Law № 1058); citizens who were unjustifiably subjected to political repression and subsequently rehabilitated – in the amount of UAH 54.40, and members of their families who were forcibly relocated – UAH 43.52.

When researching the issue of pension insurance, it is worth paying attention to the problem of distribution of insurance premiums for pension insurance between the employer and employees. According to some foreign experts, in order to maintain and increase the competitiveness of enterprises in the world market, it would be appropriate to redistribute the funding of pensions to all pension payers equally. In particular, countries with developed market economies have removed part of the burden of financing pension benefits from enterprises through the introduction of a funded pension system through mandatory and voluntary pension insurance. This funding was transferred to the working population.

With the reform of the pension system in Ukraine, the main functions of state regulation in the field of pension provision play an important role.

State supervision and control over the implementation and observance of the law by all subjects of the pension system is performed by the control function of state regulation. The regulatory function establishes certain rules through laws and regulations for the pension system. The social function involves state regulation of socio-economic relations, providing social guarantees. The formation of appropriate areas that can effectively influence the activities of participants in the pension system and stimulate its development in the right direction in society performs a stimulating function of state regulation in the field of pensions.

Mechanisms of state regulation of financial support of the pension system are effective if they comprehensively take into account the peculiarities of self-reproduction, self-development and self-regulation of the pension system. Improving their efficiency involves the development of self-regulatory processes, ensuring an organic combination of centralized management and independence of subsystems.

Priorities for further development of the pension sphere should include:

1. Definition of the purposes of pension system and strategy and the concept of development of its separate components.
2. Unification and codification of the regulatory framework in the pension sphere.
3. Directing pension expenditures to the development of human potential, improving its quality as a basis for economic growth and ensuring the competitiveness of the national economy.

Given that making effective management decisions without causation and understanding of forecast trends is quite difficult, given the large number of elements and relationships both within the pension system and in the external context, they were grouped into appropriate blocks and related to the main directions of development of the pension system, namely:

- formation of a healthy business climate in the country, creating conditions for the return of migrant workers;
- diversification of sources of financing the pension insurance system;
- de-shadowing of incomes and, accordingly, reduction of taxation of legal business;

Chapter «Economic sciences»

- creating conditions for the formation of pension rights of insured persons in the required amount;
- increase in the size of the single social contribution;
- strengthening the insurance principles of pensions;
- improvement of the entire system of realization of citizens' pension rights;
- elimination of the right to early retirement;
- establishment of a single retirement age for all – 60 years;

Refusal to try to raise the retirement age until life expectancy reaches the level of developed countries.

This scheme makes it possible to understand the purpose of the mechanism of state management of the pension system of Ukraine, which is manifested in its real external influence on the pension system to solve its development problems, ensure its sustainable operation and give it a given state.

Appropriate to ensure optimal conditions for the functioning of the pension system is to apply a comprehensive approach to the formation of its own national model of state regulation of financial security of the pension system, ie mechanisms, taking into account the political, economic and social development of the state. The above research provides grounds to propose the following set of methods for improving the mechanisms of state regulation of financial support of the pension system:

a) in the field of economics: the formation of market property relations; introduction of market self-regulation; reducing the level of shadowing of the economy; improving budget relations; formation of the institution of private property; creating conditions for the implementation of the optimal model of the pension system;

b) in the field of politics: to optimize the social development of Ukrainian society, to approve updated constitutional mechanisms, regulations that will improve the mechanisms of state regulation of financial support of the Ukrainian pension system, as well as change the system of power relations;

c) in the field of social relations: improvement of social mobility processes; ensuring social security, as well as the formation of a new social structure of Ukrainian society in the crucial role of the middle class.

Summarizing the above, we can conclude that to improve the mechanisms of state regulation of financial support of the pension system of Ukraine

should take these measures, and the comprehensive application of political, legal, economic mechanisms will maximize the goals of pension policy. Thus, the objective basis for regulating the financial support of the state pension system is the development and implementation of the Strategy for the development of the model of state regulation of the pension system. The formation of such a strategy, determining the optimal structure of goals, specifying the management subsystem in the pension system, analysis and control of management activities will contribute to the functioning of an innovative model of state regulation of financial support of the pension system of Ukraine.

4. Foreign experience in reforming the pension system

Today, most European countries have long since switched to a three-tier pension system, which has proven successful. In Ukraine, the full implementation of the second level of the pension system is planned only from 2021. We have already written about government reform plans in previous publications.

The main reasons for the insufficient development of private pension provision in Ukraine include:

- legislative unresolved issues of certain non-state pension market activities;
- low level of public confidence in private pensions, the banking system and other financial institutions;
- Insufficient interest of employers in financing non-state pension programs for employees;
- low financial level of citizens' ability to participate in the private pension system;
- limited choice of financial instruments suitable for investing pension funds in them, due to the lag of capital market development from the needs of institutional investors;
- low level of explanatory work on the content and role of the funded pension system in society and insufficient funding.

The integration of Ukraine's pension system into the European and world pension system can take place in certain areas. Ukraine's experience of its closest neighbors is valuable. The countries of Eastern Europe and the Batiks have followed this path since the 2000s.

The first level is the solidarity system. It provides a basic income for a person after retirement. The amount of the pension at the first level can be fixed, or depend on the amount of contributions and length of service (these two basic indicators will mainly determine the amount of pension for Ukrainians).

The second level is the obligatory accumulative system of state pension insurance. Each person has an individual pension account, which is formed on the basis of pension contributions of the employee and the employer.

Reforming the pension system in Ukraine has become an urgent problem. The actions of state governments at various stages of the crisis in this system were not such as to weaken the crisis, much less eliminate it. The changes that have taken place in this area have had the character of situational reactions rather than systemic reform. It is clear that in order to implement such a reform, it is necessary to generalize the basics of the functioning of the pension systems of those countries in which they have proved to be the most stable in the face of external challenges. In addition, Ukraine should build a pension system that would be built-in, could cooperate on the same basis with the pension systems of advanced countries.

The period of formation of the state pension insurance provided simultaneous development of solidary and accumulative pension systems. For example, in the Nordic countries (Denmark, Finland, Norway and Sweden), as well as in the Netherlands, Switzerland and most Anglo-Saxon countries (except the United States), universal pension systems have been introduced that guarantee a minimum fixed income. At the same time, the source of pension payments was tax revenues to the budgets of these countries. In contrast to these countries, in other European countries (Germany, Austria, Belgium, France, Italy, Spain), as well as in the United States, pension systems have developed on the principles of social insurance. In such circumstances, pensions were intended to replace lost earnings, and the source of their payment was insurance premiums of employees and employers [5].

There are still significant differences in the organization of state pension insurance in different countries, but they do not stand in the way of effective implementation of its tasks. This indicates that the goals of state pension insurance can be achieved in different ways. They depend, first of all, on the

peculiarities of the historical development of different states, as well as on specific views on the role of the state in ensuring social protection.

To determine the main directions of integration of Ukraine's pension system into the European and global pension system, it is first advisable to consider the structures of pension systems of leading countries in which these systems were the most stable in economic crises. Regarding the structure of the pension system, the question arises whether or not there is an accumulation fund for the accumulation of contributions at the second mandatory accumulative level, the existence of which is provided in Ukraine by the registered bill № 2683. Another important issue is the functioning of the primary contribution institution. (Treasury) at the second level of pension provision – also based on the experience of such countries.

Another component in Ukraine's integration into the world pension system is the introduction of new technologies, the creation of modern information and technical support system of the pension system, which will reduce the administrative functions of public administration in the process of registration and accounting of pension contributions. This concerns the possibility of introducing a so-called automatic pension record in our country. The introduction of the auto-recording system is possible simultaneously with the introduction of the accumulative level of pension provision, but it is also possible later. The essence of this technology is that “all employees automatically become members of the funded pension system of the second level at the time of introduction of auto-recording. The employer and (in most cases) the state must pay the first statutory pension contribution to their individual pension accounts. small (1-2% of gross salary for the employer and a small bonus from the state)” [1].

It is clear that the third cumulative level provides for the possibility of leaving such a system, but the difference in its introduction is that in countries still introduced, there is almost no difference between the second mandatory and third voluntary cumulative pension level, as government intervention in The functioning of these levels is provided only in the part of the existence of the system of auto-recording and the legal requirements for citizens regarding the obligation of pension insurance.

The automatic retirement system was first introduced in Australia in 1992, then in New Zealand, Israel (the relevant legislation was adopted here in 2007), the United Kingdom (introduced auto-registration in 2012) in

the USA. From January 1, 2019 it will operate in Georgia, Lithuania, from 2018 in Denmark, from 2020 it will start in Ireland. “In the UK, according to V. Melnychuk, “since the introduction of automatic enrollment, the share of employees who actively participate in pension savings programs has increased from 55% in 2012 to 84% in 2017” [9].

It is clear that the second and third tier pension insurance differ in the subject of insurance. At the second level, the insurance premium is paid by the employer (or both the employer and the employee in the proportions established by law), and at the third level – only the employee. In the UK, with the introduction of the system, “327,000 employers have opened an account with NEST” [1].

There are other data as of the end of 2019, which indicate that the amount of accumulative assets in the world is 40.2 trillion dollars, the world’s leading US countries – 24.7 trillion dollars, Japan – 3.12.9 trillion dollars, Great Britain – 2.9 trillion dollars (remained unchanged, we can assume the impact of the political situation in the country in connection with the change of government on the economic development of the country), the Netherlands – 1.5 trillion dollars, Switzerland – 0.9 trillion dollars, Ukraine – 106 million dollars [8].

Recently, in many countries around the world, the issue of reforming the pension system and modernizing the role of the state in this system is especially relevant. The reason for this, among other things, are the problems of managing the finances of pension systems. The ratio of pension benefits to GDP in developed countries has reached critical values. In many developed countries, the ratio of pension expenditures to GDP exceeded 10%, which caused significant problems for the economy. According to statistics from the International Labor Organization, the percentage of GDP spent on state pension insurance payments in most countries is expected to increase and by 2050 will be about 15% of the total GDP of these countries.

In general, the growth of assets in less than two years amounted to 10.13%, and in Ukraine – 19.81%, which confirms, albeit not in real terms (excluding inflation, cost of living) the ability to manage assets (albeit in small quantities) accumulative pension funds. However, in order to increase the cost of investment, management companies need to use the world’s experience in asset placement. The placement of pension assets of private pension funds in the world is most common in: government bonds;

corporate and municipal bonds; shares and certificates of private investment funds; real estate; Cash and cash equivalents.

Analyzing the above, we can conclude that most foreign countries use multi-component pension systems, which are based on the accumulative principle. In our opinion, the main positive features of the accumulative system of state pension insurance are the ability to strengthen the motivational factors of the population to participate in pension insurance. In this system, there is a much closer link between the contributions made and the pension benefits received than in the solidarity pension system, which makes it possible to weaken paternalistic sentiments in society. The development of non-state pension provision can also reduce the burden on the state pension insurance in the future and supplement it with new pension insurance schemes that are not available to the population in the mandatory state pension insurance. According to foreign experience in the implementation of pension reforms, their essence was the redistribution of responsibilities between the state, social partners and individuals [3].

Summing up, it should be noted that an important condition for reforming the pension insurance system in Ukraine can now be foreign experience in organizing supplementary pension systems, when several sources of income are formed after retirement. The existence of such additional pension income in various forms both in the EU and in other countries shows the effectiveness of the approach, when the financial burden of social protection in the country is shared between the state, the employee and the employer.

Supplementary pension insurance systems mainly use the accumulative principle as a basis for financing and can be implemented in various forms, both in the form of state pension provision pension programs and in the form of occupational pension insurance schemes.

The main advantage of the multi-component pension system is the ability to clearly correlate the size and timing of contributions with the size of future payments, as well as the ability of the insured person to personally monitor the retention of funds in individual savings accounts. This will make it possible to optimize financial flows related to the social protection of the disabled and, in the long run, to solve macroeconomic problems.

Although private pension expenditures in the post-Soviet countries of Central and Eastern Europe are much lower than in the Anglo-Saxon countries, private pensions have significant potential for solving social

problems and are an effective tool for influencing investment markets. In this context, in the context of pension reform in Ukraine, the development of private pension provision will create conditions for optimizing the functions of state pension insurance in accordance with the tasks it performs in a market economy country at the present stage of its development.

Therefore, based on the world's experience in asset management and investment, it can be argued that the correct diversification of deposits can or strengthen the employee can count on an additional corporate pension. «In addition, in Germany from pension insurance to medical examination».

5. Directions of pension reform in Ukraine

Given the experience of countries around the world on the functioning of pension systems, the integration of Ukraine's pension system into the European and global pension system can take place in several directions. Each of these areas has one or another way of solving issues related to the implementation of integration processes, implementation of European social standards, etc. (Table 1).

Integration into global processes will not give grounds to slide back to the Soviet pension system. In addition, the inclusion of Ukrainian investment companies in international economic relations, Ukraine's entry into the international financial market will allow for the actual implementation of production standards.

In particular, in Ukraine, as in many other countries around the world, there is a reduced fare for this category of the population. These are in fact state or municipal programs with different conditions without cost measurement of the service. However, travel in non-social (expensive) transport can be "insured" with the participation of voluntary contributions in the future to receive such a service on preferential terms. In addition, this type of pension can include long-term health insurance (benefits after retirement). That is, it can be investing in health care facilities, health and recreation facilities, with the guarantee of benefits in retirement. In our opinion, it can also be the services of nursing homes, receiving additional services for single elderly people, and so on.

It will also stimulate compliance with international rules of construction and management of the financial market, which will promote the development of the Ukrainian system, bring it to a higher level of development, according to

Proposals for Ukraine ‘s integration into the pension system of the world’s leading countries

Direction of integration	Ways to implement directly
Compliance with the structure of the system	Existence of a state institution for deposit administration. Lack of a state institution for asset management at the accumulative levels of pension provision. Lack of savings fund as a centralized accumulator of funds
Information and technical ensuring the pension system	Introduction of an automatic recording system at the second level of pension provision. Eliminate differences in the management of the second and third levels of pensions
Asset management	Correspondence of directions of investment of insurance accumulative funds to the best world practices. Creating opportunities for pension investments in land and real estate. Development of the financial market of Ukraine. Changing the investment climate in Ukraine, reduction its to world standards in terms of investment guarantees
Integration into the world Investment space	Opportunity to invest non-state savings funds in the world’s leading companies
Creating the fourth (fifth) level of pension software	Creating a legal framework for investing in health care facilities, facilities rest, rehabilitation with the guarantee of benefits at retirement age

the theory of crisis management, or even lead to its destruction. The success of the system depends on its ability to store and multiply deposits for a long time.

It is necessary to dwell on the use of world experience on the possibility of introducing the fourth (fifth) level of pension provision in Ukraine, which can take various forms. This level is non-capital in nature, not financial. It is provided by providing certain social services to retirees.

Thus, based on the experience of advanced countries, which have not formally declared the presence of the fourth (fifth) level of pension provision, we can borrow some forms of its manifestation. In Germany, in particular, although there are only three levels of pension provision under the law, the second and third levels take different forms to ensure a decent old age for citizens. As an example, «in large German companies, such as Mercedes, Airbus or Siemens, which economy». Such a system will be independent of demographic crises.

The integration of Ukraine's pension system into the European and world pension system can take place in certain areas, namely:

- compliance of its construction with successful pension systems of the world;
- information and technical support;
- compliance with the directions of investing insurance savings;
- the possibility of integration into the world economic space by investing in leading companies in the world;
- development of the fifth level of pension provision.

For each area it is necessary to implement a set of measures such as ensuring the existence of a state institution for the administration of deposits; lack of accumulation fund as a centralized accumulator of funds; introduction of an automatic recording system; compliance of the directions of investment of insurance savings funds with the best world practices, in the legislation to establish the possibility of pension investments in land and real estate; the possibility of investing non-state savings funds in the world's leading companies, etc.

6. Findings

The current pension system does not adequately meet the needs of retirees, as in recent years in Ukraine there has been a significant deficit of the PFC budget, reduction of own revenues to the state budget, evasion of taxpayers from paying insurance premiums, large pensions, shadow wages. Each country has its own national model of state regulation of the financial provision of the pension system, which effectively manages pension funds. Also, for the successful formation and development of the pension insurance system, which plays a key role in shaping the national pension model, the legislative framework of pension insurance is of great importance.

Further development of private pension provision can reduce the burden on the state pension insurance in the future and supplement it with new pension insurance schemes that are not available to the population in the mandatory state pension insurance. The intensification of the activity of the system of non-state pension funds and the accumulative pension fund will become a significant source of investment resources in the economy of Ukraine and will contribute to ensuring its financial security.

The private pension system plays an important role in providing for the population. It is a safe, and in most cases – a preferential means of ensuring a decent standard of living after working. Another, no less important function of the private pension system is that it is a source of long-term investment necessary for the economic development of the country.

Expected results of the pension reform and forecast indicators:

– Achieving pension expenditures at the level of 12 percent of gross domestic product and ensuring the minimum level of pension provision at the level of 40 percent of earnings.

– Annual recalculation of pensions for 11 million retirees.

– Attracting 132 thousand employees to the accumulative system of mandatory occupational pension provision.

– Tasks for the current year.

– Development and submission to the Cabinet of Ministers of a bill on the introduction of a funded occupational pension system.

– Analysis of the implementation of state policy in the field of administration of a single contribution to the obligatory state social insurance. Preparation of proposals to improve the quality of single contribution administration, taking into account the need to overcome the negative economic consequences caused by the COVID-19 coronavirus pandemic.

– Improving the mechanism of indexation of pensions [1].

7. Conclusions

Given the world's positive experience, it is safe to say that the intensification of the system of private pension funds and funded pension funds will be a significant source of investment resources in Ukraine's economy and contribute to its financial security.

You can develop a funded pension system by:

– improving the financial market infrastructure, developing corporate governance and financial instruments;

– creation of a software and hardware complex for the functioning of the accumulative pension system;

– improvement and unification of tax legislation on the functioning of non-state pension provision;

– increasing the institutional capacity, level and quality of professional training of the subjects of the pension system;

- improving the system of electronic reporting of employers and the introduction of monthly reporting of policyholders;
- protection of the rights of institutional investors [2].

In addition, improving the information support and transparency of this system is a key issue in the strategy for the development of the pension system in Ukraine.

Despite the rather complex and ambiguous assessment of the legal form of existence of private pension funds, all the mechanisms provided for in the legislation on these entities are aimed primarily at preventing the misuse of participants' pension funds. In our opinion, the model of private pension funds chosen by the legislators should justify itself and realize its social purpose.

The concept of pension provision, which provides for a gradual transition from a three-tier to a two-tier pension system, will contribute to the formation of a highly efficient financially balanced pension system that will encourage retirees to save and employers to increase pension contributions. In addition, it will allow to accumulate additional investment resources for stable economic development, increase pensions, contribute to the formation of a new paradigm for national financial interests.

References:

1. Demografichni ta finansovi peredumovy pensiinoi reformy v Ukraini: prohnoz – 2050. Analitychno-doradchyi tsentr blakytnoi strichky. Retrieved from: <http://brc.undp.org.ua/img/publications/DemographyPensionFULLUKR1.pdf> (in Ukrainian)
2. Martseniuk-Rozaronova O. V., Ozvenchuk O. A. (2018). Stan ta perspektyvy rozvytku nederzhavnogo pensiinoho strakhuvannia v Ukraini [Status and prospects of development of private pension insurance in Ukraine]. *Elektronne naukove fakhove vydannia "Derzhavne upravlinnia: udoskonalennia ta rozvytok"*, no. 10. Retrieved from: <http://www.dy.nayka.com.ua/?op=1&z=1319> (in Ukrainian)
3. Martseniuk O. V. (2020). Nederzhavne pensiine strakhuvannia v Ukraini: stan, problemy ta perspektyvy rozvytku [Non-state pension insurance in Ukraine: state, problems and prospects of development]. *The scientific heritage*. Budapest, Hungary, no. 46, ch. 8, pp. 45–55. Retrieved from: <http://tsh-journal.com/wp-content/uploads/2020/05/VOL-8-No-46-46-2020.pdf>
4. Martseniuk O. V. (2021). Suchasni tendentsii rozvytku strakhovoho rynku Ukrainy v umovakh yevropeiskoi intehratsii [Current trends in the development of the insurance market of Ukraine in the conditions of European integration]. *Colloquium-journal*, no. 3(90), część 4, pp. 38–47. Retrieved from: <http://www.colloquium-journal.org/wp-content/uploads/2021/01/colloquium-journal-390-chast-4.pdf>

5. Ofitsiinyi sait Lihy strakhovykh orhanizatsii Ukrainy [Official site of the League of Insurance Organizations of Ukraine]. *uainsur.com*. Retrieved from: <http://uainsur.com> (in Ukrainian)

6. Ofitsiinyi veb-sait Ministerstva sotsialnoi polityky Ukrainy [Official website of the Ministry of Social Policy of Ukraine]. *mlsp.gov.ua*. Retrieved from: <http://www.mlsp.gov.ua> (in Ukrainian)

7. Ofitsiinyi sait Natsionalnoi komisii, shcho zdiisniuie derzhavne rehuliuвання u sferi rynkiv finansovykh posluh [Official site of the National Commission for State Regulation of Financial Services Markets]. *nfp.gov.ua* Retrieved from: <https://nfp.gov.ua> (in Ukrainian)

8. Ofitsiinyi veb-sait Pensiinoho fondu Ukrainy [Official website of the Pension Fund of Ukraine]. *pfu.gov.ua*. Retrieved from: <http://www.pfu.gov.ua> (in Ukrainian)

9. Pensiina reforma. Ukrainske natsionalne informatsiine ahentstvo. Retrieved from: <https://pension.ukrinform.ua> (in Ukrainian)

**DIGITAL TECHNOLOGIES AS THE BASIS
FOR DEVELOPMENT TOURISM ACTIVITIES IN UKRAINE**

Lyudmila Novitska¹

DOI: <https://doi.org/10.30525/978-9934-26-193-0-7>

Abstract. The scientific article is devoted to the study of possibilities of digitalization of the tourism industry. It is substantiated that tourism in Ukraine is a sphere of socio-economic complex, which in many countries has become a major rapidly developing industry. It serves as a source of foreign exchange earnings and promotes employment of the population; increases the contribution to the balance of payments; contributes to the diversification of the economy through the development of tourism infrastructure; increases the attractiveness of the country as an area of business and business cooperation; creates incentives for the inflow of foreign capital into the national economy.

It is proved that tourism needs new approaches to the organization and management, including the use of modern digital technology, which can significantly improve the quality and efficiency of the tourist product. It is established that in the conditions of total digitalization digital transformation of business is the main condition for the survival of companies in the tourism sector in competition. The main driver of these changes is the consumer, they and their needs dictate the conditions in the digital services market.

It is noted that the development of digital economy forms the main trends in the tourist market around the world, particularly in Ukraine, the most important of which are: the globalization of tourism business, the active development of transnational Internet resources, the convergence of tourism service providers and consumers, the emergence of new distribution channels of tourism product, the massive access of offline companies to the Internet, changing consumption patterns, the formation of an individual approach in organizing travel, etc.

¹ Candidate of Pedagogical Sciences,
Associate Professor of the Department of Mathematics,
Physics and Computer Technology,
Vinnytsia National Agrarian University, Ukraine

It is established that the latest digital technologies include: big data technologies, cloud services, internet of things, blockchain technologies, mobile technologies and social networks, digital technologies and devices, virtual technologies and others.

It is substantiated that for the managers of travel industry companies the use of digital technology allows: increase the investment attractiveness of the tourist enterprise; control labor productivity and efficiency of business processes; quickly detect “weak points” in the management of processes; increase the availability of tourist services, quality of service and provision of services.

It is proved that the use of digital technology increases the safety and quality of tourist services.

1. Introduction

The modern industry of tourism in Ukraine develops dynamically enough, though from time to time experiencing moments of crisis due to political, economic and epidemiological aggravations in the country.

As a result of changes in the economic vector of Ukraine the tourism industry is increasingly positioning itself as a commercial sphere, able to organically fit into the socio-economic complex of the country. Analyzing the experience of European countries, and in the case of transferring such experience to the domestic cultural and economic soil, the tourism sector will be able to make a significant contribution to the budget, will be a reliable source of foreign exchange earnings, stimulating the inflow of foreign capital into the national economy, can provide employment, increase the attractiveness of the country. as a business sphere, etc.

Given the recent events that have significantly affected the global tourism industry, tourism needs new approaches to the organization and management, in particular with the use of modern digital technologies that can significantly improve the quality and efficiency of the provision of the tourist product.

It should be noted that the development of modern digital technologies in tourist activities depends mainly on factors of internal and external environment. These factors interact with each other and depend on the specific socio-economic conditions of development of the state and the region at the macro level, as well as the enterprise at the micro level.

At the macro level, external reasons for the development of digital technology in tourism are formed. Conventionally they are divided into two groups:

1. Statistical – natural and climatic, geographical, cultural and historical.
2. Dynamic – political and legal, socio-demographic, financial and economic, logistical.

The foundations of tourism at the regional and national level are natural resources, which include natural landscapes, volcanoes, seas, rivers, mountains, mineral waters, healing springs, climate. Also, cultural and historical reasons play a huge role in the development of tourism activities: historical monuments, museums, memorials, culture and customs of local inhabitants of the regions, etc. Tourist activities are mainly aimed at natural-climatic and cultural-historical factors. Unconstructive approaches to the development of territories and the wrong approach in the exploitation of natural and cultural heritage can lead to the decline of tourist potential.

Dynamic factors also have a great impact on the development of tourist activity. Political instability of the region, protracted crises in the economy, military conflicts, increasing unemployment, etc. have a negative impact on the level of tourism development. The socio-demographic factor is more significant in this group. This factor is characterized by such indicators as living standards of the population, degree of well-being, demography, employment level, level of education and culture, urbanization, etc. Such factors as the level of health care system activity, crime rate, as well as the environmental situation in the region can be attributed to separate social factors. The material and technical factors of tourist activity development are the tourism infrastructure, i.e. hotels, hostels, stores, roads, banks, communication, etc.

Internal factors of tourism business development play a huge role in the process of implementing the digital economy. These factors are formed at the micro level of tourism firms. Internal factors include: the policy of digitalization, the strategy of tourist activity of companies, the introduction of the latest digital technologies, as well as their development, the support of innovation from the management of companies, the high level of financial capabilities of companies, as well as organizational and technical readiness to implement and develop innovations.

In conditions of rather fierce competition in the tourist market the main task for the Ukrainian tourist enterprises is the formation of competitive advantages

and under such conditions the way to improve their position in the competition is the active use in their practice of modern information technology – full automation of the process of placing orders for tourist services, the use of direct channels of communication with partners-tour operators; the use of electronic booking systems of tours, e-tourism system, the use of electronic communication with partners – tour operators. [1, p. 119].

2. Analysis of recent studies and publications

The issue of tourist industry development in the digital economy is not new and is studied by many scientists and researchers, such as O.M. Golovnya, P.I. Zhezhnich, R.B. Kozhukhovskaya, E.V. Kozlovsky, T.V. Marusey, S.V. Melnichenko, M.M. Skopen, O.O. Soprunyuk, Y.V. Stavskaya, etc.

Among the publications devoted to the information support of tourist activity, the study by P.I. Zhezhnich and O.O. Soprunyuk [2] deserves special attention. The authors have successfully considered the dual role of information support in the work of tourist enterprises, which, on the one hand, is designed for effective interaction between the producer and consumer of tourist services, and on the other hand, allows to increase the efficiency of information processing within the tourist enterprise.

According to T.V. Marusey, the main tendencies of development of tourist industry in conditions of digital transformation of economy can be marked the following: globalization of tourist business; active development of transnational Internet resources; convergence of suppliers of tourist services and consumers; appearance of new channels of distribution of tourist product; mass access of offline companies to the Internet; change of consumption model; personification approach in travel organization; use of mobile applications [3].

S.V. Melnichenko covers theoretical and methodological bases and practical tools of information technology application in tourist business; the role and place of information technology in management and marketing of tourist enterprises are defined; recommendations on modification of organizational management structures of tourist enterprises and management system as a whole under the influence of information technology are given [4].

Global computer and Internet networks acquire great importance in tourism. Thanks to information technology will increase the effectiveness of marketing in tourism, the consumer will be able to quickly obtain

the necessary quality information about the tourist product without leaving home [5, p. 27].

The work of M.M. Skopenya focuses on the processes of automation of the firm's activities with the help of office programs, computer equipment used in the work of a travel firm, the creation of effective sites and servers of the travel firm on the Internet [6, p. 87].

Tourism is one of the leading and most dynamic sectors of the economy. A key factor in the development of the economy in modern conditions is the data presented in digital form. In this regard, digital technologies play a decisive role in ensuring the competitiveness of enterprises, industries and entire states.

Currently, tourism has entered a stage of its development at which information and timely transmission play a decisive role in all areas of tourism activities, with modern information technology in tourism becoming the most important factor in the economic growth of the industry. Information and technological progress today is not only the main factor in ensuring the effective functioning of the tourist market, but also the most important condition for the process of its sustainable development. Consequently, priority should be given to modern digital technologies which, thanks to their unique properties, will actively contribute to the dynamic development of all sectors of the tourist market [7, p. 61].

Thanks to modern Internet resources, notions of distance and territorial remoteness are increasingly being leveled. And that is why tourism, which a priori possesses a tool for demolishing spatial barriers, plays a great role. The tourism industry is a multidimensional phenomenon, equipped with many functions and therefore can become an area of multidirectional efforts and involvement of different professional groups.

The purpose of the article is to identify the main types of information systems and technologies that are used in the process of tourist activity and to identify their impact on the successful functioning and development of the tourist enterprise.

Digitalization is the introduction of digital technology in all areas of life: from the interaction between people to industrial production, from household items to children's toys, clothing, etc. It is the transition of biological and physical systems to cyberbiological and cyberphysical systems. The transition of activities from the real world to the virtual (online) world [8].

Digitalization has not escaped the travel industry. There are no segments of the travel business that have not been touched by it. Today it takes only a few minutes to plan a trip: instantly book a plane, find and rent an accommodation anywhere in the world, read a review of any restaurant. Modern technology has made it all accessible and brought it to a new level [3].

Nowadays, customers' desires and demands for the service have grown. Applications for mobile devices such as Skyscanner, Flightradar24, Booking, Airbnb, Couchsurfing, Maps.me. and others. and locality have taken independent travel to a new level: all the features of a small travel agency can now easily fit in your pocket. GPS and maps, currency calculator and city guide – the optimal set of applications helps plan trips and save time, money.

However, in today's world, people are increasingly worried about both money and time spent, so they need a quick fix for their needs, including travel and leisure. A quick solution to this problem can be offered by travel agencies (travel agencies, travel agents). At the same time we should note that the geography of travel and preferences of Ukrainians has greatly expanded. If in 90-s about 70% of all tourists in Ukraine chose Egypt and Turkey, now travel agencies should explore dozens of new directions, among which are exotic islands: Bali, Zanzibar, Maldives, Mauritius, Madagascar, Sri Lanka, and others. But if travel agencies cope with the diversity of destinations and their research, there are serious gaps in the digitalization of business [3].

Ukraine has a rather low level of use of digital technology and digitalization. In this regard, the government of the country, in the framework of the project “Ukraine 2030E – a country with a developed digital economy”, developed by the Ukrainian Institute of the Future, until 2030 intends to carry out a comprehensive digital transformation of social and economic activity in Ukraine. This requires the development of regulatory regulation of digital technologies, modernization of digital infrastructure, development and implementation of digital platforms and technologies in the main areas of the economy and public administration, personnel training and information security.

Therefore, the relevance of the use of digital technology by tourism enterprises is still higher than ever.

3. Internet technologies

Factors in the development of digital technology in the tourism industry include: an unlimited amount of information, allowing detailed information about the hotel or travel agency; round-the-clock access to information, allowing data to change depending on market dynamics; the breadth of audience coverage, allowing to serve customers remotely; interactive mode, providing information on the number of visitors for a certain period of time and the ability to calculate demand guided by their choice.

Currently, the Internet has become a powerful information system without borders. Its use in organizing tourism activities has several practical directions.

The first direction is the use of information capabilities of the Internet as a source of data for various kinds of research and analysis for the purpose of conducting tourism activities: obtaining information about the country, its history and culture, tourist potential, attractions, local traditions and customs, geographical and climatic conditions, currency exchange rates, etc. However, it should be noted that such information capabilities of the Internet are not only an advantage, there is a significant disadvantage – the need for a large amount of time to search for and process the necessary information.

The second direction of using the Internet is the creation of specialized sites that provide reservation and reservation services for tourist services like electronic reservation systems.

Creation of Internet sites is an important element in the marketing strategy of tourism enterprises. The site of a tourist enterprise can become a kind of a business card of the company and an advertising catalog of tours. The Internet site can be an important element in the organization of tourist activity itself, in particular to become a tool for expanding contacts with partners, to function as a reception of customer orders for the purchase of various tours. The audience of tourist Internet sites are mostly potential tourists who are looking for the necessary information in the global network to plan their trip.

Through the Internet, the customer with a web browser enters the travel company's website. Usually the website contains a catalog or a list of searchable tourist products offered by the travel agency or its partners. The website contains the necessary tools for entering and registering a variety

of information. Customers can choose and form orders for a certain tourist product, make payments via the Internet, get the necessary advice on the planned trip.

4. Mobile technologies and social networks in tourist activity

The functions of mobile applications differ little from those of websites, the main task of which is to present information about an enterprise, its products and services. The main difference between mobile applications is that they have much more opportunities to convey information to consumers. The cell phone is always with the user, and if it is connected to the Internet, its owner can always be interested in a specific commercial offer. The undoubted main advantage of mobile applications is the ability to work even without a connection to the network.

Mobile applications give a travel company a lot of advantages:

- increased sales;
- optimization of business processes and increased efficiency in decision-making;
- creation of their target audience;
- new sales and communication channels;
- increase in customer loyalty;
- centralized statistical data required for further
- additional competitive advantage over other similar enterprises.

Currently, experts highlight the following features of the mobile application market:

1. The growth of mobile advertising. The mobile advertising market is directly related to the mobile app market, and these markets are growing at a fast pace, being essentially related. The growth of mobile advertising budgets is a consistent and natural process, depending on the growth of mobile applications and competition in the market.

2. Growth of mobile consumption. In almost all developed countries the consumption of mobile services by the population is growing, the sale of smartphones and tablets, as well as the use of mobile traffic. Such changes in consumption have a significant impact on the development of the mobile application market.

3. Stimulation of the market by platform owners. Such giants as Google, Apple, Microsoft encourage mobile application developers through

competitions, creating more favorable conditions of cooperation. The goal of platform owners is the maximum number of applications for their platform and quality service for the user.

4. High budgets for development. The mobile app market is more promising in development compared to other software markets, since mobile app budgets have remained at a very high level for many years. Among the minor obstacles to the growth of the mobile app market, experts single out only two points: the complexity of payment and the lack of user awareness.

The complexity of payment for many users remains the main obstacle to the growth of the mobile app market, people do not yet fully trust mobile systems and do not want to leave their payment card data in the system. Smartphone owners, especially the adult audience, do not use many useful functions of the phone, and use it only for making calls and sending text messages.

Depending on the functions performed by mobile applications, they are conventionally divided into entertainment (multimedia), communication, navigation, reference, and applications. The main groups of mobile applications, which are used both by tourists and tourist enterprises are: navigation and maps, purchase of air tickets, hotel reservations, guides, translators, car rentals.

Google Maps is a mobile application that offers the user GPS navigation with voice guidance, diagrams of public transport routes, up-to-date information about roads (congestion, traffic jams). Designed for motorists, cyclists and pedestrians, the application integrates classic and satellite maps, on which you can include the display of internal diagrams of large buildings and panoramic photos of streets. The business directory will help you to find the coordinates of the desired hotel, restaurant, shopping and entertainment center or business.

Google Translate is the best translator, which “speaks” almost all the languages of the world. The most useful application for travel became after it received an offline version. In anticipation of a trip to a particular country, you can download offline dictionaries to your smartphone and easily avoid the difficulties of translation. Google Translate is constantly working on improving the voice module, so now, almost in real time, you can communicate with a person in different languages and understand each

other. For example, receiving a phrase in Ukrainian, the application in the buffer translates and immediately plays its English version.

Skyscanner is one of the best applications for buying airline tickets at the lowest price. In the program you can view the flights of many carriers, including low-cost airlines, for many months in advance, choosing the most reasonable price. Along with Skyscanner you can download a smartphone application such as Flight Track. It is designed for those who are always late to check in, forget the flight number, mix up dates and times. A few days before departure, the program will remind you of the start of the trip, will tell you when check-in and boarding begins, in which airport terminal it takes place. You can also see the layout of seats on the plane, a map of the terminal, etc.

Booking.com is a mobile version of the hotel booking portal of the same name. The application has already become a cult and is very popular among everyone who travels around the world. It allows you to easily and always at the best price to book a room at any hotel. The program has a database of more than a million accommodation facilities. In addition, every day there are special offers on Booking.com, where certain hotels offer accommodation at half price. Loyal users of Booking.com get additional discounts. The menu is available in many languages, including Ukrainian, and you can get room rates in hryvnas, dollars, euro or other currencies.

TripAdvisor is a mobile application that allows you to organize and make a perfect trip. The program has built-in maps, which allows you to quickly get on the ground and find what you need: hotels, restaurants, cafes, and historical and cultural attractions. TripAdvisor will not only mark them on the map and lay the route, but also show photos. In the database of the application the tourist can find more than 150 million reviews, which will help to choose only the best places to visit. A sticker with the logo of this application and the corresponding rating decorates the front door of many hotels, restaurants, bars, store windows, etc.

BlaBlaCar is an Internet platform with a mobile application for joint rides in a car. It is a service that connects drivers and passengers who would like to share the cost of medium- and long-distance trips. Drivers post routes and passengers choose them, and they travel together and share the cost of fuel. The program has thousands of driver profiles from which you can learn about the make of car the number of seats available, the cost of

transportation, and, most importantly, personal information about the driver and his contact information. The application is free and easy to use.

Sixt Rent a Car is a mobile application which allows you to rent a car in any country as Sixt rent-a-car stations are located almost all over the world. Additionally it is possible to order child seat installation depending on the age of children, GPS navigation etc. Regular customers of the company can get a corporate card allowing to make the renting procedure faster, get a discount till 20%, improve the class of a car, get miles and round-the-clock support in any country.

TripbyClick.Ukraine is a mobile app for travel in Ukraine that combines a social network like Instargam with a travel planner. The main interface of the program is a news feed with photos of users of the program from different parts of Ukraine. You can scroll through them, save them as bookmarks or add location to the route of your future trip. You can filter by topic. In his profile, the user can create a travel itinerary by adding the places of interest to it. You can also share photos from your trips with other participants, making sure to specify the location where the photo was taken. The app also has a system of rewards for travelers. You can get them for visiting a certain number of places, publishing, swearing from other users, etc.

Mobile applications created for smartphones and tablets are an innovative means of stimulating national and international tourism. The main advantages of their use can be considered: simplification of communication between the subjects of tourist activity, economic benefit and ease of use. Considering specifics of work of the tourist enterprise and current business priorities, mobile applications proved to be an effective marketing tool for attraction of new customers and convenient service for work with existing client base.

Customers now have the opportunity to form a tour of their own preference via the Internet: choose a hotel, time, way of travel, meal options and additional services. The main part of travel market participants prefer online booking technology, which is based on instantaneous display of real information on availability of free places at current rates with the possibility of their reservation. In practice, these two functions are often distinguished, as instantaneous booking is possible only after providing financial guarantees of payment [9].

Social networks have a great influence on consumer behavior in tourism activities. As practice shows, tourists and businessmen often use

smartphones and tablets to find information or share impressions about the place of their stay. Most tourists now travel with modern gadgets filled with a variety of convenient features, they use them to access social networks, post photos on Instagram, publish content on their blogs, on the pages of social networks such as Facebook and Twitter.

Before starting a trip a tourist usually makes a choice of a place to stay, which depends not only on the standard offers posted on the websites of travel companies or Internet portals. The tourist is guided by his or her own cognitive interests, needs and expectations, the advice of acquaintances and friends. A person is not always ready to spend a lot of time to find the necessary information, but is willing to pay more for a quality product, if it is available and the information about it is reliable. Social networks have created an excellent technical and emotional opportunity to facilitate the collection of a variety of data on available travel offers. They allow to build a so-called “fragment of the collective tourist picture of the world” on the basis of the experience presented in the global network, which allows the potential tourist to get the most relevant information about the visiting country, based on the reviews and comments of people who have been there. The use of social networks allows the consumer to gather information “first-hand” and on this basis to make a responsible decision. Gathering information is possible through blogs and forums, multimedia portals, photo and video sharing. Note that an important role in this process is played by such special platforms for sharing impressions and comments as wanderfly.com (helps to make a travel plan based on the analysis of tourist interests and capabilities), tripwolf.com (travel guide to the world) and other accumulated servers of online content about tourist products and services. The intensity of the use of social networks in tourism activities is constantly growing. Given the low cost of communication, wide audience and high speed of information distribution, social networks have become one of the most important marketing tools in the process of promotion and sales of tourist services. Tourists can now post reviews, comments and demonstrate their own vision of a tourist trip (most often not at all similar to advertising information), as well as easily communicate this information to the global community.

As practice shows, online broadcasts on social networks Facebook or Twitter with the publication of photos and videos attract users more. An

important point in this case is regular updating of pages, posting relevant information and maintaining a news resource to capture the interests of the community. Therefore, the management of a tourist enterprise needs to identify a key person who can be an authoritative opinion leader, able to conduct a dialogue with the audience, comment on the news, give interviews and maintain their personal blog. It should be noted that the result of work in social media can be unpredictable for an enterprise due to incompetence or lack of coordination of personnel, which can damage its image. Therefore, the key factor for the successful promotion of tourist products and services in the global network is a clearly developed strategy and tactics of work, professionalism of employees. Unfortunately, most tourist enterprises are not ready now to allocate funds for marketing activities in social media, which is a confirmation of the underestimation of the importance of such work.

In addition to popular social networking sites, you should pay due attention to well-known video hosting sites like YouTube, which allows Internet users to upload, view and discuss videos. Thanks to its simplicity and ease of use, YouTube has become one of the most popular places to post videos. The site features professionally produced movies and clips, video blogs, as well as amateur videos and video blogs. The advantage of this video hosting site is that it can provide TV information at any time. The modern tourist gets acquainted with a country, a city or a hotel via the Internet, and most often via YouTube. The tourist is interested not only in information about the place of future stay, but also the events directly occurring there, the reaction to them by the authors of blogs and readers who make comments on the site. While the official media try to hide unfavorable events for longer, it is impossible to do so in a video hosting site.

For example, during the large-scale forest fires in southern Turkey in the summer of 2021, many tourists took pictures via mobile devices and posted footage of such an environmental disaster on the site, which contributed to the rapid spread of information about it. This video hosting is an attractive resource for tourism businesses as well as for small TV companies and satellite TV channels. Through YouTube are shown various programs about tourism, history, culture, programs about ecology, fauna and flora. So far the video hosting becomes an information center for millions of modern tourists. Therefore, innovations related to the use of YouTube in the organization of tourist activities have a great prospect.

5. Digital technologies and devices

The main digital technologies of tourism activities are the Internet of Things, artificial intelligence, big data, blockchain, monitoring systems, robotics, virtual reality, cloud computing and many others.

The Internet of Things is already an essential element of the travel service. Devices are connected to the Internet, interacting with each other and equipped with sensors, sensors, and technologies for transmitting and receiving information.

For example, with the help of mobile applications customers can regulate the temperature and lighting in the hotel room around the clock, control the TV, book spas, have access to services in the rooms and their cleaning.

Such an approach solves many problems (economical use of energy and material resources, lack of parking spaces, loss of orientation in an unfamiliar area, control over the movement of luggage, etc.), and also reduces to a minimum all kinds of expectations of the tourist during the rest.

Using artificial intelligence technologies, in particular chat-bots, it is possible to book a hotel room, tell the rules of conduct, order food from a restaurant, control the temperature and lighting in the room, call a cab, plan a travel route or walk around the city.

Chat-bots are computer programs, virtual assistants that mimic a live person, answer questions and customer requests using messenger applications. Chatbots are designed for users who want to quickly find the information they need without directly contacting managers by phone.

A tool like big data can help travel companies improve their operations and make faster and smarter decisions. Data is collected from many sources, including email, mobile devices, apps, etc. This data is grouped, processed, stored, and then analyzed, during which companies gain useful information.

Airlines use big data to understand passenger behavior, route choices, overall industry performance, and to increase their revenue opportunities. Hotels and resorts can use big data to provide customer packages and exclusive offers.

Blockchain technologies are already widely used in tourism: collecting and controlling information about the movement of luggage between different airlines and airports; identifying passengers through retinal scans or fingerprints; and arranging payment for services;

Blockchain technologies are responsible for the reliability of orders, reservations, secure payments and other elements of the digital environment.

Work in tourism is another promising area of development. The use of robot-guides in museum tours, robot-guides capable of understanding people, performing the functions they need, are becoming a reality today. Vacuum cleaners-workers are already firmly in use, reducing the need for personnel.

Through the use of artificial intelligence, particularly recognition technology, it is possible to: speed up tourist check-in times at airports; allow visitors to access a hotel room by scanning their retina or fingerprints. Such service provides visitors with additional conveniences, in particular increases the security of stay in the hotel; improve the quality of customer service through personalization of services.

Personalization of service is one of the most important competitive advantages that cannot be achieved without digital technology. To understand a customer's needs and desires, you need to collect and process a huge database related to their previous travel experiences, hotel stays, etc. This will allow to form a certain virtual image of the tourist, to foresee his needs with the help of artificial intelligence systems, to provide remote service with the help of chat-bots. The advantages of servicing with the help of artificial intelligence systems should include the accuracy and speed of providing information to the client. Artificial intelligence allows you to quickly process information and offer different options for solving a problem, for example, by offering several accommodation options with comments personal to the customer. The use of modern digital technology increases the safety and quality of tourist services [3].

For managers of enterprises and organizations in the tourism industry, the use of digital technology allows: increase the investment attractiveness of the tourist enterprise; control labor productivity and efficiency of business processes; quickly identify “weak points” in the management of processes in tourist enterprises; increase the availability of tourist services, quality of service and services; develop tourist industry enterprises through increased integration processes between service organizations and tourist enterprises; accelerate the introduction of energy and resource-saving technologies [9].

In the hotel and restaurant business in conditions of fierce competition the application of digital technologies attracts more and more new visitors.

The development of QR code opened new unlimited opportunities for interaction of companies and consumers on-line. The matrix code is able to hold a huge volume of information by means of text, figures, URLs, calendars, diagrams, images. The speed of QR code recognition is very high, it can be placed on any media, starting from cash register receipts and menus and finishing with different signs. It can be scanned by cell phone or video camera [11].

The restaurants have started to use QR-code to attract the clients. At the entrance to the restaurant they place the advertising poster or the menu with the printed code. Having read the code, the user can get the link and go to the site of the restaurant, look through the menu or get the link to the site, where he can look through the reviews of the users about the restaurant.

Creating an electronic menu that allows the administration to increase the efficiency of communication between customers and employees. It also speeds up the process of updating the menu. For example, customers can independently select a wine by year, price, region, etc. from the house wine list and then choose a dish from the local menu; calculate the caloric value of certain dishes; when choosing dishes, immediately see the final check of the order; while waiting for the order to play games, read the news, etc.

There is a tendency of active introduction of innovative workings out in hotel business: equipment of rooms by conditioners with possibility of adjustment of air stream; electronic locks with keys-perforated cards, in future by mini chips which read the information on an iris of eye or through the special program loaded on guest phone; high-speed intellectual elevators; advanced television systems; wireless output in the Internet; individual alarm system, etc. [12].

Digital technology is actively being introduced in the security of tourists, especially mountain and extreme tourism. Planning tours, providing full information about them, living conditions, climatic features of the country, the system of quick reports on weather changes and emergencies will reduce the risks of tourists and increase the attractiveness of the country for tourists.

6. Virtual technologies

Currently quite popular among the marketing activities of enterprises in the tourism industry are virtual tours, which allow the potential tourist to travel, realistically reflecting the object and service, using modern features and 3D-technology.

Virtual tours are presentations that allow you to see tourist sites before you actually visit them. They can be panoramas of objects of any size (exhibits of museums and art galleries, hotel rooms, streets or city buildings, park alleys, bird's-eye views). Panoramas are connected with each other by simulated long movements inside the object in such a way as to create the illusion of real movement along and inside the object with the possibility of stopping for a circular view in the most interesting places. Virtual tours are often in demand in tourist activities, where they are called "virtual tours. This technology allows you to zoom in or out of any object, examine individual interior details in detail, examine the panorama from afar, look up and down, go back by the sides, move closer to the selected point or away from it, through active zones to move from one panorama to another. You can walk around the house from the inside or look at it from the outside, take a virtual trip to an exotic island without leaving your own apartment. And all this is done in an order and rhythm that is determined by the particular user.

Of course, the use of virtual tours helps to eliminate most of the problems that arise when conducting tours in real time: conducting excursions in the real space of museums, galleries or on the streets of the city requires great professional skill, the ability to control oneself in an unfamiliar environment, to hold the listeners' attention during the performance; the administration of museums or galleries often prohibits unauthorized persons to conduct tours in the halls; weather conditions sometimes do not allow implementing the intended plan and conducting tours on the chosen topic on the city streets; the presence of street traffic in a large metropolis sometimes delays bus tours and prevents quickly familiarizing yourself with the various objects.

Stressing all the positive aspects of the virtual excursion, it is necessary to note and one minus – even so close but virtual communication with the values of culture is a surrogate for the real perception of art. Therefore, excursion work with display objects on the Internet should be carried out either as a preparatory to the perception of a work of art in reality, or as a substitute for the perception of a real work of art if it is impossible to see or hear it in the original. The most important task of a virtual tour is to create a desire to come to a museum or an art gallery and see all the exhibits in the original.

Particularly, Google has launched a project Performing Arts, which is a virtual tour of the world-famous theaters with a 360-degree view

that creates the effect of presence. The project Google Cultural Institute allows the lovers of theater and music to virtually visit, among others, the Berlin Philharmonic, Carnegie Hall concert hall in New York, the Royal Shakespeare Company in Britain and others. Performing Arts is a part of the Cultural Institute project, where you can visit online exhibitions, explore museum collections, and make a virtual trip to the theater [13].

The latest digital technologies used in tourism activities are augmented reality systems. These technologies make it possible to significantly increase the amount of information perceived by humans. This expansion of consciousness is achieved by transferring digital information into the real world. The process of augmented reality is formed by the camera of a smartphone, webcam or other device that can process a video signal. A special program supplements the picture with the necessary virtual objects. The main difference between augmented reality technology and its virtual counterpart is the ratio of information received from the real world and processed by the computer. Virtual reality tries to fully absorb the real world, while augmented reality only extends the understanding of the processes occurring in it. People interested in the functions of modern mobile devices have probably heard about Google's technological innovation. We are talking about Google Glass augmented reality glasses, which operate on the basis of the user's verbal and voice commands. These glasses can become one of the first devices that will demonstrate augmented reality technology to a wide range of consumers. We can already name the spheres where glasses have found their niche: medicine, robotics, education and marketing, maintenance and repair, military and aviation navigation, tourist activities (sightseeing and museums), entertainment, etc.

For example, the Abadia Retuerta Le Domaine Hotel, located in the Spanish Abbey. The hotel itself, which was built in the 12th century, is a unique architectural monument. The administration of the institution has bought Google Glass glasses for their use during the interactive tours in and around the hotel. In addition to such tours, the user with this device can get interactive information about the hotel's sports and recreational infrastructure and menus in the local restaurant.

Another example of the use of augmented reality technology in tourist activities can be found in tourist centers, such as Cedar Point amusement and recreation park in Ohio, USA. The organizers developed an augmented reality

application, The Battle, with the help of which tourists can participate in various competitions on the territory of the park and compete with each other by scanning markers. The introduction of this technology made it possible to turn the theme park into a giant video game, due to which the attendance of the park and, accordingly, the income increased significantly [14, p. 220].

The use of augmented reality techniques by botanical gardens will help introduce visitors closer to the world of living nature, show the dynamics of processes and hidden connections, immerse themselves in micro-worlds or go back millions of years.

The Jurassic Garden project in Australia serves an educational function, highlighting plants that were once a source of food or an environment for ancient animals. By downloading the program of the same name, users can take photos of huge virtual dinosaurs created by digital technology. This augmented reality project is now available to visitors of 3 botanical gardens: the Royal Botanical Gardens of Sydney, the Australian Botanical Gardens of Mount Annan and the Blue Mountains Botanical Gardens of Mount Tom.

Augmented reality will provide information not only at certain points, but throughout the entire tour route. For example, you will be able to learn what changes occur to plants at different times of the year, see the change in landscapes during different historical periods, and learn about the history of the exhibits. Since the limited space of greenhouses cannot reproduce the vegetation, augmented reality will help to transport the tourist into the fynbos of South Africa, equatorial forests of South America or subtropical forests of Australia.

Another area of application of augmented reality technology is the reproduction and simulation of historical objects.

Today you can still see more or less preserved medieval castles and fortresses, but many ancient structures have only fragments left. A large number of architectural treasures have been lost on the planet, and their restoration is no longer possible. It is very difficult to imagine how they “fit” into the landscape, but with the help of a special device you can see that once in this very place. An example of the practical implementation of such a project is the company “Pilgrim XXI”, the developer of augmented reality devices for the world tourism market. In particular, the company’s specialists have restored the Livonian Order castle in Latvia. Now users with this device can see the walls and brick towers, walk through the courtyard of the citadel accompanied by an audio-musical tour [14, p. 221].

Tourist sphere has a rich functionality and one of the leading functions after recreational, of course, is educational. If we analyze classical literary and historical sources, we learn that since the 17th century educational voyages – “grand tours” were popular among the rich aristocratic youth. Through digitalization, such a function can be optimized. You don’t have to go to Italy to hear the singers of La Scala Opera.

The experience of holding cultural and educational events on the example of the Potocki Palace in Tulchin is interesting. OPERAFEST started in 2018 and has become a real tourist magnet in the tourist attraction of the region. There is a positive result: for many years the palace was falling apart and now, after attracting the attention of the general public, investors, restoration works will be carried out under the auspices of the Presidential Foundation.

Providing an educational function can be expressed in the creation of digital thematic portals for teachers and with the participation of teachers. After all, many tourist sites are connected with the history of Ukraine and can become a subject illustration of the textbook material. Especially popular are theatrical reconstructions of real battles, such as, say, episodes of Khotyn war, which are held on the territory of Kamyanets-Podilsky fortress by different clubs of historical reconstruction. Even the history of small towns of Voronovitsy and Nemiroff are inscribed in the world and national history, and thanks to the existence of thematic digital portals can be useful when studying the history of Ukraine. Also due to digital technology can happen popularization of such an important area as local history.

Broad involvement of digital technologies will help to establish links cultural and artistic sphere and tourist attractiveness of territories, the definition of areas of common interest. Legislative documents of municipalities and united territorial communities, development strategies are used to pass through the priorities of tourism and culture development. Relevant regional programs are updated on the basis of the most attractive in terms of tourism sites of historical, cultural and natural value. Powerful tourist and hotel complexes are being built, the existence of which is impossible without a wide toolkit of Internet and digital services.

The issue of total digitalization, the transfer of tourist sites in virtual space is in polemical mode. According to research by the World Tourism Organization, about 40% of tourists determine the purpose of their trip on the basis of the cultural offer. Intangible factors such as the “atmosphere of

a place”, its connection to famous people, ideas or events – in other words, the culture, history and traditions of a place – are becoming increasingly important to the tourist. In practice, this manifests itself, in particular, in the lobbying by municipalities of major cultural programs and projects that create the “atmosphere of place,” preserving the mental map of the region and the national identity, which is especially valuable in the context of globalization.

7. Conclusions

The introduction of digital technology in the tourism business faces a number of problems, which include: high prices for tourist services, underdeveloped communications and transportation network that does not meet the requirements of modern tourists, insufficient use of digital technologies in security and insurance in the organization of tourism activities, the weak development of rural tourism and their digitalization, lack of highly qualified specialists in information support of tourism business.

To overcome the existing problems of the tourism industry of Ukraine needs a serious enough effort to achieve compliance with modern world standards. It is necessary to attract a sufficient amount of financial investment, which Ukraine still does not have in sufficient quantities. Crowdfunding as a modern instrument for financing innovative projects is a way out of the situation.

Crowdfunding is a collective cooperation of people who voluntarily pool their money or other resources together over the Internet to help other people or organizations. In Ukraine there are several platforms on which it is possible to collect money for realization of various projects, in particular, tourist projects: Ukrainian Charity Exchange, Community, Indiegogo, GlobalGiving, Causes, Crowdrise, Firstgiving, Kickstarten, HelpStarter, Na-Starte [15].

The use of digital technology in the tourism industry is a requirement of the times, allowing not only to improve the quality of services, but also to use all available resources rationally. The impact of digital technology on tourism is felt at different stages of activity: marketing, management, service delivery, etc.

Today, tourist and recreational complexes are becoming increasingly important, creating a tourist attraction of the region and satisfying the most demanding requirements of the user of tourist services. Along with the main tourist object there are hotel, restaurant and entertainment complexes, toy stores, souvenir stores, thematic master classes. When

creating the “atmosphere” of the object and providing quality services plays a big role technologically equipped industry. Tourism has always been a technologically dependent industry and has responded organically to the development of digital technology. All information and communication aspects of tourism are transformed into virtual space. Such shifts will significantly improve the promotion and economic component of the tourism industry, of course, if there are programs to support it.

In the future, digitalization of the tourism industry will be accompanied by a further process of displacement of traditional companies with offline offices, the development of designing tours according to the parameters individually set by each specific client, and therefore, the advantages in competition will be those tourist enterprises which can implement the process of customization in the best way. Providing tourist services to consumers, turning them into loyal customers, ensuring their survival in the long term on the basis of consistently high profit and profitability.

References:

1. Kozhukhivs'ka, R. B. (2015). Napryamy zastosuvannya informatsiynykh tekhnolohiy u komunikatsiynykh stratehiyakh ukrayins'kykh turystychnykh pidpryyemstv i pidpryyemstv industriyi hostynnosti [Directions of application of information technologies in communication strategies of Ukrainian tourist enterprises and enterprises of the hospitality industry]. *Biznes Inform – Business Inform*, 10, 119–125. (in Ukrainian)
2. Zhezhnych, P. I., & Soprunyuk, O. O. (2014). Osoblyvosti formuvannya informatsiynoho zabezpechennya turystychnoyi diyal'nosti [Features of formation of information support of tourist activity]. *Visnyk Natsional'noho universytetu «L'vivs'ka politekhnika»*. Seriya: *Informatsiyni systemy ta merezhi – Bulletin of the National University «Lviv Polytechnic»*. Series: *Information systems and networks*, 783, 336–343. (in Ukrainian)
3. Marusey, T. V. (2020). Didzhitalizatsiya turystychnoho sektoru yak instrument rozvytku v suchasnykh umovakh [Digitalization of the tourism sector as a tool for development in modern conditions]. *Efektivna ekonomika – Efficient economy*, 8. Retrieved from: <http://www.economy.nayka.com.ua/?op=1&z=8116> (in Ukrainian)
4. Mel'nychenko, S. V. (2008). *Informatsiyni tekhnolohiyi v turyzmi: teoriya, metodolohiya, praktyka* [Information technologies in tourism: theory, methodology, practice]. Kyiv: Kyiv. nats. torh.-ekon. un-t. (in Ukrainian)
5. Lytovchenko, I. L. (2011). *Internet-marketynh: navchal'nyy posibnyk* [Internet marketing: a textbook]. Kyiv: Tsentр uchbovoyi literatury. (in Ukrainian)
6. Skopen', M. M. (2005). *Kompyuterni informatsiyni tekhnolohiyi v turyzmi* [Computer information technologies in tourism]. Kyiv: Kondor. (in Ukrainian)

7. Kozhukhivs'ka, R. B. (2012). Zastosuvannya internetu yak zasobu informatsiynykh tekhnolohiy u strukturi komunikatsiynoyi modeli turystychnoyi haluzi [The use of the Internet as a means of information technology in the structure of the communication model of the tourism industry]. *Ekonomika ta derzhava – Economy and Power*, 4, 61–63. Retrieved from: http://www.economy.in.ua/pdf/4_2012/20.pdf (in Ukrainian)

8. Ukrayina 2030E – krayina z rozvynutoyu tsyfrovoyu ekonomikoyu [Ukraine 2030E is a country with a developed digital economy]. *Ukrayins'kyi instytut maybutn'oho: veb-sayt*. Retrieved from: <https://strategy.uifuture.org/kraina-z-rozvinutoyu-cifrovoyu-ekonomikoyu.html> (in Ukrainian)

9. Hlyebova, A.O. (2016). Informatsiyno-innovatsiyni tekhnolohiyi v protsesakh turystychnoho obsluhovuvannya [Information and innovative technologies in the processes of tourist services]. *Hlobal'ni ta natsional'ni problemy ekonomiky – Global and national economic problems*, 13, 230–235. Retrieved from: <http://global-national.in.ua/archive/13-2016/48.pdf> (in Ukrainian)

10. Holovnya, O. M., & Stavs'ka, Yu. V. (2020) *Mizhnarodnyy turyzm: navchal'nyy posibnyk* [International tourism: a textbook]. Vinnytsya: TOV «Druk». (in Ukrainian)

11. Zasadna, Kh. O. (2014). QR-koduvannya ta al'ternatyvni tekhnolohiyi [QR-coding and alternative technologies]. *Finansovyy prostir – Financial space*, 3(15), 103–108. Retrieved from: <https://ofp.cibs.ubs.edu.ua/files/1403/14zhoqta.pdf> (in Ukrainian)

12. Stavs'ka, Yu. V. (2018). Osoblyvosti ta zmist innovatsiy u sferi hostynnosti [Features and content of innovations in the field of hospitality]. *Ekonomika, finansy, menedzhment: aktual'ni pytannya nauky i praktyky – Economics, finance, management: current issues of science and practice*, 3, 35–46. (in Ukrainian)

13. Sahirova, A. S. (2019). Potentsial IT-tekhnologiy u stymulyuvanni rynku turystychnykh posluh [The potential of IT technologies in stimulating the market of tourist services]. *Universytet-s'ka nauka – 2019: tezy dop. Mizhnar. naukovo-tekh. konf. (Mariupol', 16-17 travnya 2019 r.): v 4 t. / DVNZ «PDTU» – University Science – 2019: thesis add. International. scientific and technical conf. (Mariupol', May 16-17, 2019): in 4 volumes / SHEI «PDTU»*. (Vols. 4, pp. 103–104). Mariupol'. (in Ukrainian)

14. Kozlovskiy, Ye. V. (2017). «Features of implementation of the modern multimedia technologies in tourism», *Novi media v suchasnomu suspil'stvi: kul'turolohichnyj vymir: monografii* [New media in modern society: cultural dimension: monograph]. Kyiv. (in Ukrainian)

15. Holovnya, O. M. (2019). Innovatsiyni tekhnolohiyi finansuvannya sotsial'noho rozvytku natsional'noyi ekonomiky [Innovative technologies for financing the social development of the national economy]. *Naukovyy visnyk Ivano-Frankivs'koho natsional'noho tekhnichnoho universytetu nafty i hazu. Seriya: Ekonomika ta upravlinnya v naftoviy i hazoviy promyslovosti – Scientific Bulletin of Ivano-Frankivsk National Technical University of Oil and Gas. Series: Economics and Management in the Oil and Gas Industry*, 2, 93–102. Retrieved from: http://nbuv.gov.ua/UJRN/nvifnunge_2019_2_10 (in Ukrainian)

INVESTMENT ATTRACTIVENESS OF THE ENTERPRISE: CONTENT, FACTORS OF INFLUENCE AND DIRECTIONS OF IMPROVEMENT

Oksana Ruda¹

DOI: <https://doi.org/10.30525/978-9934-26-193-0-8>

Abstract. At the current stage of economic development, which is characterized by high speed of change, instability and uncertainty, to ensure a continuous process of economic development of enterprises encourages all businesses to strengthen their position in the market environment. They need to accelerate investment processes to become more competitive. Investment attractiveness plays an important role in this, as it is a driving force to increase the company's capabilities.

The presence of a high level of investment attractiveness has a positive effect on the market value of enterprises and is a guarantee of obtaining the necessary amount of investment resources for further economic development. However, enterprises in a state of financial and economic crisis are often characterized by a low degree of their investment attractiveness.

The high level of investment attractiveness provides a stable inflow of investments into the country, additional revenues to the state budget, a better social environment in the country.

The investment attractiveness of the company plays one of the main roles in the development of the company and increase its competitiveness in the market. In order for an investor to decide which company to invest in, he needs information about the strengths and weaknesses of the company, prospects for its further development and the ability to ensure the highest efficiency of investment.

Investment attractiveness is an integral indicator that characterizes the feasibility of investing in a particular object from the standpoint of a particular investor. Existing methods of assessing investment attractiveness involve the calculation of an integrated indicator based on the coefficients of

¹ Candidate of Economic Sciences, Associate Professor,
Department of Finance, Banking and Insurance,
Vinnytsia National Agrarian University, Ukraine

property status, liquidity and solvency, financial stability, business activity, taking into account their relative importance and the level of compliance with regulatory values and dynamics. In modern conditions, research in this area does not lose its relevance, as the correct choice of investment object is one of the prerequisites for obtaining the desired effect in the future.

That is why the main objectives of assessing investment attractiveness are: determining the current state of the enterprise and prospects for its development; development of measures to increase investment attractiveness; attracting investments in the amounts corresponding to investment attractiveness and obtaining a comprehensive positive effect from the development of borrowed capital.

The main requirement for any method of determining the level of investment attractiveness is the ability to interpret the information obtained and make effective and appropriate management decisions based on certain indicators, both by the investor to invest and by the recipient company to increase its investment rating.

Thus, taking into account the management of investment attractiveness of internal and external factors will allow the company to effectively manage them to increase its investment attractiveness, and the investor – to assess investment attractiveness in order to carry out investment activities.

The article reveals the concept of investment attractiveness of the enterprise. Factors influencing the investment attractiveness of the enterprise are highlighted. A number of problems have been identified that cause a low level of investment attractiveness of enterprises. The main methods of assessing investment attractiveness at the enterprise level are considered.

1. Introduction

In modern business conditions, in the presence of a shortage of investment resources, the entity that has its own funds or the opportunity to attract them in any way, is always able to choose the region, industry and entity where the investment project will be implemented. The main task of this choice is to assess the investment attractiveness of the investment object. Given the shortage of internal and external investment resources, the lack of state support on this issue, the investment attractiveness of economic entities is very important. The assessment of the investment attractiveness of the business entity should provide answers to the question of where,

when and how many resources can be sent by the investor in the process of investment.

Every company is interested in increasing its own capital, the most attractive is attracting external sources, and investors, in turn, in making a profit and increasing it, and to avoid losses, they evaluate the effectiveness of investing in an existing project.

The aim is to analyze the investment attractiveness of the enterprise and develop proposals to increase its investment attractiveness.

The methodological basis of the study are objective laws and fundamental provisions of economic theory, theory of investment management, scientific works of domestic and foreign scientists. Methods of systematic approach in the process of determining the essence of investment attractiveness and methods of analyzing investment attractiveness management, statistical methods – to study the impact of factors on changing the level of investment attractiveness, comparative analysis of economic indicators, tabular method – to systematize company data, graphical method.

The scientific novelty of the obtained results is to deepen the theoretical and methodological foundations of the study of factors influencing the investment attractiveness of enterprises and the development of scientific and practical recommendations for attracting investment in enterprises in the context of global challenges.

2. Investment attractiveness of the enterprise and factors of influence

The concept of investment attractiveness of the enterprise was first formulated and enshrined in order № 22 of 23.02.1998 by the Agency for Prevention of Bankruptcy of Enterprises and Organizations in the “Methodology of integrated assessment of investment attractiveness of enterprises and organizations” [15].

According to it, the investment attractiveness of the enterprise is the level of satisfaction of financial, production, organizational and other requirements or interests of the investor in relation to a particular enterprise, which can be determined or evaluated by relevant indicators, including integrated assessment.

Complexity and versatility investment the attractiveness of the enterprise is caused by the diversity of its types, which can be grouped by a number

of classifications signs. In particular, issued appropriate supplement you are existing in the scientific literature methods of grouping species investment attractiveness enterprises such as:

1) by object attachments investment by division investment attractiveness for current and future Well. At the same time, the current investment attractiveness of the firm will characterize peace expediency acquisition certain shares the share capital available to the enterprise. As for the long-term attractiveness of the company, then it characterizes the feasibility of investing in projects that involve some changes in internal environment enterprises. In particular, to such projects it is possible one sti and measures with anti-crisis management on enterprise, what in need attachments investment in their implemented no;

2) at the time of formation by dividing the investment attractiveness enterprises on existing (existing on now) and the future (tu, which expected according to with about purulent estimates by certain interval time);

3) by way representation results evaluation by division investment attractiveness enterprises for quality (which is described by qualitative characteristics), rating (which served in kind of certain places in the rating of investment attractiveness by group to under investigation subjects management) and quantitative (which characterized by a certain numerical value or lower numerical values);

4) by subject evaluation by division invest the attractiveness of the enterprise is assessed by the owners and employees of the enterprise as potential investors or from the position of potential investors, assessed by external potential investors, assessed independent researchers from the standpoint of potential investors;

5) by quantity investors – appraisers by on- case of investment attractiveness of the enterprise on individual (as a result of estimation by certain potential investor) and average (as result averaging estimates of this attractiveness provided by several potential them investors);

6) by the method of calculation by dividing the investment valuable attractiveness enterprises on absolute, when assessing which there is no comparison of the level of this attractiveness with the level of investment attractiveness some other enterprise, and relative, in the assessment bath which is a comparison of the level of this attraction with the level of investment attractiveness of another enterprises;

7) by immutability (change) in time of its level by division of investment attractiveness of the enterprise into one hundred sick (the level of which remains unchanged or is changing insignificant for certain interval time) and variable (the level of which changes significantly during certain interval time);

8) by the time of evaluation by dividing the investment attractiveness of the enterprise by the moment (which is set on certain moment time) and averaged interval (which is determined by averaging the instantaneous values for certain interval time);

9) in response to the possible influence of a certain factor by division investment attractiveness enterprises are neutral to this factor (ie one that does not respond to the influence of a certain factor) and neutral to the factor (ie one that reacts to the influence of a certain foot factor in accordance changing your level);

10) in the presence (or absence) of potential for turn by division investment attractiveness enterprises for one that is characterized by a certain potential its development, and such in which this potential is absent.

Trace note what concept “development investment attractiveness enterprises” needs separate interpretation, because it plays significant role in research patterns formation and evaluation this one attractiveness. In general development investment attractiveness enterprises trace identify from improvement in time its certain characteristics (characteristics) due implementation potential such development. Such characteristics is enough many, but most significant trace recognize the level of investment attractiveness of the subject of state donation. Regarding the assessment of this level in relation to current investment attractiveness of the enterprise, then with this purpose trace perform such sequence actions:

1) collection input information necessary for evaluation current investment attractiveness enterprises;

2) definition forecast average annual quantities profit enterprises to pay interest by loan – we and taxes with profit;

3) justification annual rates capitalization among annual quantities profit enterprises to be paid interest by loans and taxes with profit;

4) implementation capitalization average annual quantities profit enterprises to be paid interest for poses – kami and taxes with profit;

5) subtraction from capitalized average annual quantities profit enterprises to be paid interest for loans and income taxes volume loan capital enterprises.

The investment attractiveness of an entity is influenced by groups of factors of direct and indirect influence.

Factors of direct influence or internal:

1) Analyzing the investment attractiveness of the object of investment by technical factor, compare existing and necessary for its development fixed assets by their composition, structure, including age, their capacity, productivity, level and time of actual use.

2) Investment attractiveness by labor factor involves the analysis of qualifications, demographic composition of employees. In case of non-compliance of the staff with progressive samples, the possibilities of its retraining, financial and time costs necessary for the labor collective to achieve the appropriate level of qualification parameters are assessed.

3) The impact of organizational factors on investment attractiveness is considered through the assessment of the effectiveness of the existing set of measures to combine living labor with the material elements of production.

4) Determining the resource-raw material factor, assess the availability of the necessary materials, in the right types and quantities, raw materials and components.

5) Assessment of profitability, profitability, profitability, liquidity, business activity, financial stability of the business entity, taking into account the payback period of investments and their profitability is aimed at assessing financial and analytical factors.

Factors of indirect influence or external:

1) The influence of geographical factors is analyzed through the parameters of the location of the enterprise, the level of employment and unemployment in the region, the availability of potential labor force depending on its qualification level and specialization.

2) Examining the economic activity of the business entity in terms of its compliance with existing regulations on ecology, environmental protection, sanitary and hygienic standards.

3) The set of factors influencing the monetary sphere, the banking system and other components of the infrastructure of the economy, the mechanisms of export-import operations, inflation, fluctuations in the national currency.

4) The stability of the political system, the presence or absence of conflicts between political opponents, the frequency of changes in government, the number of political scandals, the degree of trust in government, etc. fills the module of political factors in the model of factor analysis.

5) Legislative factors are characterized by the influence of the Constitution, general and special branches of law that protect property rights and investors, provide for direct action and mechanisms for collecting taxes.

Investment attractiveness of the enterprise – the level of satisfaction of financial, production, organizational and other requirements or interests of the investor in relation to a particular enterprise, which can be determined or assessed by the values of relevant indicators, including integrated assessment.

Examining the investment attractiveness of business entities, in our opinion, it is advisable to consider it from the standpoint of ensuring the possibility of realizing the investment potential of the enterprise. Investment attractiveness and investment potential are peculiar forms of interaction of investment interest and investment need.

Given that investment needs and investment interest are in contradiction (the desire to obtain significant income with a minimum of investment), it is the interaction between investment attractiveness and investment potential reveals the internal mechanism of investment activity as a driving force of production. At the same time, investment attractiveness is a general characteristic of the advantages and disadvantages of investing in certain areas and objects from the standpoint of a particular investor.

In today's world, foreign investment is one of the main factors in increasing the competitiveness of any national economy. Stabilization of the enterprise with sustainable development of production is of key importance for the economy as a whole, and therefore, increasing investment is one of the incentives to ensure the prosperity of the state as a whole.

Investments considered the main prerequisite public development. But on the way process investing costs a lot obstacles and problems that do not allow do him efficient and orderly. Therefore, one of priorities software sustainable development and improvement competitive market positions environment enterprises are revitalizing investment processes. At the same time investment attractiveness plays a key role element since her level in dynamics determines opportunities enterprises reply I understand potential investors.

Investments classified according to the following characteristics: object investing; degree of control; form of ownership; size; sources investments; the purpose of investment; geopolitical orientation; period investing; regional sign.

The source investment can be both internal, and external resources (foreign investment). The latter help solution problems insufficiency own money and resources, with them effective use country can not only compensate lack internal investment resources, but also to increase competitiveness their own enterprises and national economy as a whole.

In the market conditions exactly competitiveness is complex generalizing criterion success in the economy, which most optimally meets interests investor and purpose him activities. Competitiveness itself enterprises covers a wide range of economic and legal and other characteristics that determine position enterprises at the branch, regional or international markets. This complex includes factors that in general form economic conditions production and sales products. And one of determinants factors competitiveness enterprises are creation attractive investment climate, what will promote more active involvement foreign investment in activities Ukrainian enterprises .

Given the lack of investment resources, an entity that has its own funds or attracts them is always faced with the choice of region, industry or enterprise where the investment project will be implemented. The basis of this choice is to assess the investment attractiveness of the investee. Given the limited internal and external investment resources, the lack of government support on this issue, the investment attractiveness of businesses is very important. The assessment of investment attractiveness should answer the question of where, when and how many resources an investor can invest in the investment process.

In accordance with the current legislation of Ukraine, the assessment of the investment attractiveness of the enterprise involves the analysis of the financial and economic situation according to the approved method of integrated assessment. According to it, the assessment of the investment attractiveness of the business entity is carried out comprehensively, using the main, ie generalizing, indicators of assessing the financial condition of any enterprise, according to the following groups of relations: property status; financial stability; liquidity; profitability; business and market activities [17].

Another group of methods and approaches, based not on the assessment of financial ratios, but on the assessment of cash flows. This position is explained by the fact that cash flows are the basis for the formation of corporate profits, and therefore is a very important component of assessing investment attractiveness.

The following financial indicators are also taken into account when assessing investment attractiveness: availability of resources, profitability of products, number of staff, level of capacity utilization, depreciation of fixed assets, availability of fixed and production assets, etc.

Non-financial indicators reflect the essence of processes, the state of resources, the intensity of their use.

Classify non-financial indicators by function or group of processes of the enterprise, which is analyzed with their help:

- Production (output of finished products; percentage of marriage; time spent per unit of production; number and downtime; time for readjustment; planned analysis of resource costs (electricity, raw materials, water, man-hours); number of complaints);

- Delivery (indicators of timeliness and completeness of fulfillment of orders, turnover of stocks in days, quality of delivered material and technical resources and, accordingly, the number of returns and complaints to suppliers);

- Sales (number and dynamics of buyers, positions in the check, additional sales, resale, number of sales per seller, per square meter of retail space, per running meter of the shelf, etc.);

- Logistics (percentage of transport load, the degree of customer satisfaction, delivery time, number of delays, damage to goods during delivery);

- Promotion (market share, number of calls / conversions / placements, conversion of impressions into clicks, number of links and repost of the video on social networks, brand awareness, consumer loyalty index).

It is necessary to allocate also the indicators characterizing a condition and structure of resources:

- Equipment (its condition is analyzed using non-financial indicators such as capacity and load percentage, variability, percentage of serviceable equipment, share of own equipment / transport, energy consumption, oil, fuel per unit of equipment, number of repairs per period, wear rate);

– Staff (for the analysis of this indicator take data on the number of employees; productivity; the results of the annual certification of employees, average age; etc.);

– Raw materials (balances in the warehouse in terms of nomenclature, consumption rates of raw materials for finished products and actual costs, waste rate, etc.

Assessing the investment attractiveness of the enterprise is usually crucial factor for a potential investor when making a decision. The company itself usually conducts an assessment of investment attractiveness management in order to develop measures to address shortcomings in its activities and measures to increase its own investment attractiveness. Before assessing the investment attractiveness of the enterprise, it is necessary to determine the needs of the investor, ie a list of data that may be relevant to him. Most methods of analysis are built in such a way that the analyzed system of indicators can be changed and supplemented to take into account the wishes of the investor.

Oly Pilipenko emphasizes that all methods in Ukrainian and world practice can be classified in relation to the source of source information [17]:

- methods based on expert reactions;
- methods based on statistical information of the enterprise;
- combined methods, including expert-statistical calculations.

Within another approach to the division of methods for assessing the management of investment attractiveness of the enterprise can be identified free-form methods, ie those that may vary depending on the goals of the enterprise or investor; as well as legalized methods – in Ukraine it may be the Order of the Agency for Prevention of Bankruptcy of Enterprises and Organizations “On approval of the Methodology of integrated assessment of investment attractiveness of enterprises and organizations” [15]. The described method is quite voluminous and complex, as it forms an integrated assessment based on more than 40 financial indicators. In assessing the management of investment attractiveness of the enterprise, you can use general scientific approaches: profitable, costly and market. The first approach analyzes the indicators of capitalization, market value, profitability of the investment project and so on. The cost approach is based on the assessment of the company’s assets and their liquidity. The latter approach – market or comparative takes into account industry ratios, the

effectiveness of previous investment agreements, comparison of competitive advantages, etc. [17].

Existing approaches can also be divided according to what factors they take into account in the assessment. Thus, there is an approach according to which investment attractiveness is formed under the influence of only financial factors, and an approach that takes into account the influence of all internal factors (including financial) and external factors of investment attractiveness.

The investment attractiveness of the object of investment is formed under the influence of certain factors and risks of internal and external nature, which are such driving forces that provide benefits for the company among competitors for investment resources. At the same time, the investment activity of the enterprise is influenced by both quantitative and qualitative factors related to the financial condition, market environment and corporate governance [4; 6].

The concept of “investment attractiveness” applies not only to one company, but also to individual regions and the country as a whole. The level of influence from institutional, economic and social factors is manifested differently at different levels of its implementation, but ultimately individual businesses are directly proportional to different levels of the economy, so the stable development of Ukraine affects the efficiency of the enterprise and the investment climate directly affects the investment attractiveness of individual enterprises.

Investment attractiveness of the enterprise is its integral characteristic as an object of future investment from the point of view of development prospects (dynamics of sales volumes, product competitiveness), efficiency of use of resources and assets, their liquidity, solvency, financial stability, and value of a number of informal indicators [2].

There are many classifications of these factors, as well as opinions about what factors affect investment attractiveness. Numerous scientific papers do not yet reflect a clear and unique answer to these questions.

Consider the most common classification. According to it, all factors can be grouped into two groups: factors of indirect influence and factors of direct influence of the enterprise on investment attractiveness.

The first group of factors includes those that are not affected by an individual enterprise, ie, they can be influenced only at the state level (external factors).

Chapter «Economic sciences»

The second group includes factors that the company can influence and change their performance, characteristics, etc. (internal).

The list of these factors that to varying degrees affect the investment attractiveness of enterprises is given in table 1.

Table 1

Factors influencing investment attractiveness

External factors	Internal factors
1. Industry affiliation	1. Production program
2. Geographical location	2. Marketing activities
3. Availability and availability of natural resources	3. Management accounting and controlling
4. Environmental situation	4. Corporate governance
5. Culture and education of the population	5. Human resources
6. Economic stability	6. Legal activity
7. Socio-political stability	7. Production technologies
8. Regulatory framework	8. Development strategy
9. Information field	9. Competitiveness
10. Benefits for investors	10. Uniqueness of the object
11. Developed infrastructure	11. Duration of the investment program
12. Economic freedom of enterprises	12. Rating of the enterprise in the industry
13. Situation on the world market	13. Payment discipline
14. State control bodies in the field of investment	14. Condition of property and financial resources
15. Inflation rate	15. Costs
16. Possibility of export	16. Capital structure
17. The level of income of the population	
18. Competition in the industry	

Source: [5]

For the company are more important internal factors or factors of direct influence, because it is thanks to them that it is able to independently influence its investment attractiveness.

In turn, among the internal factors, the largest share is occupied by such factors as: human resources, duration of the investment program, the state of property and financial resources, the amount of costs.

It is believed that the investor when choosing an investment object pays most attention to the condition of property, financial condition, financial costs, which is determined by the degree of depreciation of fixed assets, their ability to produce products at a high level, liquidity, solvency, financial stability, indicators of business activity, the state of non-current and current assets, their renewal and disposal.

The amount of costs of the enterprise includes all costs of the enterprise associated with its operating activities [4].

Factors at the enterprise level, industry and regional factors significantly affect the investment attractiveness of enterprises.

Of course, factors at the country level are no less influential, and they are of interest and are used to assess investment attractiveness when a foreign investor appears. In case of attractiveness for domestic investors, they will be interested in the situation at the micro level and in where the company is located. Thus, we can conclude that the factors of the enterprise level and industry level are the basis for scientific discussions.

On the basis of factors that affect the investment attractiveness of enterprises to varying degrees, it is possible to determine the factors of investment attractiveness of the enterprise and determine the indicators that shape these factors (Figure 1).

Enterprises need to be able to analyze external factors and risks, identify the main reasons for their formation in order to improve the level of investment attractiveness. At the same time, investor motivation is also influenced by various factors – political, economic, production, competitive, marketing, environmental and other factors. At the same time, each investor chooses the most important factors and evaluates the selected company depending on their goals, on the basis of which further decides on the feasibility of investing investment resources in the investment object.

Having identified the factors of investment attractiveness at the enterprise level, it is necessary to provide a generalized structure of factors influencing the assessment of investment attractiveness of the enterprise in the context of regional development – regional and sectoral factors (Figure 2).

Assessment of investment attractiveness can be considered as one of the main tasks in the field of investment activities of the enterprise, as investment decisions are always associated with risk.

Chapter «Economic sciences»

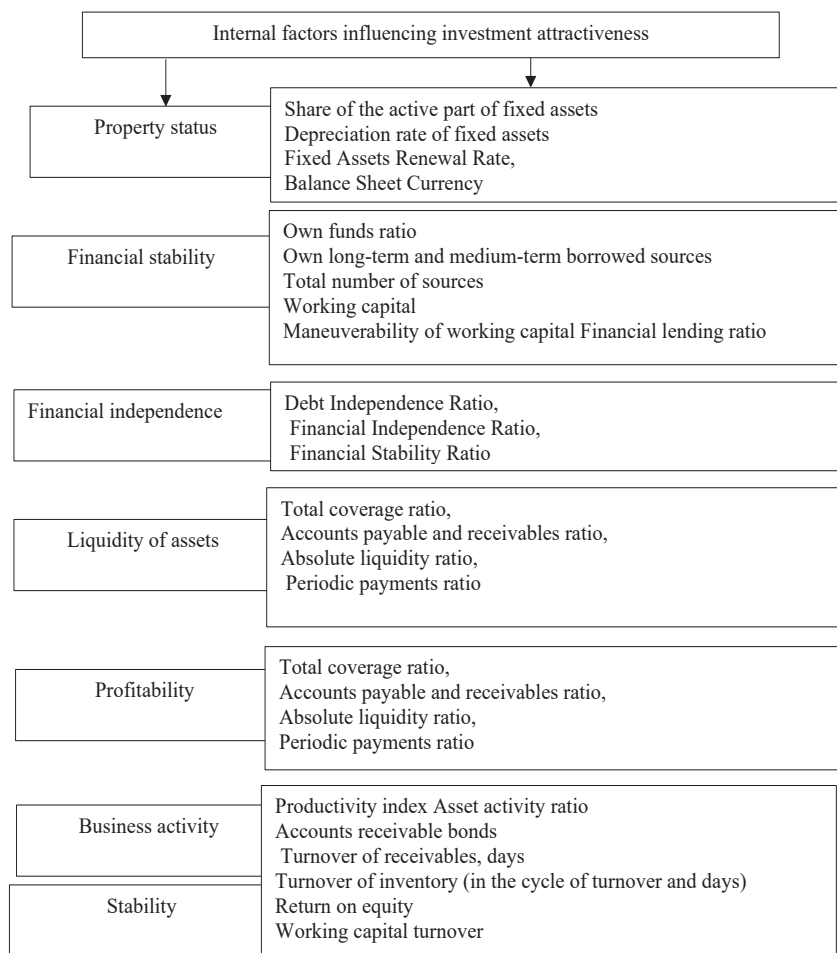

Figure 1. Factors affecting the investment attractiveness of the enterprise

Source: formed by the author on the basis of [3]

The more favorable the investment attractiveness, the less risk, and vice versa. In addition to the risks that arise when investing, the risks inherent in a particular activity are of great importance.

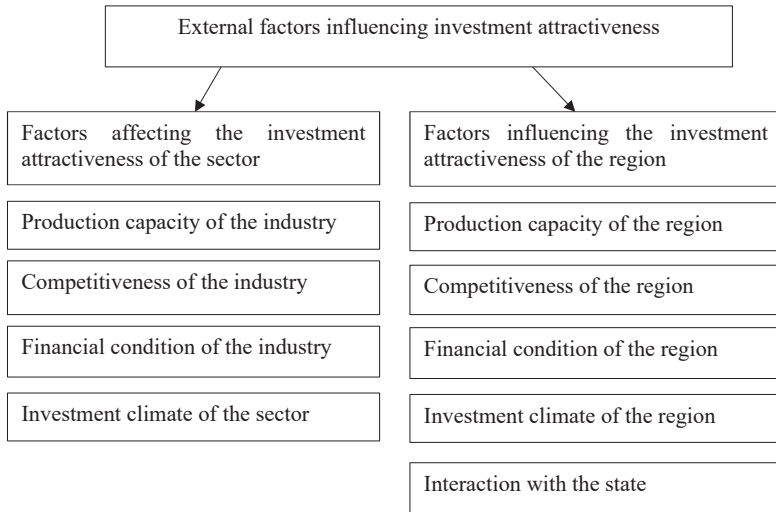

Figure 2. Factors affecting the investment attractiveness of the region and the sector

Source: generalized by the author based on [6]

There are separate groups of risks for each industry, in addition to the generally accepted ones, because the number of risks is quite diverse, and they are inherent in each industry.

Also, the company may suffer from a number of quality factors, which leads to loss of profit by the investor.

These factors may be due to factors such as:

- unqualified management of the enterprise;
- inefficient asset structure;
- incorrect assessment of the financial and economic condition of partners;
- unstable financial position of the enterprise;
- incompetence of the company’s management, etc. [7].

In the table 2 presents statistics on the inflow of foreign direct investment by industry in Ukraine in 2019. by country in terms of activities. The analysis showed that in 2019, 32,291.9 million US dollars were invested in Ukraine’s economy.

Among the countries that have invested the most in the domestic economy, the leader is Cyprus, the volume of investment from which in 2019. amounted to 8,879.5 million US dollars, or 27.5% of total foreign direct investment, the Netherlands – 7,060.9 million US dollars (%), the United Kingdom – 1,955.9 million US dollars (%), Germany – 1,668.2 million US dollars (%) [12].

According to the analysis, the main priority economic activities for foreign investors are trade, food production, information and telecommunications, financial and insurance activities, and metallurgy.

Thus, the priority is determined by the amount of investment in each investment object. Investment attractiveness can be the basis for the priority of investor decision-making for capital investment. Investment attractiveness is assessed separately at the state, industry, regional and business levels, each of which has its own assessment factors.

Table 2

**Volumes of foreign direct investment in Ukraine
in terms of economic activities as of 2019**

Activities	Cyprus		Netherlands		United Kingdom		Germany	
	million dollars USA	in% to the end	million dollars USA	in% to the end	million dollars USA	in% to the end	million dollars USA	in% to the end
Food production	584.8	6.6	725.9	10.3	454.1	23.2	10.1	0.6
Trade	937.6	10.6	1007.9	14.3	258.4	13.2	208.7	12.5
Financial and insurance activities	918.9	10.6	294.2	4.2	256.7	13.1	121.8	7.3
Information and telecommunications	244.4	2.8	1783.9	25.3	25.9	1.3	2.9	0.2
Others	5649.6	63.6	3036.6	42.9	1.3	48.8	749.8	44.9
Total	8879.5	100	7060.9	100	1955.9	100	1668.2	100

Source: summarized by the author based on [12]

Investment attractiveness as a complex indicator is influenced by many factors of direct and indirect action.

The considered theoretical and methodical bases of investment attractiveness and factors of influence on it allow to estimate scientific substantiation and significance of the studied questions of investment attractiveness.

The object may be attractive for investment at the macro level, but not a priority, because at the macro level there is insufficient economic and political stability, there are economic risks [8].

Therefore, each specific investment object must be considered and analyzed at a certain level due to the influence of certain objective and subjective characteristics, because the priority of the investment object is based on its attractiveness to the investment entity.

Thus, the degree of investment attractiveness is a determining condition for active investment activity, and hence the effective socio-economic development of the economy as a whole

3. Assessment of investment attractiveness of the enterprise

At the present stage of development of investment theory, various approaches have been developed and applied to determine the investment attractiveness of the enterprise in accordance with a certain, pre-established, purpose of investment.

The basis for determining the investment attractiveness of economic entities is the method of rating assessment is shown in table 2. This means that two links of indicators are involved, which are used to consider investment attractiveness when compiling a rating. Evaluation according to the rating methodology takes place in two stages [2].

The first stage is determined by the analysis of restrictions imposed by investors in order to select companies and form a list of candidates who meet the above requirements and compete for funding for their own investment program.

The second stage involves the rating of the enterprise from the selected list by way of listing enterprises in order to reduce their investment attractiveness.

The analysis of restrictions is based on the calculation of compliance or non-compliance with the requirements of investors: if the company meets these restrictions, it will be included in the list, if there is non-compliance with the parameters – the company is excluded from further consideration.

Rating assessment is based on the choice of a structural indicator, which is calculated by adding weighted representative coefficients that reflect various aspects of the stability of the financial condition of the enterprise and the efficiency of its activities.

Thus, when compiling the rating, two groups of financial indicators that characterize investment attractiveness are analyzed.

The first of them combines five indicators that reflect the efficiency of enterprises, ie the possibility of making a profit.

The second group includes five indicators that determine the solvency of enterprises, ie provide an estimate of the probability of return on investment [4].

The customer of the investment attractiveness assessment can be both the company itself and a potential investor.

The assessment of the company's investment attractiveness is based on the algorithm for calculating financial indicators (coefficients) proposed by the Agency for Prevention of Bankruptcy of Enterprises and Organizations, which includes the following stages:

- assessment of the property status of the company and the dynamics of its change;

- liquidity analysis;

- analysis of business activity;

- financial stability analysis;

- profitability analysis.

Incoming and outgoing investment cash flows are the main factors in creating the value of enterprises and reflect the effectiveness of investment management. A well-known indicator for estimating investment cash flows is the market value of all invested capital of the entity. The formalized type of calculation of the market value of invested capital (RVIC) is as follows:

$$RVIC = PE + A + \Delta WOC + \Delta NA + \Delta DZ + B$$

where PE – net profit;

A – depreciation deductions;

ΔWOC – changes in working capital;

ΔON – changes in non-current assets;

ΔDR – changes in long-term liabilities;

B – interest payments on the loan.

We will make calculations to determine the market value (thousand UAH) of PJSC “PlasmaTech” for 2018–2020.

**Score assessment of the parameters
of investment attractiveness of the enterprise**

Indexes	Rating				
	okay	satisfactorily	within permissible value	unsatisfactorily	very unsatisfactory
Profitability of sales, %	> 20	5-20	0-5	-20-0	<-20
Return on assets, %	> 15	5-15	0-5	-10-0	<-10
Return on equity, %	> 45	15-45	0-15	-30-0	<-30
Share of depreciation of fixed assets, %	<20	20-30	30-45	45-60	> 60
Return on current assets, %	> 30	10-30	0-10	-20-0	<-20
Current ratio	> 1.3	1.15-1.3	1-1.15	0.9-1	<0.9
Rapid liquidity ratio	> 1	0.8-1	0.7-0.8	0.5-0.7	<0.5
Absolute liquidity ratio	> 0.3	0.2-0.3	0.15-0.2	0.1-0.15	
Ratio of current assets with own funds, %	> 22	12-22	0-12	-11-0	<-11
Coefficient of autonomy, %	> 50	20-50	10-20	3-10	<3

Source: [4]

$$2018 \ 13 \ 404 + 544 + 319 + 2996 + 14.5 + 0 = 4984.5$$

$$2019 \ 52 \ 447 + 765 + (-7925) + 7790.5 + 698.5 + 0 = 1389$$

$$2020 \ 41 \ 383 + 543 + (-5318) + 11776 + 1377.5 + 0 = 9294.5$$

As we can see from the above calculations, the analyzed indicator is positive and has a positive trend of growth in the base year 2020 (9294.5 thousand UAH). Since the analyzed indicator during the study period is positive PJSC “PlasmaTech” can be considered investment attractive.

To assess the investment attractiveness of PJSC “PlasmaTech”, the rating assessment method was chosen. When compiling the rating, two groups of indicators that characterize investment attractiveness are analyzed.

The primary parameters of this technique are as follows:

- “Good” – 2 points;
- “Satisfactory” – 1 point;
- “Within the allowable value” – 0;
- “Unsatisfactory” – minus 1 point;
- “Very unsatisfactory” – minus 2 points.

Table 4

**Score assessment of the parameters
of investment attractiveness of the enterprise**

Indexes	Rating				
	Okay	satisfactorily	within the allowable value	unsatisfactorily	very unsatisfactory
Profitability of sales	> 20	5-20	0-5	-20	<-20
Return on assets	> 15	5-15	0-5	-10	<-10
Return on equity	> 45	15-45	0-15	-30	<-30
Depreciation rate of fixed assets	<20	20-30	30-45	45-60	> 60
Profitability of current assets	> 30	10-30	0-10	-20	<-20
Current ratio	> 1.3	1.15-1.3	1-1.15	0.9-1	<0.9
Rapid liquidity ratio	> 1	0.8-1	0.7-0.8	0.5-0.7	<0.5
Absolute liquidity ratio	> 0.3	0.2-0.3	0.15-0.2	0.1-0.15	-0.1
Ratio of current assets with own funds	> 22	12-22	0-12	-11	<-11
Coefficient of autonomy	> 50	20-50	10-20	3-10	<3

Estimation of parameters of the indicators included in a rating estimation is shown in table 5. The table provides a quantitative justification for the level of investment attractiveness of PJSC “PlasmaTech”.

As we can see from the analysis of PJSC “PlasmaTech” in Table 5 during the analyzed period can be considered investment attractive (because the score for the base period is 2 points, which corresponds to the level of “good”).

The assessment of the investment attractiveness of the company on the basis of the algorithm for calculating financial indicators (ratios) shows that the overall indicator of investment attractiveness of the company during the analyzed period corresponded to the average level.

The calculated indicator of the market value of all invested capital of the business entity on the basis of the proposed method of V.V. Bocharov is positive and has a positive trend to increase in the base year 2019 (9294.5 thousand UAH). Since the analyzed indicator during the study period is positive PJSC “PlasmaTech” can be considered investment attractive.

Table 5

Score assessment of the parameters of investment attractiveness of PJSC “PlasmaTech” for 2018–2020

Indicator	2018	Score	2019	Score	2020	Score
Profitability of sales	1.34	0	5.25	1	3.64	0
Return on assets	1.69	0	5.61	1	2.33	0
Return on equity	9	0	29.4	1	18.27	1
Depreciation rate of fixed assets	0.23	2	0.24	2	0.23	2
Return on current assets	2.77	0	11.06	1	7.51	0
Current ratio	0.81	1	0.71	0	0.65	-1
Rapid liquidity ratio	0.5	-1	0.44	-1	0.47	-2
Absolute liquidity ratio	0.03	-2	0.02	-2	0.03	-2
Ratio of current assets with own funds	44.49	2	58.74	2	42.24	2
Coefficient of autonomy	18.77	0	19.07	0	19.23	0
Sum of points		0		3		-2

Note. Prepared on the basis of financial statements of PJSC “PlasmaTech”

But in 2020, the method of rating the analysis of investment attractiveness of PJSC “PlasmaTech” shows that the company can be considered unattractive (because the score for the base period is -2 points, which corresponds to the level of “very unsatisfactory”).

4. Stimulation of investment activity of enterprises

Before assessing the investment attractiveness of an individual enterprise, first of all, foreign investors assess the level of investment attractiveness of the national economy.

The main indicators of assessing investment attractiveness at the macro level are: World Bank Group, Standard & Poors Rating Services, Moody's

Investors Service. They assess the country's investment attractiveness by different groups of indicators that are almost unrelated. Also, the assessment of the investment attractiveness of the country is carried out using a cumulative assessment of the investment attractiveness of sectors of the national economy, namely the profitability of the industry, the prospects of the industry and investment risks [3].

The next step of investors will be to assess the investment attractiveness of various enterprises based on existing approaches that exist in international and domestic practice. Each investor chooses the most appropriate approach depending on what result from the investment resources he wants to get. At the same time, when it comes to attracting foreign investors, the concept of investment attractiveness should be considered as an indicator of international investment attractiveness. Determination of the international investment attractiveness of the object of investment is based on the determination by investors of the feasibility of capital investment, the choice in the purchase of alternative objects and the purchase of shares of individual enterprises [9].

Based on a comparison of the advantages and disadvantages of each approach, the most appropriate to apply to assess the investment attractiveness of Ukrainian enterprises, in our opinion, are the approaches based on financial analysis, as they are more accurate and specific because they are specific and do not require significant costs time. These approaches focus on the areas of investment and components of investment attractiveness.

When assessing the investment attractiveness of the enterprise, domestic scientists identify the following approaches [11]:

- analysis of financial performance of the enterprise;
- a comprehensive approach that takes into account other aspects of the operation of the entity and evaluates the company from various angles;
- market approach, which assesses the attractiveness of the company's securities and analyzes stock market indicators;
- cost approach, the main criterion in assessing the investment attractiveness of the enterprise which is the growth of its value.

Most scholars consider a simple and convenient approach based on the analysis of the financial condition of the enterprise. When applying this approach, a comprehensive assessment of the current situation of

the enterprise. But such an assessment does not reflect the prospects for development and improvement of the results of the analyzed enterprise. Investors are interested in the results they expect from the company in the future, not the past or present results of its work.

The authors of the integrated approach assess the investment attractiveness of the enterprise taking into account the prospects for the development of the investment object and not one-sidedly. The main factors of investment attractiveness are the financial condition, available equipment and the level of technology used. Quite interesting and common is the practice when an investor invests investment resources in a loss-making enterprise with outdated technology, equipment, fixed assets. And the reasons for this decision are the prospects of the market, the brand of the company, image and more.

Assessing investment attractiveness can take into account intangible assets, as the availability and development of intangible assets can significantly affect investment attractiveness. But sometimes there is no relationship between non-financial indicators and the expected results of their implementation, which leads to incorrect assessment of the investment attractiveness of the enterprise.

Currently, several approaches are known, which are used to give monetary estimates of the value of the business enterprise:

- income approach;
- asset based approach;
- comparative approach (market approach).

The cost approach is based on indicators, the choice of which depends on the type of investor and his motivation, as well as the horizon of the assessment [11].

It is important to note that Ukrainian legislation provides an approach to assessing the investment attractiveness of the enterprise by calculating an integrated indicator of the property status of the enterprise, financial stability, liquidity of assets, profitability of the invested object and business activity. This approach is considered in the “Methodology of integrated assessment of investment attractiveness of enterprises and organizations” [2].

This approach to determining investment attractiveness, provided by Ukrainian law, does not fully meet the needs of investors in unbiased, objective and sufficient information to make investment decisions.

Therefore, in order to increase the investment attractiveness of enterprises in Ukraine, the following areas should be followed to increase the international investment attractiveness of enterprises [10]:

1. Minimize costs – set the optimal value of production.
2. Implement an active marketing policy – introduce advertising through various sources and expand the geography of sales promotion.
3. Follow the strategic partnership – partner countries.
4. Carry out technological restructuring – optimization of the production process.
5. Accelerate cash flow – reduce the amount of cash payments and conduct timely collection of revenue.
6. Risk management – conduct regular assessments of probable damage and make decisions on potential risk management.
7. Unity of staff – to encourage the cooperation of employees of different departments.
8. Expand the model range – to develop new products in high demand.
9. Improve business process management systems – improve the system of planning, accounting and control of key performance indicators of the enterprise.
10. Maximize the realization of export potential – take an active part in tenders and diversify products within the market.

The above directions of increasing the international investment attractiveness of the enterprise are not characterized as impossible, they are real and can be used by Ukrainian enterprises, it only takes time to implement them. Ukraine needs to form the international investment attractiveness of the company to:

- to ensure the competitiveness of products and improve their quality; structurally restructure production; to create the necessary raw material base for the effective functioning of enterprises; solve social problems;
- to attract the necessary investments to ensure the effective functioning of enterprises, their stable condition for further expansion and development of production;
- restore fixed assets; to increase the technical level of labor and production, etc.

Another way to increase the investment attractiveness of the subject Entrepreneurship is the use of credit ratings. Based on them systems of

diagnostics and management of investment attractiveness are created enterprises, namely:

1) Analysis of factors, events and deviations that affect credit company rating. The sensitivity of various influences is considered and estimated factors on the rating of enterprises, the degree of deviations of data is estimated indicators as a measure of risk for the analyzed factors;

2) Benchmarking of market segments, which is to conduct comparative analysis of the investment attractiveness of the enterprise from the reference attractiveness;

3) Forecasting credit ratings and investment attractiveness, as well as its individual factors, as well as evaluation and comparison of alternative scenarios for increasing investment attractiveness;

4) Diagnosis of possible changes in solvency on weak signals. Assessment and scenario forecasting of possible negative weak changes private credit rating indicators, as well as the use of received ratings in early risk warning systems;

5) Analysis of the strengths and weaknesses of enterprises for different investors. Identify the strengths and weaknesses of the company to find new ones opportunities to increase investment attractiveness;

6) Making management decisions to implement the chosen strategy increase investment attractiveness.

To increase the investment attractiveness of enterprises, developed scheme of analysis, which consists of three blocks that are interconnected consecutive connections: information block, analytical block and block management.

In each of these blocks the basic procedures and tasks necessary for development of tools and its introduction in administrative tasks of the enterprise are realized.

Based on the analysis of all approaches to assessing the investment attractiveness of the company, developed in domestic and international practice, we found that most of them are based on financial analysis or integrated assessment of investment attractiveness of the company, but there is no single approach that would facilitate investors decision-making process.

Conclusions

Today, the investment attractiveness of the company plays one of the main roles in the development of the company and increase its competitiveness in the market. In order for an investor to decide which company to invest in, he needs information about the strengths and weaknesses of the company, prospects for its further development and the ability to ensure the highest efficiency of investment.

Investment attractiveness is an integral indicator that characterizes the feasibility of investing in a particular object from the standpoint of a particular investor. Existing methods of assessing investment attractiveness involve the calculation of an integrated indicator based on the coefficients of property status, liquidity and solvency, financial stability, business activity, taking into account their relative importance and the level of compliance with regulatory values and dynamics. In modern conditions, research in this area does not lose its relevance, as the correct choice of investment object is one of the prerequisites for obtaining the desired effect in the future.

Investment attractiveness of the enterprise is a set of quantitative and qualitative indicators, which provide an in-depth analysis of the enterprise to form a positive impression of the investor and stimulate the desire to invest, as well as to identify problem areas and develop measures to address shortcomings. As for the process of managing the investment attractiveness of the enterprise, it is a procedure for generating solutions to increase the level of investment attractiveness. The main purpose of management is to find the most effective methods of implementing an investment strategy for integration into the economic activity of the enterprise. The master's dissertation also considers the tasks, functions, principles and stages of managing the investment attractiveness of the enterprise.

Investment attractiveness management should be carried out with the help of modern tools and meet the demands of investors. Such tools defined branding and formation non-financial reporting enterprise (report with sustainable development). Successful branding helps to raise recognizability companies to create positive image as well to raise trust all groups stakeholders to the enterprise. Preparation reporting with sustainable development requires long training that includes gathering data, conducting research, construction cards stakeholders, metrics development, analysis business processes and many another. However, it is thanks to

this leadership companies maybe review your goals and adjust direction development enterprises if necessary. Except this non-financial reporting gives I can to highlight all see influences that carries out enterprise: economic, environmental and social.

Depending on the purpose of assessing the investment attractiveness of the enterprise, you can use techniques based on the analysis of financial indicators, based on expert assessments or by ranking and ranking. The set of indicators for analysis is selected by enterprises independently depending on their specialization.

The main requirement for any method of determining the level of investment attractiveness is the ability to interpret the information obtained and make effective and appropriate management decisions based on certain indicators, both by the investor to invest and by the recipient company to increase its investment rating.

Thus, taking into account the management of investment attractiveness of internal and external factors will allow the company to effectively manage them to increase its investment attractiveness, and the investor – to assess investment attractiveness in order to carry out investment activities.

The proposed system of criteria for assessing the investment attractiveness of the enterprise, based on the assessment of the impact of key factors, allows to form a basis for decision-making on investment. When assessing the investment attractiveness of the enterprise, it is advisable to use an approach based on fuzzy logic, which allows you to assess not only quantitative but also qualitative indicators. It is possible to form a set of indicators in accordance with the needs of the investor. Approbation of the proposed approach to assessing the investment attractiveness of the enterprise was carried out on the example of PJSC “PlasmaTech”, determined the level of its investment attractiveness. This approach makes it possible to significantly increase the level of objectivity and completeness of the results of assessing the investment attractiveness of the enterprise.

According to our observations from the analysis, Harrington’s function for PlasmaTech PJSC in 2018 corresponds to a “good” level of investment attractiveness, in 2019 – a “good” level of investment attractiveness, in 2020 – “unsatisfactory” investment attractiveness.

It should be noted that the conclusions fully confirm the results of the assessment of the investment attractiveness of the company by traditional

valuation methods, which are given in the previous sections. Therefore, the proposed method of assessing the level of investment attractiveness of the company on the basis of the desirability function is reliable.

The proposed system of criteria for assessing the investment attractiveness of the enterprise, based on the assessment of the impact of key factors, allows to form a basis for decision-making on investment. When assessing the investment attractiveness of the enterprise, it is advisable to use an approach based on fuzzy logic, which allows you to assess not only quantitative but also qualitative indicators. It is possible to form a set of indicators in accordance with the needs of the investor.

In-depth digitalization of the researched enterprise, in particular market-oriented, is offered, namely optimization and updating of the software and updating of the official site of the enterprise. It is concluded that the best option for PJSC “PlasmaTech” is to create a large online store that will correspond to the amount of UAH 85,700. Based on the analysis of the software market, the optimal solution for the researched company is the choice of software from SOFTCOM with the product BAS ERP, which corresponds to the amount of UAH 180,000.

Also, based on the novelty formed on the basis of the study of foreign experience in stimulating investment attractiveness, a range of options was formed and improved, in particular:

- to ensure the competitiveness of products and improve their quality; structurally restructure production; to create the necessary raw material base for the effective functioning of enterprises; solve social problems;
- to attract the necessary investments to ensure the effective functioning of enterprises, their stable condition for further expansion and development of production;
- restore fixed assets; to increase the technical level of labor and production, etc.

References:

1. Balats'kyj O. F., Telizhenko O. M., Sokolov M. O. (2014). *Upravlinnia investytsiiamy: navch. posib.* Sumy: VTD «Univertsytets'ka knyha», 232 p.
2. Bokovets' V. V., Mishko N. A. (2015). *Investytsijna pryvablyvist' pid-priemstva. Menedzhment XXI stolittia: suchasni modeli, stratehii, tekhnolohii: zbirnyk naukovykh prats' II Vseukrains'koi praktychnoi internet-konferentsii 16 zhovtnia 2015 r.* Vinnytsia, pp. 302–305.

3. Bocharov V. V. (2002). Upravlinnia hroshovym obihom pidpriemstv i korporatsij. Moscow: Finansy i statystyka, 144 p.
4. Vakaliuk V. A., Balkovs'ka V. V. (2018). Teoretychni aspekty formuvannia efektyvnoi systemy upravlinnia innovatsijno-investytsijnoi pryvablyvosti pidpriemstva. *Hlobal'ni ta natsional'ni problemy ekonomiky*, vol. 23, pp. 165–168.
5. Veb-studiiia FINE. Retrieved from: <https://fineagencyy.com/ua/web.html>
6. Hajduts'kyj A. (2004). Metodolohichni aspekty investytsijnoi pryvablyvosti ekonomiky. *Rehional'na ekonomika*, no. 4, pp. 81–86.
7. Hasij O. V. (2017). Rol' fondovoho rynku u formuvanni investytsijnoi pryvablyvosti aksij pidpriemstv: suchasnyj aspekt. *Ekonomika, finansy, pravo*, no. 8, pp. 10–14.
8. Hrebenikova O. V., Kondrat'ieva O. V. (2018). Kompleksna diahnostyka investytsijnoi pryvablyvosti pidpriemstv kharchovoi promyslovosti. *Infrastruktura rynku*, vol. 26, pp. 103–109.
9. Hrechyna I. V. (2015). Otsinka investytsijnoi pryvablyvosti torhovel'nykh pidpriemstv monohrafiia. Donetsk: DonNUET, 417 p.
10. Hudkova V. P., Kravchenko O. O., Tvoronovych V. I. (2017). Diahnostyka investytsijnoi pryvablyvosti pidpriemstv zaliznychnoho transportu. *Aktual'ni problemy ekonomiky*, no. 2, pp. 95–105.
11. Huliaieva N. M. (2015). Investytsijnyj menedzhment: navch. posib. Kyiv: KNTEU, 220 p.
12. Derzhavnyj komitet statystyky Ukrainy. Retrieved from: <http://www.ukrstat.gov.ua/>
13. Matsybora T. V. (2018). Investytsijna pryvablyvist' ahrarynoho sektoru Ukrainy: rehional'nyj aspekt. *Ekonomika APK*, no. 3, pp. 49–55.
14. Ofitsijnyj sajt Vinnyts'koi oblasnoi administratsii. Retrieved from: <http://vin.gov.ua/news/ostanni-novyny/22029-plazmatek-tse-iaskravyyi-pryklad-uspishnoi-investytsiinoi-polityky-nashoho-rehionu-ta-ambasador-promyslovesti-vinnychchyny-v-sviti>
15. Nakaz Ahenstva z pytan zapobihannia bankrutstvu pidpriemstv ta orhanizatsii «Pro zatverdzhennia Metodyky intehralnoi otsinky investytsiinoi pryvablyvosti pidpriemstv ta orhanizatsii». Retrieved from: <https://zakon.rada.gov.ua/laws/show/z0214-98#Text>
16. Palyvoda K. V. (2018). Problemy formuvannia pryvablyvoho investytsijnoho klimatu iak zasobu podolannia destruktivnykh zmin v ekonomitsi Ukrainy. *Ekonomika & derzhava*, no. 3, pp. 4–9.
17. Pylypenko O. I. (2010). Analiz investytsiinoi pryvablyvosti pidpriemstva: ohliad metodyk. *Mizhnarodnyi zbirnyk naukovykh prats*, vol. 1(13), pp. 324–330.
18. Prohramni produkty BAS vid «TQM systems». Retrieved from: <http://tqm.com.ua/likbez/bas>
19. Prohramni produkty BAS vid «Ukrainian Intelligent Technology». Retrieved from: <https://uit.kiev.ua/product/bas/>

**THE CONCEPT OF ENERGY EFFICIENT
AND ENVIRONMENTALLY SAFE COMPONENTS
OF SUSTAINABLE DEVELOPMENT OF RURAL AREAS
AND AGRICULTURAL ENTERPRISES**

Dina Tokarchuk¹

DOI: <https://doi.org/10.30525/978-9934-26-193-0-9>

Abstract. The subject of research is theoretical and applied aspects of energy management of rural areas and agricultural enterprises. The following research methods were used in the work: functional-structural analysis (for the formation of goals and objectives of the study); system analysis (to structure the conditions and key factors, the choice of methods and tools of managerial influence on energy supply); statistical (for systematization, processing and quantitative analysis of information on energy supply); graphic and tabular (to illustrate patterns and trends); monographic (for deep study of economic phenomena and processes related to energy supply of the economy in general and the agricultural sector in particular); empirical method and qualitative analysis (for the study and evaluation of practical aspects of energy management). The aim of the study is to investigate the formation of a concept of energy efficient and environmentally safe components of sustainable development of agricultural enterprises and rural areas as a whole. The results of the study showed that today the energy efficiency of rural areas and energy supply of agricultural enterprises is an important task, the solution of which should be a priority to ensure energy security at the state level. This requires structural reforms in all areas of energy policy: energy efficiency, the formation of competitive energy markets, diversification of energy supply, increasing the share of alternative energy sources and biofuels in the overall energy supply at the level of enterprises and the state.

¹ Candidate of Economics Sciences,
Associate Professor of the Department of Administrative Management
and Alternative Energy Sources,
Vinnytsia National Agrarian University, Ukraine

1. Introduction

Existing trends in rising world prices for fossil energy resources and further intensification of competition in the world market under the influence of globalization processes have made it urgent to solve the problem of energy resources supply and their efficient use. Therefore, the agricultural sector of Ukraine's economy needs an effective policy aimed at the widespread introduction of energy-saving technologies and organizational and technical measures that increase the efficiency of fuel and energy resources use.

The topical issue of providing the agricultural sector of the economy with energy resources, including renewable ones, is also gaining strategic importance. It is impossible to guarantee sustainable economic development of the country, raising of living standards, solving social problems, establishing and strengthening the economic and political authority of the country in the world community without this.

The issue of alternative energy is increasingly raised when it comes to reducing the cost of ensuring the viability of agricultural enterprises.

The share of bioenergy in Ukraine's energy balance has almost tripled in the last three years alone. Despite the significant number of publications, the issues of energy efficiency in rural areas and energy management of agrarian enterprises using biogas technologies in Ukraine remain insufficiently studied, which led to the urgency of the work.

The aim of the study is to form a concept of energy efficient and environmentally safe components of sustainable development of rural areas and agricultural enterprises.

This aim involves the following tasks:

- substantiation of theoretical principles of energy efficiency and energy supply at macro and macro levels;
- formation of methodical approaches to assessing the effectiveness of energy supply management of enterprises;
- study of the current state of energy supply of Ukraine and the agricultural sector of the economy and strategic ways to improve them.

2. Theoretical principles of energy efficiency and energy supply at micro and macro levels

Today, the definition of energy efficiency is interpreted differently around the world. According to the Law of Ukraine "On Energy Conservation" there

is a definition “energy-efficient products, technology, equipment – products or methods, means of its production that ensure the rational use of fuel and energy resources compared to other options for the use or production of products of the same consumer level or with similar technical and economic indicators” [1]. Moreover, the rational use of fuel and energy resources is defined as one that achieves maximum efficiency.

Actually, fuel and energy resources are treated as a set of all natural and transformed fuels and energy used in the national economy at the current level of development of equipment and technology with a simultaneous reduction of man-made impact on the environment. That is, the energy efficiency of the economy, according to the Law of Ukraine “On Energy Conservation” is “rational use of energy resources compared to other options for use or production of products of the same consumer level or environmental technical and economic indicators”.

O.I. Tsapko-Piddubna noted in her work [2] that the mechanisms of energy efficiency policy implementation are a certain type of policy actions or market interventions that reduce energy consumption and encourage the production of energy efficient goods and services. Summarizing the experience of domestic and foreign enterprises, it should be noted that innovation in the country should be carried out through mechanisms for regulating energy efficiency and energy saving policy, including regulatory and information tools, voluntary agreements on energy efficiency and international cooperation and international commitments. Investment and innovation activities in the energy sector are related to the implementation of the basic principles of state policy on energy conservation through a system of appropriate energy efficiency mechanisms.

Energy efficiency is a criterion for the quality of the economic model of the state, coordinated interaction between economic entities, which should help to improve energy efficiency of production, as it directly affects its profitability and, consequently, their profits. The state is interested in improving the efficiency of energy use by the national economy, as it allows it to increase the tax base and reduce government spending on energy budget institutions, to increase its influence in world markets and increase energy security. Increasing energy efficiency for the population, allows to increase the level of income and reduce the cost of purchasing energy services. For society in general, this is a way to approach the level of sustainable

development, which increases the competitiveness of the region and the country as a whole.

State policy on energy efficiency should be aimed at: meeting the needs of society in conditions of both normal and special condition; technically reliable and safe operation of society's energy supply systems; economic efficiency of functioning of energy supply systems and the energy sector of Ukraine in general; energy efficiency of energy use by society and the national economy; environmentally friendly solution to the impact of energy on the environment and climate; the ability of the state to formulate and implement a policy to protect national interests regardless of existing and potential threats of internal and external nature in the energy sector.

The results of the US Department of Energy's Energy Efficiency Working Group proved that "the energy efficiency cannot be expressed by a single indicator, so there are many approaches to its definition or interpretation as a concept:

- energy efficiency is the necessary level of energy resource consumption to achieve a certain level of well-being (for example, economic, social, human life standards, the state of the natural environment and etc.);

- energy efficiency – an indicator of reverse energy intensity;

- energy efficiency is an indicator that refers to energy intensity, it is a complex system of indicators, the interpretation of which depends on the system for which it is calculated, it is important to monitor the dynamics of these indicators, as well as ensure their dynamic improvement through cost-effective mechanisms (technological renewal and the use of resource-saving technologies, and also, what is even more important, replace the basic technologies of fuel and energy resources with fundamentally new)" [3].

European Commission ("Communication on the Energy Efficiency Action Plan") identifies energy efficiency as a reduction of energy consumption without reducing the use of energy by production and equipment, i.e. it means the rational use of energy resources and alternative energy sources and reducing the overall demand for energy resources in certain areas.

Ukrainian scientists Mitrakhovych M.M., Gerasymchuk I.S., Sukhodolya O.M. [4] distinguish in detail the concepts of energy efficiency and energy saving. The concept of "energy efficiency" (national economy) means the quality of the economy, which ensures the rationality and

efficiency of energy use in accordance with the existing level of economic and cultural development, development of machinery and technology, the dominant worldview and the state development priorities. At the same time, the energy efficiency of GDP is the inverse of the energy intensity of GDP and the lower the energy intensity, the greater the energy efficiency of the country's economy.

Energy intensity of GDP is a generalizing macroeconomic indicator that characterizes the level of consumption of fuel and energy resources per unit of gross domestic product. This indicator is one of the fundamental characteristics of energy efficiency of the economy of the region and the country as a whole.

In our opinion, the conclusion of scientists [5] on the essence of these categories from the standpoint of qualitative and quantitative components is important. Thus, given the difference between the concepts of “energy efficiency” and “energy saving” it should be noted that the concept of “energy efficiency” reflects the qualitative characteristics of the national economy, and the concept of “energy saving” – the effectiveness of reducing quantitative parameters of interaction (energy consumption). The energy saving policy is aimed primarily at fulfilling the quantitative task of energy saving. Energy efficiency policy aims to achieve a quality state of the economy, which is reflected in energy efficiency, and in the initial stages requires the realization of energy saving potential.

Thus, in terms of assessing energy efficiency, economies use the energy intensity of GDP as the most adequate criterion. The energy intensity of GDP, although it reflects the relative efficiency of energy use by the country, but is not considered an absolutely accurate criterion.

The indicator of energy intensity of GDP reflects only the trends of the national economy in terms of energy use, and its dynamics tracks the selected type (energy-saving, extensive) and trends in economic development. The reason for this statement is the fact that the energy intensity of GDP is determined not only by the efficiency of energy use in production or provision of services, but also the structure of industrial production, transport system development and geographical location, climate and other factors. The importance of considering this issue is due to the fact that energy efficiency policy, aimed at shaping the quality of the national economy, goes far beyond energy saving (energy saving

policy) and includes tasks not only to realize energy saving potential at all levels, but also tasks on economic, environmental, energy policy, which allows to evolve in the context of the concept of sustainable innovation development.

Thus, based on the role of energy, fuel and energy complex as a whole in society, their direct and indirect links with the economy, the latter should be considered not only as purely industrial or technical systems, but also as part of more complex economic and socio-political systems. Therefore, they are the most important components of the integral properties of higher-ranking systems. The volume and efficiency of energy production and consumption largely determines the level of development of the country and the welfare of its population.

Human energy consumption has increased approximately 2-3 times every 30 years and continues to increase, albeit at a slower pace in the twentieth century. This gives energy a special character as a branch of the national economy, without the development of which it is impossible to solve the problem of economic development and raising living standards [3].

The key role of the fuel and energy complex in the development of all sectors of the economy and ensuring the life of society is directly related to the energy security of the country.

Energy security is guaranteed, reliable energy and fuel supply, necessary for sustainable operation on economically sound grounds of material production and social sphere in normal conditions, as well as their survival in emergencies [6].

The problems of fuel and energy resources are of particular importance for countries that do not have sufficient own energy resources. The stability of markets is also important for energy exporting countries. Therefore, it is extremely important for the sustainable development of the state to economically weigh the country's potential from the standpoint of the presence (absence) of the country. In this case, it is important to adhere to the following principles (Table 1).

Energy efficiency at the enterprise level is a characteristic of equipment, technology, production or the system as a whole, which indicates the degree of energy use per unit of final product. Energy efficiency is assessed both quantitatively (the amount of energy used per unit of final product) and qualitative (low, high) [7].

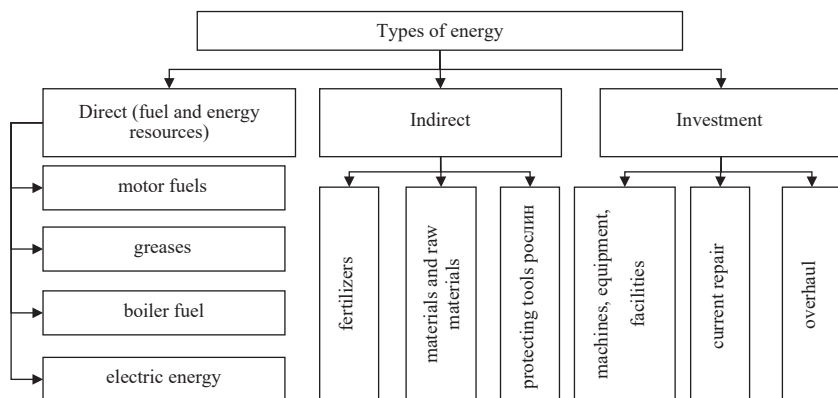

Figure 1. Types of energy used by agricultural enterprises

Source: formed by authors

This classification does not consider natural and climatic energy resources, solar energy, soil energy, etc. Determining the structure of fuel and energy resources makes it possible to identify the main ways to reduce energy consumption. At the same time, the process of efficient energy supply and rational energy consumption should be considered within the functioning of the energy management system of the enterprise.

Energy management is a process aimed at determining and implementing the optimal cost of energy resources and rational ways to achieve them. The purpose of rationalization of energy consumption must meet the following requirements: certainty, clarity, accessibility, compliance with the requirements of objective laws of economic development, compliance with the goals of the highest order [8].

On the other hand, energy saving management is a management system that ensures the operation of the business entity, which consumes only the necessary amount of fuel and energy for production [9].

A.V. Prakhovnyk, V.P. Rozen and O.V. Rozumovsky define energy management as managerial and technical activities of personnel of the facility, aimed at the rational use of energy, taking into account social, technical, economic and environmental aspects [10]. The main goal of energy management is to provide effective ways to implement energy saving strategy of the entity.

Energy management system is part of the overall management system of the enterprise, which includes organizational structure, management

functions, obligations and responsibilities, procedures, processes, resources for the formation, implementation, achievement of energy conservation policy goals [11].

In our opinion, energy management as a component of enterprise management can be interpreted as:

- management actions aimed at ensuring the effective functioning of the energy system of the enterprise and achieving its goals;
- management of the processes of distribution and use of energy resources carried out at the enterprises, providing production of the planned volumes of production (services);
- a way to make management decisions and control their implementation, ensuring the efficient use of energy resources.

The tasks to be solved in the energy management system include: determination of specific goals of energy use of the enterprise; identification of priority of energy use goals, their sequence; formation of the energy strategy of the enterprise; determination of the necessary resources and sources of their provision for the implementation of the energy strategy; establishing control over the implementation of tasks.

In order to formulate management tasks, it is necessary to define the following components: the object of management, the purpose and criteria of management, management influences, constraints on the management process, uncontrolled influences on the object: management tools.

The object of management is the enterprise as a whole, its individual divisions, fuel and energy units (FiEU), as well as the personnel of the enterprise, whose activities are related to the efficiency of energy use, operation, repair and maintenance of equipment. The considered object belongs to the number of complex systems, therefore for its description it is necessary to use not one, but several representations depending on character of the solved problems.

Among the most common representations of this object are:

1. Block diagram of the enterprise, which shows the units of input and output of energy resources (transformer substations, gas distribution points, steam and hot water pipelines), divisions of the enterprise, the largest fuel and energy units, as well as devices for metering and supply of energy resources.

2. Schemes of material flows of the enterprise (flows of energy, raw materials and finished products), which should be presented as oriented graphs, arcs of which are material flows, and devices for their use are the nodes, processing and transportation and storage.

3. Schemes of factory-wide energy and water supply systems, in particular heating, steam supply, gas supply, water supply, electricity supply, air supply, etc.

4. List of the largest FiEU units.

The process of managing energy consumption in an agricultural enterprise is subject to certain restrictions. In the general case, it is necessary to take into account the restrictions of the following nature: planning and production; financial; environmental; technical; regulatory.

The main limitation of the planning and production nature is the actual level of load of the enterprise, which is determined by the availability of product orders and sales. Financial constraints, as a rule, do not allow to fully realize the potential of energy saving at the enterprise, so specific calculations must be performed based on a certain limited amount of funding for energy saving measures. Environmental requirements are imposing stricter restrictions on the volume and chemical and physical composition of products of fuel combustion, water pollution and solid waste, which are inevitable companions of almost any production. As a rule, environmental limitations are an additional incentive for the effective use of energy resources. Technical limitations may be related to compliance with safety and reliability requirements. Management tools include administrative-organizational, technical and program-methodical. Administrative and organizational tools include organizational schemes, orders, job descriptions, provisions on financial incentives for employees and departments, as well as training measures. The technical ones include the following: measurement of computer technology, information transfer, automation of energy and technological processes.

So we can conclude about the importance of energy resources as a driving force of economic development in general and the agricultural sector in particular. Provision of them and their rational use is the key to successful and efficient operation of agricultural enterprises.

3. Methodical approaches to assessing the effectiveness of energy supply management of enterprises

Solving the energy problem, overcoming the energy dependence of Ukraine's economy is closely linked to the successful modernization of the energy supply system, which is considered an integral part of the restructuring of the national economy [12]. One of the prerequisites for the successful implementation of any strategy, including the strategy of energy supply of the enterprise, is a convincing justification for the need for changes in the implementation of this strategy. Management of the strategy implementation process is considered successful if the company achieves strategic goals, planned values of strategic indicators and generally implements a long-term strategic plan.

The development of the strategy of energy supply management of an agro-industrial enterprise should be preceded by an assessment of the quality of management of the enterprise in general and its energy subsystem in particular [9].

In modern economic conditions, rapid changes in the environment, exacerbation of external factors, including macro-level factors, on the level of energy security of enterprises require the construction and operation of quality energy management systems, as it affects the efficiency of these enterprises, their competitiveness and viability. A great role is given to the practical solution of a set of issues of organization, methodology and implementation of new approaches to assessing the quality of energy management system of the enterprise in fulfilling this task, especially in the strategic context.

In determining the purpose and program of analysis of the energy management system the next is taken into account: the essence of the problem to solve which is the analysis (increasing the level of energy security and energy efficiency of the enterprise); features of the object under analysis (energy systems of the agro-industrial complex); availability of a base of comparison (use of foreign experience of energy supply of enterprises or experience of advanced enterprises in the industry); the reality of providing the necessary information; methodological support of analysis; performers of analytical work (personnel and technical support); deadlines, etc.

The results of the analysis are the basis for assessing the materiality of the managerial impact on the performance of the managed object, i.e. the energy supply system of the enterprise, as well as the basis for tactical and

strategic measures to improve management to ensure strategic direction and increase the effectiveness of energy supply management [13].

It should be noted that the efficiency of energy supply management of an agro-industrial enterprise is influenced by both internal and external factors. Of course, the quality of management will be largely determined by the effectiveness of the energy security system formed in the enterprise.

When assessing the effectiveness of energy management of the enterprise, it is impossible to ignore the innovation and investment components of the development of the energy system of the enterprise. I.G. Gurnyak and Z.V. Yurynets even introduce such a concept as “innovative potential of energy saving”, which is interpreted as the ability of management to “develop innovative activities for the implementation of projects for technological modernization of enterprises to reduce energy consumption, due to requirements for reliability and energy security” [14]. The use of alternative energy sources is relevant in modern conditions, as noted above, especially for agro-industrial enterprises, which is impossible without the intensification of innovation and investment activities. Thus, the criterion of innovation and investment activity of the enterprise should be used to assess the effectiveness of energy supply management system of the enterprise.

In our opinion, the assessment of the effectiveness of energy supply management is advisable to do on the basis of analyze of the dynamics of the three-component quality indicator of energy supply management, which takes into account such components as internal energy security, the level of threats to the external environment to the energy security of the enterprise, which is expressed by the degree of risk of adverse scenarios of events in the energy market and the level of innovation and investment activity of the enterprise in the field of energy saving.

The three-component indicator of quality assessment of energy supply management of an agro-industrial enterprise is proposed to be determined by functional dependence according to the formula:

$$KES P = f(B, Z, I) \quad (1)$$

де B – the internal assessment of the level of energy security of the enterprise;

Z – the level of threats to the external energy security of the enterprise;

I – the level of innovation and investment activity of the enterprise in the field of energy saving.

The given three-component complex indicator of an estimation of quality of management of power supply of the enterprise is defined on functional dependence:

$$B, Z, I = 1 \quad (2)$$

if the actual value of indicators B, Z, I is greater than or equal to their limit value (sufficient or desired), the value of the indicator is considered sufficient, i.e. the quality of management is satisfactory;

$$B, Z, I = 0 \quad (3)$$

if the actual value of indicators B, Z, I is less than their limit value (sufficient or desired), the value of the indicator is considered insufficient, i.e. the quality of management is unsatisfactory [13].

As sufficient or desirable values of indicators in assessing the level of efficiency of energy supply management of the enterprise values can be used that are identified through the study of progressive foreign experience, industry averages, indicators of leading companies in the field of energy saving, indicators defined as strategic guidelines for enterprise.

The energy security system of the enterprise, as mentioned above, is characterized by the complexity and diversity of phenomena and requires the study of a large number of indicators. In such conditions, the level of energy security of the enterprise can be assessed using a set of indicators based on such characteristics as stability, maneuverability, flexibility, reliability, efficiency, controllability.

To determine the basic indicators of the internal component of energy security of the enterprise, we use the list proposed by V.O. Samborsky [15], from which we exclude those indicators, that characterize the level of threats to the external environment to energy security of the enterprise (Table 2).

In the system of energy security assessment, indicators are divided into stimulants, i.e. have a direct impact on strengthening the energy security of the enterprise (for example, self-generation indicator), and disincentives, which have the opposite effect on security (for example, energy component indicator in costs). This means that the higher the level of the disincentive indicator or the higher the rate of its growth, the lower the level of security of the enterprise.

**Indicators of the internal component
of energy security of the enterprise**

Indicator	Characteristic
1. Indicators that characterize the state of energy supply and use	
1.1. Indicator of the level of energy losses in the networks of the enterprise	The ratio of the amount of lost energy in the enterprise network to that received from the energy supply organization
1.2. Indicator of the amount of energy supply to the enterprise	The ratio of the actual amount of energy received per month to the planned (declared)
1.3. Indicator of specific energy consumption of products	Indicator of specific energy consumption of products
1.4. Indicator of the level of payment for energy consumption	The ratio of the amount of payment by the enterprise for energy consumed to the amount issued by the energy supply organization
2. Indicators that characterize the structure of energy resources of the enterprise	
2.1. Depreciation indicator of fixed assets of the enterprise that produces and consumes energy	The ratio of the amount of accrued depreciation to the original cost of fixed assets
2.2. Price balance indicator	The ratio of the price index for enterprise products to the energy price index for the period
2.3. Indicator of the energy component in costs	The share of energy costs in the total costs of the enterprise
3. Indicators characterizing the use of energy-saving technologies	
3.1. Self-generation indicator	Share of own generation and secondary sources in total energy consumption
3.2. Indicator of efficiency of energy saving activity	The ratio of enterprise profits to the cost of energy saving measures
3.3. Wear indicator of power equipment of the enterprise	The ratio of the cost of wear of energy equipment of the enterprise to its original cost
3.4. Indicator of the share of costs for energy saving measures	Indicator of the share of costs for energy saving measures
3.5. Indicator of specific CO ₂ emissions per unit of output	The ratio of CO ₂ emissions to total output

Source: [12]

The next step in diagnosing the level of energy security of the enterprise is to control the compliance of indicators with limit values. Therefore, it is necessary to carry out the procedure of rationing of these indicators using their limit values (normative or desirable).

The rationing of stimulus indicators according to their threshold level is as follows:

$$y_{ij} = \frac{x_y}{x_{e(n)}}, \quad (4)$$

where y_{ij} – the normalized i -th indicator in the j -th population;
 $x_{e(n)}$ – the limit value of the indicator.

The rationing of disincentives according to their threshold level is as follows:

$$y_{ij} = \frac{x_{e(n)}}{x_y}. \quad (5)$$

The rationing of indicators that characterize the level of energy security of the enterprise by the limit values makes it possible to assess the level of effectiveness of management of safety parameters.

The regulatory level will be characterized by zero deviations, i.e. at this level of management efficiency, all indicators that characterize the level of energy security of the enterprise will meet their limits or be better than them. In the absence of generally accepted or industry normative values, the best indicators in the industry or at the given enterprise for a number of years are accepted as the last [16].

The integrated indicator of energy security is determined as follows:

$$I_{EE} = \sum_{i=1}^n K_i \times k_{bi} \quad (6)$$

where K_i – the average level of the indicator for the i -th group of energy security indicators;

k_{bi} – the weighting factor of the i -th group of energy security indicators, determined by experts.

The level of threats to the external energy security of the enterprise can be determined by expert methods or using indicators, such as:

– indicator of the state of the energy balance of the region (the ratio of energy produced or extracted energy resources in the region to that consumed);

- indicator of reliability of energy supply (characterizes the share of restrictions on energy supply in the volume of consumption);
- indicator of the quality of energy supply to the enterprise (relative difference between actual voltage and rated voltage, between actual heat dissipation and rated heat dissipation, etc.);
- indicator of growth of energy tariffs (the ratio of the average energy tariff for the previous period to the current value of the tariff), etc. [16].

The level of innovation and investment activity of the enterprise in the field of energy saving can be assessed by the following indicators:

- indicator of investment activity (the ratio of the amount of investment in energy saving to the amount of net profit of the enterprise);
- indicator of innovation activity (share of expenditures on innovations in the field of energy saving in the total amount of expenditures on energy saving measures);
- indicator of efficiency of investment activity (ratio of savings on energy costs to costs of energy saving measures);
- indicator of efficiency of innovative activity (ratio of saving of expenses on energy resources to expenses on innovations in the field of energy saving), etc.

Analytically processed material obtained during the assessment of the level of efficiency of the energy supply system management of the enterprise, it is advisable to use to identify advanced methods and “bottlenecks” in the management process; development of plans for the development of the management system taking into account the priority areas and the real capabilities of the enterprise; finding out the reasons for inconsistencies and identifying reserves to improve the efficiency of management of the energy supply system of the enterprise; diagnostics of prospects of development of energy supply system of the enterprise and its separate elements.

The application of the proposed methodological approach to assessing the level of efficiency of energy supply management of the enterprise will form an analytical basis for developing an energy supply strategy aimed at improving both energy efficiency and overall efficiency of the enterprise.

4. The current state of energy supply of Ukraine and the agricultural sector of the economy and strategic ways to improve them

The efficiency of fuel and energy resources use in the economy of any country and international comparisons are based on the energy intensity of gross domestic product (GDP). This indicator is determined in kilograms of oil equivalent per \$1,000 of GDP. According to the State Statistics Service of Ukraine and the Ministry of Energy, Ukraine has a tendency to reduce the energy intensity of GDP, but, this indicator is quite high being compared to other countries. According to 2020 data, the energy intensity of Ukraine's GDP exceeds the energy intensity of Germany's GDP 4 times, Poland's – 3.2 times, the United States' – 2.8 times, China's and Russia's – 1.8 times, Italy's and Spain's – 4.8 times, Switzerland's – 6.5 times [17].

High energy intensity of GDP inhibits the growth of the country's economy, makes domestic goods and services more expensive and, of course, less competitive. The National Energy Efficiency Action Plan, approved in November 2015, envisages a 9% reduction in Ukraine's energy intensity by 2020. At the same time, Eastern European countries plan to reduce the energy intensity of GDP by 20% over the same period, the United States – by 25%, China – by 33%, Russia – by 40% [18].

About 24% of oil was extracted since Ukraine's initial geological reserves. Due to the fact that a significant part of the explored reserves are heavy to extract, almost 800 million tons of oil reserves remain in the subsoil and can not be extracted by traditional technologies. Great hopes are placed on the waters of the Black and Azov Seas, where unexplored oil reserves with condensate are estimated at 220 million tons. The depth of oil refining at domestic plants is 52-54%. This indicator exceeds 80% in the EU for comparison. Thus, Ukrainian oil refineries are not competitive enough in modern conditions. Their technological base is not able to provide the country with high quality petroleum products in the required volumes. To change the situation for the better, it is necessary to harmonize production with market needs. This requires significant investment [19].

The peak of oil and natural gas production in Ukraine was in 1970–1975. Subsequently, there was a sharp decline in production to 4 million tons of oil and 18-20 billion m³ of natural gas per year. Since 1995, there has been a stabilization and some increase in production rates.

Providing Ukraine's economy with energy resources is shown in Table 3.

Table 3

Providing Ukraine's economy with energy resources

Type of fuel	2016	2017	2018	2019	2020	2020 to 2016, +/-
Providing Ukraine's economy with its own energy resources, %						
Coal & peat	68.3	51.3	51.3	52.2	53.6	-14.7
Grude oil	6.9	6,6	7.0	7.4	7.4	0,5
Oil products	0	0	0	0	0	0,0
Natural gas	45.3	46.2	49.2	48.7	47.4	2,0
Production, thousand tonnes of oil equivalent						
Coal & peat	22869	13696	14556	14446	12753	-10116
Grude oil	2304	2208	2341	2478	2476	172
Oil products	0	0	0	0	0	0
Natural gas	15175	15472	16487	16318	15856	681
Total production	40348	31376	33384	33242	31085	-9263
Import, thousand tonnes of oil equivalent						
Coal & peat	10617	12993	13806	13239	11036	419
Grude oil	527	1331	1333	1341	1815	1288
Oil products	9155	9520	10155	10383	10204	1049
Natural gas	8809	11262	8459	9506	7386	-1423
Total import	29108	35106	33753	34469	30441	1333

Source: formed by the author according to [20]

The main factors that determine the high energy intensity of production and life in Ukraine include: inefficient and wasteful consumption of energy resources, in particular, due to non-compliance with current requirements for technology and equipment; obsolescence of fixed assets and communications and unsatisfactory pace of their renewal; significant losses of energy resources, especially natural gas, heat and electricity during their transportation, storage and distribution; low level of introduction of energy efficient technologies and equipment (introduction of new technological processes, in particular, low-waste, resource-saving and non-waste, is carried out by no more than 3% of the total number of industrial enterprises); significant technological lag of Ukrainian industry from the level of developed countries; high level of depreciation of fixed assets in the economy (74.9%) and a corresponding increase in the specific costs of energy resources for the production of a number of important products in the

most energy-intensive industries; insufficient use of industrial processing of waste, in particular solid household waste.

According to the Energy Trilemma Index [21], calculated by the World Energy Council (WEC), Ukraine in 2020 ranked 50th among 108 countries. The WEC index is based on a comparative analysis of the energy situation in the country and is based on three factors: Energy Security, Energy Equity and Environmental Sustainability. Depending on the success in each direction, the country is assigned a rating from A to D. Ukraine's rating is ACB. According to the compilers of this rating, the worst thing in Ukraine is with the environment, as well as with the overall efficiency of the industry. Switzerland became the leader of the WEC ranking. In addition, Sweden, Denmark, France, Austria, Great Britain, Canada, Norway, New Zealand and Spain were in the top ten in terms of energy resistance index. Only eight countries received the highest AAA energy resilience rating – Switzerland, Denmark, Austria, the United Kingdom, France, Germany, New Zealand and Italy.

Exceeding the energy intensity of the Ukrainian economy by three or four times the corresponding indicators of economically developed countries makes Ukraine extremely sensitive to the conditions of natural gas imports and makes it impossible to guarantee normal living conditions for citizens and public institutions.

The main factors that hinder the current decline in energy intensity of GDP are: high degree of physical depreciation of fixed assets and technological backwardness in the most energy-intensive industries and housing and communal services; inefficiency of natural monopolies; high level of energy losses during their transmission and consumption; limited incentives to reduce energy consumption in the absence of meters; low level of introduction of energy efficient technologies and equipment both in industry and among the population.

There is no doubt that without the modernization of the economy on an energy efficient basis in Ukraine there are no prospects. Reducing the energy intensity of the economy should become one of the priority goals of the state policy of our country.

Becoming a full member of the European Energy Community in 2011, Ukraine has committed itself to implementing relevant EU decisions in the energy sector: developing and bringing into line European regulatory

framework, creating an integrated energy market and legislation to strengthen energy security, attracting investment, improving the environment, etc.

Ukraine has adopted a number of Laws: “On the Electricity Market”, “On Heat Supply”, “On Combined Heat and Electricity Production (Cogeneration) and Use of Waste Energy Potential”, “On Energy Conservation”, “On Housing and Communal Services”, “On alternative energy sources”, “Energy Strategy of Ukraine until 2035”, which regulate the operation of electricity and heat supply systems.

In pursuance of Directive 2010/75/EU on industrial emissions in 2017, the Cabinet of Ministers of Ukraine approved a National Plan to reduce emissions from large combustion plants [22]. Also, the energy equipment of countries that are or aspire to become members of the European Union must meet the requirements of the European Directive 2012/27/EU on energy efficiency, which recommends the introduction of high-efficiency cogeneration to dispose of waste heat generated in electricity generation [23].

Relevant regulatory measures are being taken by EU countries to implement these directives. Examples of such regulatory measures taken in European countries at the level of central government are:

- adoption of the Federal Law (Germany) on cogeneration, which guarantees thermal power plant owners a surcharge on the price of cogeneration from 0.56 cents per kWh to 5.11 cents per kWh, depending on the year facilities, degree of modernization and size of the installation, as well as the technology used);
- exemption of the power plant from paying the environmental tax on fuel used for combined electricity generation;
- exemption from the environmental tax of own electricity consumption of thermal power plant.

In order to resolve the crisis in the energy system of Ukraine, the Ministry of Energy approved a new Forecast Energy Balance on April 28, 2020. Energy balance involves a proportional reduction in electricity production by all types of generation: nuclear, hydro, thermal. The forecast growth of generation from renewable energy sources has also been adjusted. The share of thermal power plant production, which performs the function of providing heat supply during the heating season, has remained almost unchanged.

The new balance is aimed at:

– Ensuring a safe schedule of nuclear power plants. In conditions of falling demand, the power units of nuclear power plants cannot operate at maximum constant load throughout the day. Until recently, NEC “Urenergo”, which performs scheduling functions, was forced to unload them at night, as well as on weekends and holidays. Experiments with regular changes in the load of nuclear power units are extremely dangerous. Therefore, together with the representatives of NNEGC “Energoatom” and NEC “Ukrenergo”, the optimal generation rates of nuclear power plants were proposed for the safe operation of nuclear units.

– Ensuring the implementation of delayed repairs of power units of nuclear power plants. In the last 5 years, NNEGC “Energoatom” has been faced with maximum tasks in the production of electricity, which forced the state-owned company to postpone some repairs. Taking into account the service life of Ukrainian nuclear power plants, all delayed repair works must be completed in 2020 so that NNEGC “Energoatom” can continue to fulfill its social obligations under the PSO mechanism during the heating season 2020/2021.

– Ensuring reliable operation of the country’s energy system. An important element of the power system is to ensure sufficient balancing power. Recently, due to falling consumption as well as low water levels for hydropower plants, the available amount of shunting power has been critically low. This threatened the emergence of accidents during periods of change in the daily phases of consumption. In particular, according to NEC “Ukrenergo”, the gap between the evening peak and the night fall has increased from 4 to 4.8 GW in recent days.

– Ensuring the sustainable operation of the coal sector. Due to the crisis of the industry, warm winters, increased coal imports and the emergence of electricity imports. Consumption of Ukrainian coal was almost non-existent. As a result, a record amount of coal is stored in coal depots, most of the mines have been shut down, about 40,000 miners are in forced downtime, and tens of thousands of families have lost more than half of their income. The coal industry is one of the most important elements of Ukraine’s energy independence and therefore it is extremely important to ensure the smooth operation of domestic coal companies [24].

The introduction of an updated Forecast Energy Balance is the first step in overcoming the energy crisis. In its next anti-crisis steps, the Ministry of Energy plans: to reform the PSO system in order to provide NNEGC “Energoatom” with greater opportunities to participate in market segments, to obtain market value for its own electricity; to solve the problem of increasing RES and the burden on SE “Guaranteed Buyer” “green tariff”; to solve the problem of debt in the electricity market and stabilize the work of all its segments.

Providing agro-industrial enterprises with energy resources remains an important issue. Of the total amount of direct energy resources, the agro-industrial complex annually consumes: natural gas – 4.1 billion cubic meters (6% of national gas consumption), including agricultural enterprises – 0.7 billion cubic meters, food industry – 3.5 billion cubic meters of gas; electricity – 4.97 billion kW·hours (4% of national electricity consumption), including agricultural enterprises – 2.85 billion kW·hours, food industry enterprises – 2.12 billion kW·hours; oil products – 1.4 million tons of diesel fuel and 400 thousand tons of gasoline [20].

Thus, we can conclude that the agricultural sector of the country’s economy is one of the main consumers of fuel and energy resources. The share of fuel and energy resources in the cost of agricultural products is quite significant (exceeding 12% in the agricultural sector as a whole and 17% in crop production). Moreover, it is constantly rising following rising oil prices. This is in line with global trends.

With the proclamation of Ukraine as an independent state, the use of fuel and energy resources by the agro-industrial complex has decreased (more than twice). This is due to the reduction of sown areas compared to 1990 (almost 20%), technological operations in crop production, truck fleet (from 296 to 133 thousand), tractors (from 495 to 201 thousand) and combines (from 107 to 44 thousand), the reduction of the volume of livestock production, the use of resource-saving technologies, as well as a more careful attitude to the use of energy resources. This has led to some improvement in the efficiency of energy use in the agricultural sector of the country’s economy.

The range of fuel for tractor engines on the territory of Ukraine is large. This is due to the fact that with the advent of independence, domestic fuel standards have emerged, while the standards of the Soviet era are in force,

which usually have international status within the CIS countries. In addition, a large amount of fuel is imported from post-Soviet and Eastern European countries (almost 30% of the total), because Ukraine cannot provide for itself due to lack of raw materials (oil).

There has been a slight increase in the amount of diesel fuel used in recent years. This is due to the fact that tillage, sowing and harvesting works use agricultural machinery, which works mainly on diesel fuel. As the gross output of agriculture increases every year, the consumption of diesel fuel by the agricultural sector of the economy is growing accordingly.

According to scientists from the Institute of Agrarian Economics (Ukraine), agricultural enterprises have reduced the use of motor gasoline as a whole and for agricultural work by 12 times compared to 1990.

This was facilitated by three main factors: 1) savings of agricultural enterprises based on the principles of private property, due to radical changes in the attitude to their own costs and reducing the cost of production; 2) development of the practice of involving in recent years in the performance of transport works of third-party organizations, rather than their performance by the enterprises themselves; 3) the spread of the trend of selling the crop on a free-tick, free-elevator, sometimes – free-field. In this case, the transport costs are paid by the buyers of agricultural products.

Table 4

Final energy consumption in Ukraine and in its agriculture, forestry and fishing for 2016–2020

Indicator	2016	2017	2018	2019	2020	2020 to 2016, +/-
Total final energy consumption, thsd. toe	51649	49911	51408	49665	47821	-3828
Agriculture, forestry and fishing, thsd. toe	2143	1847	1880	1882	1671	-472
% of total	4.1%	3.7%	3.7%	3.8%	3.5%	-0.6 p.p.

Source: formed by the author according to [20]

The consumption of fuel and energy resources per 1 hectare of agricultural land has also decreased in 4 times over the last twenty years. Significant increases in fuel prices for both motor gasoline and diesel fuel

(Figure 2) and the development of new forms of ownership have led to increased efficiency in the use of energy resources in agriculture.

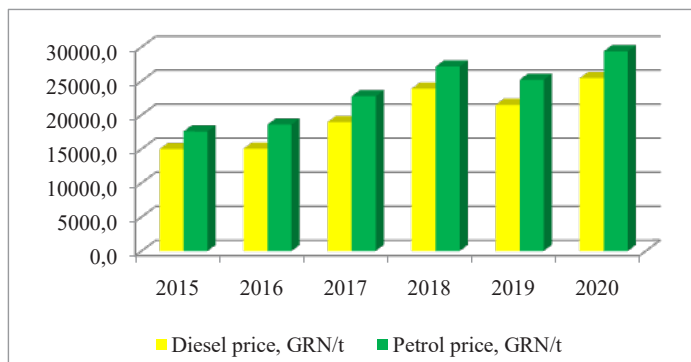

Figure 2. Purchase price of diesel fuel and gasoline by agricultural enterprises of Ukraine, 2015–2020

Source: formed by the author according to [20]

The main difference between gasoline and diesel fuel, which are produced in accordance with domestic standards and specifications, from similar products in the EU and the Russian Federation – is a higher (from 30 to 400%) concentration of lead and sulfur (up to 100%), which negatively affects on environmental performance and engine life. But it should be noted that the production of cleaner fuels is more expensive. The state adjusts their competitiveness by the amount of excise duty. Ukrainian oil refineries produce fuel of weighted fractional composition (UFS brands and others). Its use leads to deterioration of technical, economic and environmental performance of diesel engines. The results of operational experience indicate negative consequences: the specific fuel consumption increases (by 2-4%); costs for maintenance of fuel filters increase (almost 2 times); the service life of engine oils and engine life is halved; smoke (10-15%) and sulfur oxide emissions increase.

Natural gas is a resource on which the well-being of Ukrainians depends. However, obtaining this resource is not easy. Hydrocarbon production requires considerable resources and time. In addition, the situation on the world energy market makes us think about when it is more profitable to

increase production. Natural gas production in Ukraine in 2020 amounted to 20.2 billion cubic meters, which is 1.9% less than in the previous year. Over the past six months, gas prices in Europe have fallen by about 50%. This is one of the sharpest falls in the last decade. The main reason is the increase in the volume of American gas on the European market.

Natural gas is consumed by agricultural enterprises as an energy source and in the technological processes of crop and livestock production. A significant consumer of this type of fuel are elevators, which use it in the process of drying grain. Elevator gas consumption has some nuances. First, it is seasonal and limited to September-December. Second, it is difficult to predict because it depends on factors such as weather. It is in the latter that the biggest nuance lies, as in March 2019 Ukraine switched to daily balancing of natural gas consumption. At the end of April 2019, LNZ Group received a license to supply natural gas in Ukraine and intends to occupy 50% of the market of natural gas consumers in agriculture [25].

The growing use and cost of petroleum fuels and natural gas, on the one hand, and their limited reserves, on the other, have led to intensive searches for new unconventional fuels (alcohols, methyl esters of plant oils, plant oils, biogas, etc.).

5. Conceptual provisions of the strategy of energy efficient and environmentally friendly development of rural areas

General principles, purpose, tasks of the Strategy.

Today, Ukraine has chosen a model of sustainable development, according to which all vectors of socio-economic development are aimed at a harmonious combination of a growing economy with minimal impact on the environment. However, a large number of both socio-economic and environmental issues remain unresolved.

The purpose of the Strategy is to solve current socio-environmental problems of Ukraine, as well as to implement the priority areas of sustainable development of rural areas, namely – energy efficiency and environmental security.

Strategy objectives include:

- determination of directions of waste management at the level of rural areas (communities), which will provide for their energy use to improve the environmental performance of territories and energy supply;

- development and substantiation of the technical and economic basis for the production and efficient processing of organic raw materials, as well as the efficient use of alternative fuels and renewable energy sources in the framework of energy autonomy of rural areas;

- development of energy cooperation in rural areas as a direction of ensuring energy security of rural areas.

Principles of Strategy development:

- hierarchy of waste management of agricultural enterprises, which provides actions for waste management in the following sequence: preparation for reuse; processing of waste in bioreactors with biogas production; use of recycled waste as biofertilizers;

- a precautionary measure stating that, if there is evidence of environmental risk, appropriate precautions should be taken;

- minimizing the impact of the strategy on the environment, which implies that companies will use biofuels as energy, which is more environmentally friendly;

- self-sufficiency, which provides for the creation of an integrated system for meeting the energy needs of rural areas, which will allow it to ensure independent production of energy resources and their consumption.

A brief overview of the problems of rural areas.

Table 5 summarized and specified the main problems of rural areas, as well as areas for their solution in the effective implementation of the model of sustainable development, which have already been studied and covered by domestic scientists.

The most pressing problems of rural development include the organization of rational nature management, energy consumption with minimal negative impact on the environment, careful use of energy resources with reasonable and sufficient satisfaction of technological and household needs of citizens in all types and forms of energy.

Strategic goals and ways to achieve them.

Strategic goal 1. Organization of processing of agricultural waste into biofuels: solid (briquettes, pellets) or biogas.

The attention to the issues of rational waste management in Ukraine by both the authorities and scientific circles has significantly increased in recent years. The solution to the problem is possible through the implementation of effective measures for rapid, safe recycling of waste and obtaining a

Comparison of the main problems of rural areas with the goals of sustainable development of rural areas

Modern problems of rural areas	Goals of sustainable development of rural areas
1	2
Lack of adapted education for sustainable development. Lack of motivation and social support for the formation of a modern specialist who is capable of active action, independent decision-making, flexible adaptation to changing conditions and needs of his rural area	Creation and implementation of regional policy, which provides for an effective system of government and administration in the center and in the regions, financial, economic and regulatory support based on the optimal combination of national, regional and local interests
Lack of an effective management system to ensure environmental quality and environmental management.	Reorientation of structural elements of the production potential of the territory and used resources to comply with environmental restrictions (reduction of external damage), development of resource-efficient production and consumption, organization of a stable monetary and financial system, cooperation in the world economic system. relevant institutions and infrastructure on the basis of harmonization of needs for growth and preservation of the environment, taking into account the interests of the parties regarding economic security
Tensions and deteriorating demographics; lack of quality and skilled labor; reduction of social infrastructure and, as a consequence, reduction of accessibility of social and cultural institutions; constant self-liquidation of rural settlements	Increasing the competitiveness of human capital and social development; limited sustainable economic growth based on innovation, taking into account the interests of future generations; environmental sustainability or minimization of environmental risks
Declining employment of the rural population, as a result of which many of the most able-bodied and skilled villagers work only on homesteads, run their own small-scale production or go to work in large cities or abroad.	Stable development of rural settlements and inter-rural areas in terms of increasing agricultural production, increasing the efficiency of agriculture, achieving full employment of the rural population and improving its living standards, rational land use
Wage arrears, unfavorable working conditions and non-compliance with safety, irregular working hours, non-compliance of jobs with sanitary and hygienic standards, lack of social guarantees	Growth, diversification and efficiency of the rural economy, stabilization of the population and increase in life expectancy, full and productive employment of the working population, improving the level and quality of life in rural areas, rational use and reproduction of their natural resource potential

Source: formed by author according to [26]

positive economic and environmental effect from the disposal and reuse of raw materials. Incineration and disposal are among the most commonly used methods of waste disposal in modern conditions. As combustion is a rather expensive and dangerous process for the environment, the use of biomass to generate heat and electricity is quite promising today. According to the Law of Ukraine “On Alternative Fuels” biomass is a “biodegradable substance of organic origin that undergoes biodegradation (waste from agriculture (crop and livestock), forestry and technologically related industries, as well as the organic part of industrial and household waste”.

At the same time, waste accumulation is increasing day by day with increasing population and consumption, which has a direct negative impact on the environment and the economy. Organic waste from agriculture poses a significant threat to the environment and the population [27]. Thus, the management of organic waste is very important given the growing demand for energy and the deteriorating environmental situation [28].

For the successful implementation of these documents, it is necessary to develop regional waste management plans in order to adapt national policies to the scale of regions and the needs of communities. A special place in the effective areas of waste management in the Strategy and National Plan is their use for energy production, as it is a way to energy-independent communities and reduce energy dependence of Ukraine. Agricultural waste and household waste have significant energy potential.

Of interest from the point of view of biofuel and energy production are wastes from both crop and livestock industries [29-31], taking into account the potential of agricultural enterprises and households, as they can be shared in the implementation of bioenergy projects at the community level.

Obtaining biogas from agricultural waste makes it possible to partially solve a number of problems facing the country’s agro-industrial complex: economic – increasing the competitiveness of agricultural products by reducing energy costs in its production; energy – own fuel production, ensuring energy independence of agricultural enterprises; agrochemical – obtaining environmentally friendly fertilizers; ecological – utilization of organic waste that harms the environment; financial – reducing the cost of disposal of organic waste and the purchase of traditional energy, social – creating new jobs.

The use of biogas for energy production displaces the use of fossil fuels and thus helps to reduce emissions of greenhouse gases and other pollutants.

Strategic goal 2. Creating efficient systems for the use of alternative energy sources in rural areas

Territorial communities, especially in rural areas, have significant prospects for the introduction of renewable energy technologies. After all, the development of RES leads to the creation of jobs at the local level and the involvement of both men and women in various professions, the development of social infrastructure [32].

The range of renewable energy sources that can be obtained and used in rural areas is quite wide [33].

– Solar energy. The global success of the solar industry is due to many factors. One of them is the leadership in the cost of electricity generated, which continues to improve endlessly. Another is universality: solar energy covers a wide range of electricity consumption at various levels – from very small housing systems to large enterprises, from individual stand-alone systems to integrated solar solutions in apartment buildings or agricultural greenhouses. There are also mobile photovoltaic systems and stand-alone solutions for rural electrification. More and more attention is paid to non-network systems – small photovoltaic installations, autonomous systems and mini-networks. These will also be GW-scale markets with double-digit growth rates in the coming years. Finally, no other power plant can be designed and built as quickly as any solar photovoltaic plant.

– Wind energy. Most wind farms under construction in Ukraine are mostly large and provide electricity to entire settlements. The capacity of the Overyanivsk wind power will be enough to provide electricity to 44,000 households, and the average capacity of new wind turbines commissioned in the first half of 2021 is 3.8 MW. But along with large wind farms also use small-generation wind turbines up to 10-20 kW. They can be used to provide electricity to small communities, making them energy independent.

– Bioenergy. In many countries around the world there is a real boom in fuel production from bioresources. There is also a growing interest in the use of non-traditional energy sources by government, business and academia, as well as by agricultural producers in Ukraine.

It is especially important to study the possibilities of using non-traditional and alternative energy sources in agriculture and in the agro-industrial complex as a whole, as such sources are available in Ukraine and

their use is still minimal (1-2% of the total energy balance). A special place in the structure of possible alternative sources of energy is occupied by biomass, the potential of which in Ukraine is quite large, but not yet fully understood, which forms a wide field for research in this area.

From the ecological point of view, bio-production in the agro-industrial complex will reduce greenhouse gas emissions, increase soil fertility and improve water quality, as well as contribute to the gradual revival of biodiversity. However, it is always necessary to compare the economic efficiency of energy and food use of agricultural products. It is obvious that the production of biofuels is not always an effective direction of its use, especially for countries that have problems with food security. Rising energy prices and growing demand for agricultural products from the food, feed and energy industries will determine the level of prices for energy products such as grain, oilseeds, sugar beet roots and related products – bard, meal, husks, molasses, pulp, etc.

This problem is quite difficult, because on the one hand, providing the population with food is a priority for every government, and on the other – the energy independence of the state is the basis of its sovereignty. Therefore, the analysis of the possibilities of growing bioresources for biofuels should be carried out taking into account the real situation with both the existing needs in the food sector and the available sources of traditional energy resources.

Establishing biofuel production in rural areas will significantly reduce their energy dependence and provide social infrastructure with cheaper energy resources.

Strategic goal 3. Development of energy cooperation in rural areas.

At the present stage, in conditions when the dynamics of rising prices for energy resources, in particular for household consumption, is not actually rising in relation to the income coverage of ordinary citizens, the peasants are the first stakeholders in energy cooperation. Therefore, every year the motivational potential in the realization of the potential of energy cooperatives grows, especially in the system of renewable sources [34].

Thus, the advantages of creating energy cooperatives are increased economic activity of citizens; creation of added value; ecological utilization of agricultural waste; attracting investments for rural development; creation of additional jobs; increase tax revenues in local budgets; increasing energy independence and ensuring energy autonomy of agricultural enterprises [30].

State support for the establishment of energy cooperatives and the adoption of best European and world experience in creating energy communities are important.

7. Conclusions

1. The energy efficiency of the economy is rational use of energy resources compared to other options for use or production of products of the same consumer level or environmental technical and economic indicators.

2. Energy supply of the enterprise is defined as the availability of all types of energy, which is necessary for the efficient operation of the enterprise. Types of energy in a broad sense, used by agricultural enterprises include: direct (fuel and energy resources), indirect (fertilizers, materials and raw materials); investment (machinery, equipment, maintenance and overhaul). At the same time, the process of efficient energy supply and rational energy consumption should be considered within the functioning of the energy management system of the enterprise.

3. The possible way of solving the problem of energy saving and efficient energy supply by implementing the energy management system is substantiated and the indicators of the internal component of energy security of the enterprise are determined.

4. It is proved that the agricultural sector is one of the main consumers of fuel and energy resources. It ranks second after industry in terms of their volume. With the declaration of independence in Ukraine, the use of fuel and energy resources of the agro-industrial complex has more than halved. This is due to: 1. reduction of sown areas, technological operations in crop production, truck fleet, livestock production; 2. the use of resource-saving technologies, as well as a more careful attitude to the use of energy resources. The volume of purchases of diesel fuel and gasoline in agriculture remains quite high, their cost is significant, due to annual price increases.

5. It is substantiated that the most adequate response to current threats in the energy sphere for Ukraine should be structural reforms in all areas of energy policy: energy efficiency, formation of competitive energy markets, diversification of energy supply, increasing the share of alternative energy sources and biofuel. Biogas technologies are of particular importance to provide agricultural enterprises with energy resources due to the high energy potential of this type of biofuel, as well as the available residues

of crop and livestock in agriculture (raw material base), favorable climatic conditions, relatively inexpensive labor.

6. The priority areas of modernization of the energy supply system in Ukraine include: diversification of the energy supply system; renewal and technical modernization of fixed assets of enterprises and their infrastructure; introduction and stimulation of rational use of fuel and energy resources; introduction of effective incentives to stimulate innovative development of existing at the local (regional) level as traditional (natural) minerals; and alternative (renewable) fuel and energy resources.

References:

1. Law of Ukraine “On Energy Conservation” № 74/94-VR of July 1, 1994. Retrieved from: <https://zakon.rada.gov.ua/laws/show/74/94-%D0%B2%D1%80#Text>

2. Tsapko-Piddubna O. I. (2009). Analiz mekhanizmiv realizatsii polityky enerhoefektyvnosti [Analysis of mechanisms for implementing energy efficiency policy]. *Naukovi visnyk NLTU Ukrainy – Scientific Bulletin of NLTU of Ukraine*, 19, 11, 300–311.

3. Bondar-Pidhurska O. V. (2012). Naukovo-metodychni pidkhody do otsinky enerhoefektyvnosti yak faktora konkurentospromozhnosti promyslovoi produktsii v innovatsiinii modeli rozvytku Ukrainy [Scientific and methodological approaches to assessing energy efficiency as a factor in the competitiveness of industrial products in the innovative model of development of Ukraine]. *Naukovi pratsi Kirovohradskoho natsionalnoho tekhnichnoho universytetu. Ekonomichni nauky – Scientific works of Kirovograd National Technical University. Economic sciences*, 22(2), 75–83.

4. Mitrakhovych M. M., Herasymchuk I. S., Sukhodolia O. M. (2003). Enerhoiennist VVP: tendentsii ta chynnyky vplyvu [Energy intensity of GDP: trends and factors of influence]. *Zbirnyk naukovykh prats NADU – Collection of scientific works of NADU*, 2, 140–149.

5. Mitrakhovych M. M., Herasymchuk I. S. (n.d.). Metodyka analizu enerhoefektyvnosti palyvno-enerhetychnoho kompleksu Ukrainy [Methods of energy efficiency analysis of the fuel and energy complex of Ukraine]. *www.nbu.gov.ua*. Retrieved from: www.nbu.gov.ua/portal/natural/nt/2009_1/Stati/5.pdf

6. Jewell J., Cherp A. (2012). The three perspectives on energy security: intellectual history, disciplinary roots and the potential for integration. *Current Opinion in Environmental Sustainability*, 3, 4, 202–212.

7. Minyailenko I. V., Poznyak Y. I. (2014). Enerhoefektyvnist vyrobnytstva ta yii rol u stvorenni konkurentospromozhnoi ekonomiky rehioniv Ukrainy [Energy efficiency of production and its role in creating a competitive economy of the regions of Ukraine]. *Efektivna ekonomika – Efficient economy*, 11. Retrieved from: <http://www.economy.nayka.com.ua/?op=1&z=3579>

8. Fedirets O. V., Yaremchuk M. O., Korsunskaya D. Ye. (2018). Enerhetychnyi menedzhment ta yoho znachennia v silskohospodarskykh pidpryiemstvakh [Energy management and its importance in agricultural enterprises]. *Ekonomichnyi forum – Economic Forum*, 4, 132–138.

9. Talavyriia M. P., Holub R. T. (2018). Enerhozberezhennia pidpryiemstv ahrarynoi sfery v Ukraini ta zarubizhnyi dosvid [Energy saving of agricultural enterprises in Ukraine and foreign experience]. *Naukovyi visnyk Natsionalnoho universytetu bioresursiv i pryrodokorystuvannia Ukrainy: zbirnyk naukovykh prats – Scientific Bulletin of the National University of Life and Environmental Sciences of Ukraine: a collection of scientific papers*, 290, 259–267.

10. Prakhovnyk A. V., Rozen V. P., Rozumovskyi O. V. (2018). *Enerhetychnyi menedzhment* [Energy management] (2nd ed., rev). Kyiv: Kyivska notna f-ka.

11. Dziadykevych Yu. V., Buriak M. V., Rozum R. I. (2010). *Enerhetychnyi menedzhment* [Energy management]. Ternopil: Ekonomichna dumka, 295 p.

12. Kaletnik G., Honcharuk I., Yemchuk T., Okhota Yu. (2020). The world in the regulation of the land circulation. *European Journal of Sustainable Development*, 9, 2, 557–568. DOI: <https://doi.org/10.14207/ejds.2020.v9n2p557>

13. Ishchenko S. V., Malysheva M. V. (2016). Metodichni pidkhody do otsinky efektyvnosti upravlinnia enerhozabezpechenniam pidpryiemstva [Methodical approaches to assessing the effectiveness of energy management of the enterprise]. *Efektivna ekonomika – Efficient economy*, 2. Retrieved from: <http://www.economy.nayka.com.ua/?op=1&z=4786>.

14. Hurniak I. H., Yurynets Z. V. (2015). Osoblyvosti formuvannia stratehii innovatsiinoho rozvytku enerhozberezhennia promyslovykh pidpryiemstv [Features of formation of strategy of innovative development of energy saving of industrial enterprises]. *Efektivna ekonomika – Efficient economy*, 2. Retrieved from: <http://www.economy.nayka.com.ua/?op=1&z=38>

15. Samborskyi V. O. (2014). Otsinka enerhetychnoi bezpeky pidpryiemstva yak skladova yoho stratehii enerhetychnoi bezpeky [Assessment of energy security of the enterprise as a component of its energy security strategy]. *Visnyk NTU “KhPI” – Bulletin of NTU “KhPI”*, 34, 166–171.

16. Maslak O. I., Hryshko N. Ye. (2019). Upravlinnia ekonomichnoiu bezpekoiu pidpryiemstva na zasadakh preventyvnoho rehuliuвання [Management of economic security of the enterprise on the basis of preventive regulation]. *Visnyk Kremenchutskoho natsionalnoho universytetu imeni Mykhaila Ostrohradskoho. Seriya “Ekonomichni nauky” – Bulletin of Kremenchug National University named after Mykhailo Ostrogradsky. Economic Sciences Series*, 1/2014/ (3), 44–51.

17. The Global Innovation Index. WIPO. www.wipo.int. Retrieved from: <https://www.wipo.int/publications/en/details.jsp?id=4330>

18. World Energy Outlook 2019. International Energy Agency. www.iea.org. Retrieved from: <http://www.iea.org>

19. Ukraine in cooperation with IRENA will attract the experience and investments of the world's leading countries in domestic renewable energy. State Energy Efficiency. Presentation, 2018. www.sae.gov.ua. Retrieved from: <http://www.sae.gov.ua/uk/news/2148>

20. Ofitsiynyi sait Derzhavnoi sluzhby statystyky Ukrainy [Official site of the State Statistics Service of Ukraine]. *ukrstat.gov.ua*. Retrieved from: <http://www.ukrstat.gov.ua/>

21. WEC Energy Trilemma Index Tool – World Energy Council. *trilemma.worldenergy.org*. Retrieved from: <https://trilemma.worldenergy.org/>

22. National plan to reduce emissions from large combustion plants. *mepr.gov.ua*. Retrieved from: http://mpe.kmu.gov.ua/minugol/control/uk/publish/article?art_id=245255506&cat_id=245255478

23. Directive 2012/27/EU on energy efficiency. Retrieved from: <http://enref.org/docs/dyrektyva-2012-27es-proenerhoefektyvnist>

24. Updated Forecast energy balance of Ukraine. Ministry of Defense of Dovkil and Natural Resources. April 29, 2020. *mepr.gov.ua*. Retrieved from: <https://mepr.gov.ua/news/35214.html>

25. LNZ Group will sell natural gas to farmers. *urkul.com*. Retrieved from: <https://kurkul.com/news/15561-lnz-group-prodavati-time-prirodny-gaz-agrariyam>

26. Termosa I. O. (2017). Sutnist staloho rozvytku ta yoho osoblyvosti v konteksti silskykh terytorii [The essence of sustainable development and its features in the context of rural areas]. *Prychornomorski ekonomichni studii – Black Sea Economic Studies*, 19, 33–37.

27. Tokarchuk D. M., Pryshliak N. V., Tokarchuk O. A., Mazur K. V. (2020). Technical and economic aspects of biogas production at a small agricultural enterprise with modeling of the optimal distribution of energy resources for profits maximization. *INMATEH – Agricultural Engineering*, 61(2), 339–349. DOI: <https://doi.org/10.35633/inmateh-61-36>

28. Kaletnik G., Honcharuk I., Okhota Yu. (2020). The Waste-Free Production Development for the Energy Autonomy Formation of Ukrainian Agricultural Enterprises. *Journal of Environmental Management and Tourism*, XI, 3(43), 513–522. DOI: [https://doi.org/10.14505/jemt.v11.3\(43\).02](https://doi.org/10.14505/jemt.v11.3(43).02)

29. Pryshliak N., Lutsiak V., Tokarchuk D., & Semchuk I. (2020). The Empirical Research of The Potential, Awareness and Current State of Agricultural Waste Use to Ensure Energy Autonomy of Agricultural Enterprises of Ukraine. *Journal of Environmental Management and Tourism*, 11(7), 1634–1648. DOI: [https://doi.org/10.14505/jemt.v11.7\(47\).04](https://doi.org/10.14505/jemt.v11.7(47).04)

30. Honcharuk I. V. (2020). Dosvid formuvannia enerhetychnoi avtonomii silskykh terytorii: otsinka roli kooperatyviv [Experience of Forming of Energy Autonomy in Rural Areas: Assessing the Role of Cooperatives]. *Ekonomika, finansy, menedzhment: aktualni pytannia nauky i praktyky – Economics, finance, management: topical issues of science and practice activity*, 1(51), 23–40. DOI: [10.32702/2306-6792.2020.19-20.38](https://doi.org/10.32702/2306-6792.2020.19-20.38)

31. Tokarchuk D. M. (2016). Stratehichni napriamy vyrobnytstva biopalyva silskohospodarskymy pidpriemstvamy Ukrainy [Strategic directions of biofuel production by agricultural enterprises of Ukraine]. *Ekonomika, finansy, menedzhment: aktualni pytannia nauky i praktyky – Economics, finance, management: topical issues of science and practice activity*, 7, 18–26.

32. Tokarchuk D. M. (2010). Metodichni osnovy otsiniuvannya sotsialnoi infrastruktury silskykh poselen [Methodical bases for assessing the social infrastructure of rural settlements]. *Evropejskaja nauka XXI veka* Sp. z o.o. «Nauka i studia», Polsha, Peremyshl, 8, 52–57.

33. Honcharuk I. V., Tomashuk I. V. (2019). Ekonomichna efektyvnist enerhetychnoi avtonomii APK za rakhunok vykorystannia biopalyv [Economic efficiency of energy autonomy of agro-industrial complex due to the use of biofuels]. *Ekonomika, finansy, menedzhment: aktualni pytannia nauky i praktyky – Economics, finance, management: topical issues of science and practice activity*, 2, 7–19.

34. Kaletnik H. M., Diuk A. A. (2020). Rozvytok kooperatsii v enerhetychnii sferi orhanizatsiino-ekonomichnoi sotsializatsii pryemnytskoho hospodarivannia na seli [Development of cooperation in the energy sphere of organizational and economic socialization of entrepreneurial management in rural areas]. *Ekonomika APK – Economics of agro-industrial complex*, 11, 19–29. DOI: <https://doi.org/10.32317/2221-1055.202011019>

**PROSPECTS FOR THE USE OF AGRICULTURAL WASTE
FOR BIOGAS TO RELIABLY PROVIDE
THE INDUSTRY WITH ENERGY RESOURCES**

Oleksiy Tokarchuk¹

DOI: <https://doi.org/10.30525/978-9934-26-193-0-10>

Abstract. The subject of research is theoretical and applied aspects of energy use of agricultural waste. General scientific methods of cognition and assessment of the objective nature of the transformation of economic phenomena and processes, instrumental and methodological apparatus of research in agriculture were used in the process of research: systematic approach – in learning the works of scientists; abstract-logical method – in determining the purpose and objectives of the study; analytical, statistical methods – in the study of; computational and constructive – improving the biogas reactor in order to increase the yield of biogas; strategic planning – compiling a strategy for efficient use of energy resources for enterprises with the help energy use of waste. The aim of the study is to investigate the use of agricultural waste for biogas to reliably provide the industry with energy resources. The results of the study showed that organic waste has the potential to be used as a raw material for biofuel production, namely biogas. Types of waste with significant bioenergy potential are identified, comparative energy indicators for traditional energy sources and biogas are shown, the concept of using biogas plants in agro-industrial production of Ukraine until 2030 is analyzed, the experience of countries in the organization of biogas production is shown and features of organizational and technological processes of biofuel production are considered. The Strategy for the efficient use of energy resources for agricultural enterprises of Ukraine is proposed and the biogas installation is improved to more efficient work.

¹ Candidate of Technical Sciences,
Associate Professor of the Department of Technological Processes and Equipment
of Processing and Food Production,
Vinnytsia National Agrarian University, Ukraine

1. Introduction

There is no doubt about the need to take into account the requirements of environmental protection in the formation of economic policy not only of the state but also of enterprises at the present stage of development.

The problems of waste management are at the forefront. They are complex, because they relate to various aspects – resource conservation, environmental security of mankind, ensuring competitiveness at the micro, macro, mega levels and more. At the same time, increasing the efficiency of their activities remains an important condition for enterprises.

Waste today is a concept from the natural, technical or geological sciences and an economic category. After all, waste is an integral part of production and interaction of the enterprise with the environment.

Waste is a powerful internal reserve to increase the efficiency and competitiveness of agricultural enterprises in domestic and international markets. Analysis of international practice shows that the development of a comprehensive system of waste management of agricultural production can not only increase the efficiency of material resources and efficiency of the enterprise as a whole, but also reduce anthropogenic pressure on the environment by returning waste as secondary raw materials. The energy direction of waste use as a raw material for biogas production deserves special attention.

The aim of the study is to define the best practice of energy use of agricultural waste to provide enterprises with energy resources.

This aim involves the following tasks:

- study of the role of alternative energy sources and biogas production in the energy supply of agricultural enterprises;
- definition of directions to increase the efficiency of fuel and energy resources use by the agricultural enterprises with an emphasis on production of biofuels;
- technical and organizational aspects of the organization of biogas production;
- improving the technical characteristics of biogas equipment in order to optimize the yield of biogas.

2. The role of biogas production in the energy supply of agricultural enterprises

The process of production in agricultural enterprises can be considered as a process of energy consumption due to the conversion of energy factors of production into agricultural products, which forms a specific energy environment of these entities. From a scientific and practical point of view, it is important to study various aspects of the formation of this environment, in particular the assessment of the place of bioenergy processes and their impact on energy efficiency of agricultural enterprises.

Scientists note that energy consumption in agricultural production is the process of using energy for production, services, work to meet the needs of enterprises and the population and obtain a certain economic effect [1].

Agricultural production has the main difference from others that the main means of production are land, plant and animal, forming complex biotechnical systems “man – plant – machine – environment” and “man – animal – machine – environment”.

The complexity of these systems is due to the presence of two biological subsystems, each of which is complex in itself, in contrast to technical systems used in industrial production. The energy component of these systems also differs significantly from technical systems in terms of energy origin. The most energy-intensive branch of agriculture is crop production, which consumes about 80% of energy resources of agriculture [2].

Therefore, the most adequate response to current threats in the energy sphere for Ukraine should be radical structural reforms in all areas of energy policy: energy efficiency, formation of competitive energy markets, diversification of energy supply, increasing the share of alternative energy sources and types of fuels.

A special place in alternative energy is occupied by the processing of biomass by methane fermentation to obtain biogas, which contains about 70% methane [3]. Utilization of biomass in agriculture is extremely important, where a large amount of fuel is used for various technological needs and the need for high-quality organic fertilizers is constantly growing. In turn, biomass provides one-seventh of the world's fuel, and ranks third in terms of energy, along with natural gas. In turn, this gas from organic biomass, regardless of origin, is a significant competition to traditional fuels due to the low cost of biomass [4].

Biogas is a generalized name for a combustible gas mixture obtained by the natural decomposition of substances of organic origin as a result of an anaerobic microbiological process, i.e. methane fermentation.

The technology of production of this gas is a biological process in which the decomposition of organic matter is carried out anaerobically, which means that the substrate will decompose without oxygen. Biogas consists mainly of methane, which is rich in energy, as well as carbon dioxide from residual gases, which include ammonia, hydrogen sulfide and water vapor. Fermentation residues can be used as organic fertilizers in the natural cycle of substances. The process of production of this gas helps to prevent the release of methane into the atmosphere, as well as to reduce the use of chemical fertilizers, reduces the risk of groundwater pollution. The most important thing for the economy of Ukraine is that the produced biogas is a by-product in the processing of organic waste [5].

Production waste is an unsuitable for the production of certain products types of raw materials, its residues that are not used, or substances that arise as a result of technological processes that are not subject to disposal in this production.

Waste is divided into primary and secondary. Primary is the waste generated directly during the harvest of agricultural crops (straw of cereals and other crops, stems, baskets of sunflower, waste from the production of corn). Secondary wastes are sunflower husks, buckwheat husks, rice, sugar beet pulp, etc.

A promising area for the use of agricultural waste is energy – the use as a raw material for biogas production. The range of organic wastes suitable for biogas production is quite wide.

– Agricultural waste. The concentration of wastewater impurities on livestock farms reaches 30,000-60,000 mg/liter. The amount of dry sludge is at least 20 million tons per year. Fermented sludge and manure after fermentation are usually neutralized and can be used as fertilizer. Estimates show that biogas production in rural areas can be considered profitable with 20 cows, 200 pigs or 3,500 hens. In agriculture, the substrates of biogas are crops: cereals, vegetables, potatoes, fruits and berries and other crops and plants, grain and molasses post-alcoholic bard, beer pellets, beet pulp.

– Livestock waste. 340 m³ of biogas can be obtained from 1 ton of dry manure as a result of anaerobic fermentation under optimal conditions.

During fermentation, the microflora develops in the manure, which consistently destroys organic matter to acids, and the latter under the action of syntrophic and methane-forming bacteria are converted into gaseous products – methane and carbon dioxide. At the same time, manure fermentation ensures its deodorization, deworming, destruction of the ability of weed seeds to germinate and transfer of fertilizers into the mineral form. It should be noted that the technology of obtaining biogas by anaerobic digestion in plants is the most economical way to process organic waste from poultry and livestock enterprises into dry fertilizer.

– Poultry waste. To determine the yield of biogas, we can assume that one typical poultry house contains 25 thousand hens, giving up to 5 tons of manure per day, from which 2500 m³ of biogas is obtained.

– Waste from distilleries – grain and molasses post-alcoholic bard.

– Dairy waste – lactose, whey.

– Biodiesel production waste – technical glycerin from rapeseed biodiesel production.

– Wastes from juice production – fruit pulp, berry, grape pomace.

– Waste fish and slaughterhouse – blood, fat, intestines.

– Wastes from potato processing, production of chips – cleaning, skins, rotten tubers.

– Sewage (aeration) gases are a product of fermentation of municipal sewage, which is a type of biogas containing 60-65% methane (CH₄), 30-35% carbon dioxide (CO₂) and 2-4% hydrogen). As practice shows, the output of sewage gases from the processing station, fed by the sewerage network, which serves a settlement with a population of 100 thousand people, reaches more than 2,500 m³ per day, which is equivalent to 2,000 liters of gasoline. Given that the population of large cities, as a rule, exceeds 500 thousand people, sewage gases are becoming a real source of alternative fuels.

– Sewage sludge from municipal sewage treatment plants. Depending on the chemical composition of sludge during fermentation, from 5 to 15 m³ of gas per 1 m³ of sewage sludge is released.

– Solid household waste. For the production of biogas from solid waste, the shredded waste in the plant is mixed with sewage sludge from septic tanks. The temperature of the mass rises to 65-70°C. The process of anaerobic fermentation takes 1-2 months. According to foreign experts, up

to 1.5 m³ of gas is emitted from 1 m³ of solid waste. The gases contain up to 50% methane, 25% carbon dioxide, up to 2% hydrogen and nitrogen. This technology is widely used abroad – in the US, Germany, Japan, Sweden.

Thus, almost all types of organic waste can be used as raw material for biogas production. First of all, it is agricultural waste (manure) and vegetable origin. Practice shows that industrial waste (sugar, alcohol, dairy, breweries), as well as municipal wastewater treatment plants are also used. Another possibility is the use of natural anaerobic fermentation processes on the example of solid waste from landfills and dumps [1].

To calculate the yield of biogas from a particular raw material, it is necessary to conduct laboratory tests or look at reference data and determine the content of fats, proteins and carbohydrates. In determining the latter, it is important to know the percentage of rapidly degradable (fructose, sugar, sucrose, starch) and hardly degradable substances (e.g. cellulose, hemicellulose, lignin). Having determined the content of substances, you can calculate the gas yield for each substance separately and then add up. In addition to waste, biogas can be produced from specially grown energy crops, such as silage corn or selfies, as well as algae. Gas output can reach up to 500 m³ per 1 ton.

Biogas production is growing rapidly in the world and its use in energy is expanding [6; 7].

The EU biogas sector is very diverse, depending on national priorities, financial incentives and relevant raw materials. In particular, Germany and the United Kingdom are the largest producers of biogas in the EU. Germany produces 93% of biogas by fermentation technology, mainly corn silage. The United Kingdom, Estonia, Greece, Ireland, Portugal and Spain produce more than 80% of biogas in landfills. In other countries, combinations of different types of technologies and raw materials are used.

Germany became the leader in the production of biogas from agricultural waste in 2020, the country produces 64% of the total amount of biogas in the EU. Italy, the Czech Republic and the United Kingdom account for 13%, 5% and 4% respectively. Today, there are more than 11,000 biogas plants in Germany with a capacity of 500 kWh to 2 MWh.

The spatial aspect of the use of livestock waste for biogas production in world practice is expressed in 2 development strategies: German and Danish.

The first is characterized by the use of livestock waste in the places of their formation or accumulation (for the needs of the same farms in which this waste will be generated), the second – the creation of centralized bioenergy plants that consume waste from several farms.

The German model is characterized by large specific investments, so it is effective only in the case of stimulating the development of bioenergy by the state, which is typical for Germany and Austria, or in favorable climatic conditions, when there is no need for methane tanks of complex design (Italy).

The Danish model is characterized by three fundamental advantages over the German one: a reduction in specific investment due to an increase in unit capacity; possibility of cogeneration (production of both heat and electricity at the same time); possibility of co-fermentation (the effect of a significant increase in the specific yield of biogas due to the simultaneous use of several types of bioresources in the methane tank) [6].

Of the six largest European companies in the biogas industry three are German: Strabag Umweltsanierungs GmbH, Schnack Biogas AG, Biotechnische Abfallverwertung – with a total of 280 plants. There are more than 110,000 anaerobic fermentation plants in Germany today, of which about 4,000 are large and about 7,000 are medium. In the future, 10-20% of the country's natural gas could be replaced by biogas. According to forecasts, the number of installations in Germany by 2025 will reach 20 thousand units.

Denmark is the leader in terms of biogas intensity, where this type of fuel provides almost 20% of the country's energy consumption. Lemvig Biogas Company has the largest biogas plant in Denmark. Waste from approximately 75 farms, as well as residual industrial products, are used to generate heat and energy. More than 21 million kWh of energy are generated annually from biogas produced [1].

The biogas market in the United States is developing much more slowly than in Europe. As of January 2019, there were about 252 biogas plants operating on commercial livestock farms. Most of these facilities use biogas to generate electricity. Several farms use biogas to produce transportation fuels, including Hilarides Dairy in California and Fair Oaks Dairy in Indiana.

Since 2002, the Chinese government has allocated about \$200 million annually to support the construction of biogas plants. The subsidy for each

installation is approximately 50% of the average cost. Thus, the government has achieved an annual increase in the number of biogas plants to 1 million per year. In total, there are already more than 30 million farms in China, 3.7 million in India and 200,000 in Nepal using biogas. Today, China's rural areas produce about 16 billion m³ of biogas, which is used as a household fuel by more than 50 million people.

The development of the biogas market in Ukraine is expected to replace 2.6-18 billion cubic meters of natural gas per year, will strengthen the country's energy security, create new jobs, economic development of regions, cover peak loads in the grid, dispose of crop and livestock waste, as well as some food waste. The introduction of biogas projects in Ukraine was launched by the introduction in April 2013 of a "green" tariff (GT) for biogas. However, the corresponding tariff is low and provides for further reduction [8].

The Law of Ukraine "On Amendments to Certain Laws of Ukraine to Ensure Competitive Conditions of Electricity Production Using Alternative Energy Sources" (2015) amended the Laws of Ukraine "On Alternative Fuels" and "On Principles of Functioning of the Electricity Market of Ukraine". It provides GT for electricity produced from biomass (at the level of 12.39 eurocents / kWh), as well as a surcharge to GT for businesses that use Ukrainian components in the construction of energy generating facilities.

The use of biomass and biogas in Ukraine has significant potential for heat and electricity production.

The concept of using biogas plants in agro-industrial production until 2030 (Table 1) provides that given the technical and economic feasibility and current structure and size of agro-industrial enterprises in Ukraine, the market for biogas plants is estimated at about 1,600 mini-CHP plants with a capacity of 100 kW.

The total installed capacity of biogas installations (BGI) can reach 820 MW for electric and 1100 MW for thermal. By 2030, it is necessary to master, respectively, 50% of the economically viable market for biogas plants.

At the same time, the total annual electricity production in 2030 should be 2.5 billion kWh. In general, about two-thirds of biogas will be produced from corn silage and the rest from waste.

**The concept of using biogas plants
in agro-industrial production until 2030**

Number of installations	Total biogas production	Total power	Total thermal capacity	Annual electricity production, net	Annual production of thermal energy	Reduction of greenhouse gas emissions	Investments	Job creation	Areas for corn
units	million m ³ per year	MW of current	MW of heat	million kW / hours	million Gcal	million Gcal	million UAH	units	thousand hectares
2020									
143	290	74	97	0.45	0.4	1.2	2645	920	27
2030									
811	1655	420	550	2.5	2235	6.0	14970	5190	155

Source: [9]

A total of about two thirds of biogas will be produced from corn silage, and another third – from waste. 0.15 million hectares of arable land will be needed to grow the required amount of corn silage – 0.5% of its total area in 2020.

The potential for heat use from mini-thermal power plants will be 2.234 million Gcal in 2030. 5,200 jobs will be created by 2030 and greenhouse gas emissions will be reduced by 6 million tons per year [10].

The biogas sector in Ukraine has tended to grow steadily in the last few years. This was partly due to the expected reduction of the “green” tariff for electricity from biogas from January 1, 2020 by 10%. Companies that planned to build a business in this area sought to complete by this date. But the efforts of the Bioenergy Association in particular have extended the “green” tariff for biogas at the same level until 2030.

Projects with “cheap” raw materials, such as manure and sugar beet pulp, have developed well. Today there is progress in biogas, but the growth dynamics of the industry does not coincide with the National Plan

for Renewable Energy Development in Ukraine until 2020. RES in general, and biogas in particular, do not feel very comfortable today due to problems with the solvency of SE “Guaranteed Buyer” (a specially created structure for guaranteed redemption of “green” electricity at a “green” tariff).

Biogas projects depend on raw materials, so the inflow of funds should be constant for the stability of operation.

Generating energy from the sun and wind is a little easier – you don’t have to buy a natural energy source. There are also alarming signals from the authorities about a possible radical revision of the current rules in the RES market, which will affect the biogas business accordingly. These factors do not motivate new potential investors to invest in such projects. And if businesses that have solar and wind power plants can “survive” the reduction of the “green” tariff due to the zero cost of “raw materials” and the constant reduction in technology, then biomass and biogas – no. Even the current “green” tariff does not allow in most projects to achieve an attractive return on investment in 4-5 years (typically at least in 6-7 years).

Given the problems in the management of complex biogas technologies, a number of projects at the current rate of “green” tariff may not pay off at all. The entry of biogas projects into the new market of “green” auctions is potentially interesting for such business, provided that the difference between the current “green” tariff and the tariff on the results of the auction will not exceed 10%. Therefore, any drastic changes to stimulate the generation of energy from biogas in the direction of reduction, may stop the development of the industry.

The forecast for today indicates that under the current system of incentives, the biogas sector of Ukraine will develop at a rather limited pace by inertia for another 3-5 years, mainly through large-scale projects on cheap raw materials. New prospects may open up with the introduction of the biomethane market in Ukraine. Much depends on the political will, the strategic course of the state. It is necessary to think what will happen after 2030, when the Law on Ensuring Competitive Conditions for the Production of Electricity from Alternative Energy Sources expires.

Of particular importance are biogas technologies to provide agricultural enterprises with energy resources.

According to the Law of Ukraine № 287-VIII “On animal by-products not intended for human consumption” [11], the disposal of animal waste

in Ukraine is carried out exclusively by specialized companies and can not be performed by companies producing animal products intended for human consumption. Manure and animal residues belong to the second class of waste and can be converted into organic fertilizer after mandatory sterilization under pressure or into biogas by sterilization under pressure.

Processing facilities for animal waste must be located separately from food companies. Waste disposal companies are market operators, and those market operators who dispose of or remove by-products without pressure sterilization or without processing into biogas under pressure after sterilization should be fined. For legal entities the fine is 23-30 minimum wages, for private entrepreneurs – 8-15 minimum wages. Sometimes companies prefer to pay a fine and not take further action to dispose of livestock waste. However, large agribusinesses are subject to inspections by the Ministry of Health, the Prosecutor’s Office, the Sanitary and Epidemiological Service and the Environmental Inspectorate of the Ministry of Environmental Protection and Natural Resources. Therefore, in some cases, biogas plants using Ukrainian equipment are economically feasible even to cover the costs of waste disposal.

Comparative energy indicators for traditional energy sources and biogas are shown in Table 2.

Table 2

**Comparative energy indicators
for traditional energy sources and biogas**

Product	Units of measurement	The equivalent of 1 m³ of crude biogas 23 MJ/m³	The equivalent of 1 m³ of purified biogas 35 MJ/m³
Electricity	kWh	0,63	0,95
Natural gas	m ³	0,62	0,94
Coal	kg	0,83	1,26

Source: [12]

The most effective are bioreactors of biogas plants that operate in thermophilic mode with a temperature of 43-62°C. Such plants with three-day fermentation of manure produce 4.5 m³ of biogas per liter of useful reactor volume.

In turn, the use of biogas makes it possible to obtain heat and electricity, which is necessary for farms. In the case of mass use of biogas technologies in rural areas, significant savings in fossil fuels can be ensured.

In addition to the actual biogas, the biogas installation makes it possible to obtain organic fertilizers [13; 14].

Mineral fertilizers are expensive and more concentrated. Compared to organic, they are more difficult to digest. Organic fertilization improves soil structure. Macronutrients of this natural fertilizer saturate the soil with almost the full set of necessary substances, increasing the percentage of humus. Namely, the fertilizer is found in the soil in forms accessible to plants.

For example, 350 tons of fertilizer per 1 ha increase the content of potassium and phosphorus by 10 mg/kg. While the average potassium content in the soil is 80 mg/kg. This means that you can annually increase the content of only the main macronutrients by 10 mg/kg. And, as a result, raise the level of ash elements in the soil from medium to high level.

3. Strategic directions for improving the efficiency of fuel and energy resources use and organization of biogas production

The purpose of strategic planning in the field of efficient use of energy resources by agricultural enterprises is to establish an algorithm for forming a base of energy resources (traditional and alternative) and their economical use to reduce energy intensity of products. Ultimately, this is necessary to ensure the competitiveness of agricultural enterprises in the long run. Insufficient development of concepts, strategies and models of development has a negative impact on agriculture, which is not competitive enough in world markets.

We propose the implementation of the Strategy for the efficient use of energy resources for agricultural enterprises of Ukraine, which will guarantee a reduction in energy intensity of products and increase its competitiveness. The main areas of implementation of the Strategy will include:

1. Introduction of energy saving technologies.
2. Introduction of energy management.
3. Use of alternative fuel and energy resources.

1. Introduction of energy saving technologies. An important role in the efficient use of fuel and energy resources is played by organizational

and technological support of the production process, the use of energy-saving equipment and technologies. Tractor and combine fleet of agricultural enterprises of Ukraine is 50-70% older than 10 years. This leads to constant huge costs for spare parts, overspending on fuel and lubricants, a high percentage of breakdowns, more than 15% of crop losses. The optimal equipment of the machine-tractor fleet of farms with modern equipment (both domestic and foreign) with their rational use allows to reduce fuel consumption by 10-40% in some technological operations.

More significant reserves are in modern technologies (minimum and zero tillage, track technology, etc.). Their implementation reduces fuel consumption by up to 70%. This is evidenced by both foreign and domestic experience.

The comparative efficiency of the use of resource-saving technologies in comparison with the classical one is given in Table 3.

Table 3

Efficiency of application of resource-saving machinery and technologies in the conditions of Ukraine in comparison with classical technology, %

Technology	Reduce the use or cost of motor fuel	The share of fuel in the cost of production	Energy intensity of products	The cost of production
Machinery				
Combined units	22	85	69	86
Gas cylinder machinery	37	66	100	93
Technologies				
Precision farming	20	84	70	84
Minimum tillage	65	31	40	83
Track technology	18	92	73	82

Source: [15]

Tillage by traditional methods is the most expensive. This technology in recent years has led to a decrease in humus, to soil degradation. World trends point the way to frugal agriculture. More than 124 million hectares of land in the world have been transferred to these technologies. 7 million hectares are added annually. This is proof of the viability and sustainability

of technology. Reducing the mechanical impact on the soil and increasing the content of organic matter due to the constant preservation of plant residues can stop soil degradation.

Savings technologies do not reduce grain yields, but fuel consumption in tillage is reduced by 1 liter while reducing tillage depth by 1 cm. Comparison of plowing and direct seeding technologies indicates savings of fuel and lubricants by 2.5 times by reducing field and use of equipment for less energy-intensive technological operations.

One of the measures to increase energy efficiency and energy saving is the creation of innovative farms – a model of environmentally and economically efficient production with a concentration of modern energy and resource-saving technologies. Such technologies include: mulching crops, direct sowing, efficient irrigation. Precision farming technologies are used: navigation equipment system, field travel system, Controlled Traffic Farming, differential fertilizer application system and plant protection products.

The introduction of energy efficient technologies is impossible without incentives from the state. This regulation is carried out through the use of both administrative and economic methods. In the period of economic recession that Ukraine is currently experiencing, it is necessary to use mainly policy regulators. In the transition to the development phase, economic regulators should dominate [16].

Methods of state regulation should not be opposed. It is advisable to apply them depending on the specific economic situation. At the same time, the state must create common transparent “rules of the game” and guarantee their observance by all economic entities.

In order to carry out applied research and develop new models of equipment and technologies, the creation of technology parks may be justified. To revive the production of complex agricultural machinery (tractors, internal combustion engines and combines), it is advisable to use free or special economic zones with appropriate preferential taxation (zero VAT rate, customs tax on imported components, etc.). According to the experience of the domestic automotive industry, the implementation of this mechanism since 2000 has brought the production of cars and buses on the path of sustainable growth, and budgets at all levels have received more revenue due to multiple increases in production.

Improving the efficiency of energy resources should be stimulated by environmental regulation. The fact is that reducing exhaust emissions requires the use of energy-saving technologies and cost-effective machinery.

It is important to use the subsidy mechanism, which is used to cover part of the costs for the development and implementation of the latest energy-saving technologies and equipment. Together with loans for energy efficient equipment, they have an investment form. Many countries of the European Union use such a policy. Thus, in Germany, 50% of the cost of diesel biofuel plants is compensated at the expense of state funding.

Implementation of the state policy to support the use of biofuels and energy-saving technologies by regulatory methods in market conditions is impossible without the widespread use of economic incentives. Highly developed countries (EU, USA, Japan, etc.) have extensive experience in this area.

At the first stage, they applied the following economic incentives:

- loans at low bank rates;
- sale of energy saving equipment without indirect taxation;
- tax benefits for the production and use of alternative fuels of plant origin;
- accelerated depreciation of machinery and equipment;
- subsidies (direct and indirect) to cover the production costs of enterprises;
- investments.

It is necessary to inform agricultural producers about modern energy-saving technologies, implement pilot projects and constantly monitor the efficiency of energy resources at the state level.

2. Energy management. The problem of energy saving and efficient energy supply can be solved only by implementing an energy management system.

The company's energy management system (EMS) is a set of organizational, technical and software tools that together manage the production process in such a way that only the minimum required amount of fuel and energy resources for the production of a certain number of products or services.

In order to ensure the efficient use of energy in enterprises, an energy management service is created, headed by the energy manager of the enterprise.

His function is to manage the operation of the service and ensure the achievement of the planned energy saving effects. He is responsible for energy managers in various areas of energy conservation (heat supply, electricity, water supply, compressed air supply), whose responsibilities include: control and planning of energy consumption, energy management cycle in energy conservation, development and implementation of measures for generation, distribution, use types of energy.

Energy managers of shops and sections with an annual energy budget of UAH 10 million and more are also subordinated to the energy manager of the enterprise. They control and plan energy consumption in shops and polling stations, organize the elimination of energy losses and implement energy saving measures for all types of energy consumed by equipment in sections.

The Energy Management Service is also a link between businesses and various inspectorates that oversee the efficient use of energy resources. For small agricultural enterprises, we offer the introduction of the position of energy manager only.

The energy manager belongs to the administration of the enterprise (organization), but he does not manage people, but controls energy consumption. The position of energy manager refers to the middle manager with direct subordination to the director or chief engineer of the enterprise (organization).

The energy manager must be able to:

- compile tables of energy consumption at the enterprise (organization), by divisions and equipment and fuel and energy balance of the enterprise (organization);
- analyze energy consumption taking into account the assessment of energy saving measures and prepare proposals for improving the production process;
- determine the efficiency of energy consumers and control the investment of energy saving measures;
- provide consulting services on energy saving at the enterprise;
- conduct an internal energy audit and know the butterfly of energy management assessment at the enterprise and the encouragement of employees of the enterprise who save energy;
- develop proposals to attract staff to save energy;

- check and evaluate energy bills and contracts related to energy consumption;
- analyze energy flows in detail and determine and constantly monitor specific energy consumption rates;
- calculate investments, operating costs and analyze the possibilities of subsidies and their practical use;
- submit proposals to the administration regarding the new investment policy;
- manage staff.

The energy manager must meet the following requirements:

- have basic knowledge of energy management and an idea of the basic technologies used in the enterprise (organization);
- be able to work with new information technologies, analyze data on energy consumption, conduct economic analysis of energy saving measures and develop these measures and conduct internal audit of the enterprise;
- have broad and original views on energy saving and be proactive and persistent in solving problems related to energy conservation;
- be able to communicate with both the administration and the staff of the enterprise.

3. Use of alternative fuel and energy resources. Today, the use of non-traditional and alternative energy sources in agriculture and in the agro-industrial complex as a whole is especially relevant, as such sources are available in Ukraine and their use is still minimal (6.6% of the country's total energy balance in 2020).

Biomass occupies a special place in the structure of possible alternative energy sources, the potential of which in Ukraine is quite large, but not yet fully studied [17].

From the ecological point of view, bio-production in the agro-industrial complex will reduce greenhouse gas emissions, increase soil fertility and improve water quality, as well as contribute to the gradual revival of biodiversity [18]. However, it is always necessary to compare the economic efficiency of energy and food use of agricultural products.

This problem is quite difficult, because on the one hand, providing the population with food is a priority for every government, and on the other – the energy independence of the state is the basis of its sovereignty. Therefore, the analysis of the possibilities of growing bioresources for

biofuels should be carried out taking into account the real situation with both the existing needs in the food sector and the available sources of traditional energy resources.

It is expected that the energy use of all types of biomass of Ukraine will be able to provide an annual replacement of 9.2 million tons of conventional fuel (c.f.) fossil fuels at the level of 2030, including due to energy use of crop residues, in particular: straw – 2.9 million tons of c.f., firewood and wood waste – 1.6 million tons of c.f., peat – 0.6 million tons of c.f., solid waste – 1.1 million tons of c.f., production and use of biogas – 1.3 million tons of c.f., fuel ethanol production and biodiesel – 1.8 million tons of c.f., firewood and wood waste – 1.6 million tons of c.f., peat – 0.6 million tons of c.f., solid waste – 1.1 million tons of c.f., production and use of biogas – 1.3 million tons of c.f., fuel ethanol production and biodiesel – 1.8 million tons of c.f.

One of the important ways to increase the efficiency of energy supply of enterprises, especially enterprises of the agro-industrial complex, is the ability to provide electricity and heat to the most important areas of production, which requires backup energy sources and backup (autonomous) energy supply systems.

Despite some changes, the development of alternative energy in Ukraine is slow due to the low level of technical re-equipment of production; low intensity of use of renewable energy resources available at the local (regional level).

4. Technical and organizational aspects of the organization of biogas production

Central Ukraine has a strong potential for alternative energy development through the use of agricultural waste (straw, corn stalks, sunflower husks, biological livestock waste), but underestimating the potential for alternative energy production preserves the solution of Ukraine's energy problem. The lack of effective mechanisms of economic stimulation and financial responsibility for the rational use and economical use of fuel and energy resources of economic entities of all forms of ownership does not contribute to reducing the level of energy dependence of the Ukrainian economy.

The development of alternative energy in Ukraine will allow to make real structural changes: to reduce energy consumption, to increase

energy efficiency and energy savings; modernize the energy sector and energy supply; to implement in practice the principles of sustainable (environmentally oriented) type of economic growth; to deprive the national economy of traditional energy dependence and to increase the competitiveness of national production, to provide social infrastructure with energy resources [19; 20].

Modern agriculture and biogas technologies in modern agriculture stand side by side as two inseparable components [21]. The process has gone so far that, for example, the EU no longer even keeps track of the total number of biogas plants – the technology has become so common and widespread that there is simply no need to calculate biogas capacity.

But the situation in the Ukrainian agricultural sector is a paradox. In general, domestic agricultural enterprises are leading in the introduction of new technologies, and this fact is recognized by both foreign and domestic experts. But this does not apply to the use of bioenergy in general, and especially the problem of agricultural enterprises using biogas installations.

Biogas plants have numerous advantages over fossil fuels and other types of RES:

- the combination of waste from seasonally operating enterprises (for example, sugar factories) with farm waste allows to produce energy throughout the year;
- creation of new jobs or new income opportunities during the year for workers employed in sugar factories, which are located mainly in small towns in Ukraine and are often the main employer of the city;
- disposal of a very wide range of agricultural residues;
- production of organic fertilizers that can be used for organic farming (another way to increase the competitiveness of agriculture in Ukraine);
- modern management of agricultural waste management, especially manure (which helps reduce odor, restore soil, preserve potential agricultural land that could be used for settling tanks);
- the possibility of energy production near the places of origin of agricultural waste (which does not require transportation of fuel over long distances);
- the possibility of covering the peak load in the network and failures of power generation created by intermittent RES;

– gradual transition to a model of decentralized energy supply for local communities;

– increase the use of biogas obtained from sugar production and agricultural waste.

Livestock waste mixes well with any other substrates, as this raw material contributes to the stability of fermentation processes in biogas production. And the addition of corn silage or other substrates increases the overall yield of biogas.

Silage has been used in biogas production for many years in the world. The ancestor is Germany, which introduced a higher tariff for energy derived from biogas. There began to build stations whose total capacity exceeded the capacity of four nuclear units. Of course, there was not enough waste, so they began to use raw materials in a ratio of 30 to 70 – manure and silage. About 1 million hectares of land, equal to 10% of Germany's total land area, were used for silage cultivation. When asked by farmers, seed companies even began to develop special hybrids of plants that behaved best in reactors.

The introduction of technology in Ukraine was delayed due to legislation. Initially (in 2009) the law on bioenergy did not provide for a “green”, i.e. increased tariff, for projects that work with biomass – only water, sun and wind. Then (since 2013), when biomass was included in the legally approved list of sources for bioenergy, silage and grass were deleted from it. It was written that biomass is organic waste from agriculture and forestry. The key word is “waste”. This means that silage or firewood are no longer suitable as raw materials, because they are not waste. The EU says that biomass is waste, residues and agricultural and forestry products. After all, silage is a product, and straw is a residue. All this was corrected only in July 2015.

The production process of biogas can be described as pre-treatment and fermentation of raw materials (cattle farm effluents with a moisture content of 95%, sheep manure and corn silage) under anaerobic conditions, as well as the use of the manufactured product – biogas.

At the first stage of fermentation (hydrolysis stage) the process of biochemical cleavage of macromolecular compounds (carbohydrates, fats, proteins) into low molecular weight takes place.

At the second stage, with the participation of acid-forming bacteria, the further decomposition of substrate takes place, with the appearance of organic acids and salts, as well as alcohols, CO₂ and H₂, and then H₂S, NH₃,

The final result of anaerobic fermentation is obtained at the third stage of the process – methane fermentation, in which the main role is played by methane-forming microorganisms.

Biogas installations are actively used in farms in Ukraine and in the world nowadays. The disadvantage of most installations is the lack of biomass heater, and due to insufficient and uneven heating of the mixture, there are significant temperature fluctuations in the volume, which violates the technological requirements of anaerobic fermentation.

Known biogas installation [22], which contains a tank covered with insulation, a consumer pipe with a tap, a vertical propeller stirrer on a hollow shaft, a loading hopper with a first slide latch over it and a protective gas distribution grille. There is a hole for the removal of spent biomass substrate under a vertical propeller stirrer with a second gate valve in the lower part of the installation. The tank is wrapped with an electric heating cable with a thermostat, there are two heat exchange circuits, each of which consists of heat exchangers, the first heat exchanger is connected to the gas pipeline, compressor and biomass substrate preparation unit, and the second to the spent biomass substrate pipeline for biomass substrate preparation. The disadvantage of this biogas plant is the low efficiency associated with insufficient mixing and heating of the biomass substrate.

The study is based on the problem of improving the biogas reactor by increasing the efficiency of maintaining the heating temperature of the substrate and its uniform mixing to intensify the process of anaerobic fermentation. The problem is solved by the fact that the biogas reactor with uniform mixing and heating contains the reactor vessel, thermal insulation layer, unloading auger with electric drive, and differs that it is additionally equipped with a cylindrical tubular heater, with cleaning clamps on the turns of it. The heating element is made in the form of a cylindrical tubular spring, on the turns of which there are cleaning clamps, the rotational movement of which is transmitted from the rope system through the pulley, insert and offset pins.

Figure 1 shows a schematic of a biogas reactor with uniform stirring and heating.

The biogas reactor contains a loading neck 1, reactor housing 2, insulating layer 3, unloading auger 4 with electric drive 5, cylindrical tubular heater 6, on the turns of which are fixed three clamps 7, which rotate clean the surface of the heater turns, providing efficient heat dissipation. The clamps 7 through

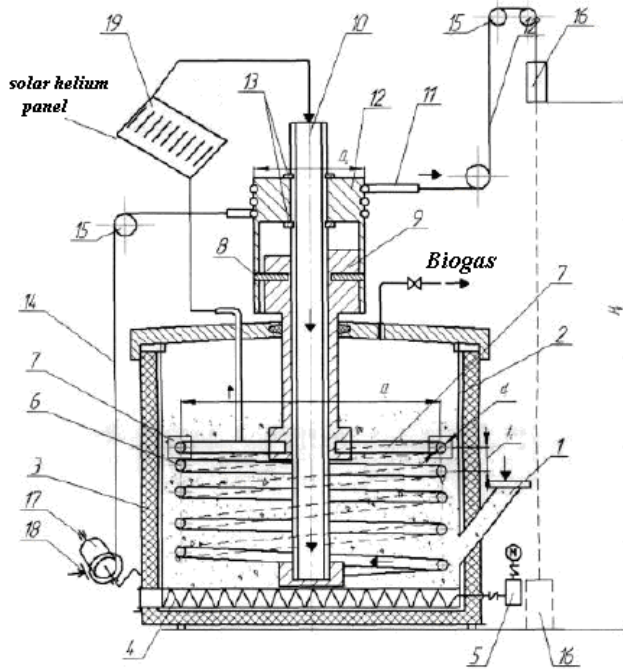

Figure 1. Biogas reactor with uniform stirring and heating

Source: author's patent [23]

the pins 8 are fixed to the insert 9, which can be moved on the Central pipe 10, and rotated by pins 11 from the pulley 12. Axial displacement of the pulley fix locking rings 13. Pulley 12 wraps the cable 14 to which through the guide blocks 15 suspended load 16, the lifting of which is carried out by a lifting mechanism 17, the braking of which is carried out by the latch 18. To heat the substrate solar helium panel 19 is used.

The biogas reactor works this way. The load 16 rises to a height H_0 by means of the lifting mechanism 17, while the cable 14, passing through the guide blocks 15, wraps the pulley 12 in several turns, at this time the lifting mechanism is braked by the clamp 18.

To carry out uniform mixing release the clamp 18 gravitational forces are lowered, while the cable 14 rotates the pulley 12, which transmits torque

through the pins 11 to the insert 9, which rotates on the central tube 10, which moves the coolant from the solar helium panel 19 to the cylindrical tubular heater 6, which gives heat to the substrate, which is located inside the reactor vessel 2. To unload the spent substrate, the unloading auger 4 is pre-actuated by means of an electric drive 5 located in the lower part of the biogas reactor.

Thus, the use of a cleaning device for the heating element of the biogas reactor makes it possible to increase the efficiency of heat transfer and ensure uniform release of biogas. Uniform mixing and heating of the substrate in an isolated reactor increases the energy efficiency of the bioreactor.

Another product provided by a biogas plant is biofertilizers, which make a significant contribution to the revenue side of biogas projects [24].

Biofertilizer is a product of fermentation of organic matter under anaerobic conditions (without air access). Biofertilizer, as a product of biogas technology for processing cattle manure, pig manure and other organic agricultural waste, contains all the necessary components of fertilizers (nitrogen, phosphorus, potassium, macro- and micronutrients) in dissolved, balanced form in the proportions required for plants, as well as active biological growth stimulants, significantly increase yields.

Biofertilizer, as the end product of the biogas plant completely replaces mineral fertilizer, as it contains all the necessary components of fertilizers: nitrogen-phosphorus-potassium, macro-and micronutrients in dissolved balanced form in the ratios needed for plants, as well as active growth stimulants.

Comparison of different types of fertilizers (biofertilizers, mineral and organic fertilizers) by quality indicators is presented in Table 4.

Based on the data in the Table 8, we can see that biofertilizers are better absorbed by plants, do not have pathogenic microflora and weed seeds, have a useful microflora in large quantities, there is no adaptation period when using them.

Biofertilizers act on the plant immediately after their introduction into the soil. They are used as a year-round fertilizer for all agricultural, ornamental and domestic crops diluted with water, by injection, surface watering or spraying the leaf surface of plants. Having a slightly alkaline environment (pH 7.6-8.2), they reduce soil acidity. They are used in all climatic zones, for all types of soils, increasing their fertility and improving their ecological condition.

Comparison of biofertilizers with other types of fertilizers on qualitative indicators

Indicator	Biofertilizers	Mineral fertilizers	Organic fertilizers (manure)
Assimilation by plants, %	100	35-40	80
Nitrogen losses, %	5-8	50	30
Nitrate content in products	no	yes	no
Leaching from the soil, %	15	50	80
The presence of pathogenic microflora	no	no	yes
Presence of weed seeds	no	no	yes
The presence of beneficial microflora	yes in large quantities	no	yes in small quantities
Adaptation period	no	yes	yes

Source: formed by the author according to [25]

Biofertilizers increase the resistance of plants to adverse environmental influences, especially during late frosts, microbiological processes in the root zone of the plant occur with the release of heat needed to protect shoots. The application of biofertilizer improves the survival of newly planted fruit crops, both in spring and autumn.

Biofertilizers are widely used in the Netherlands, Germany, England, Finland, Italy, China, India and other countries. Especially good results of fertilizers are given in Ukraine in the cultivation of potatoes, beets, cabbage, carrots, tomatoes, cucumbers, strawberries, raspberries, currants and other vegetables and berries, as well as cereals, fodder and lawn grasses, ornamental flowers such as roses, daffodils, peonies, etc.

The choice of equipment for biogas production in Ukraine is not so wide, obviously given that this business is still in its infancy.

The most famous world brands are German. These are Schmack, EnviTec Biogas, Biogas Nord, Lipp. The most expensive equipment is produced by Schmack: the cost of a turnkey biogas plant is 4 million euros per 1 MW. Biogas Nord, EnviTec Biogas, Lipp is the middle price segment (3-3.5 million euros). Ukrainian-Swiss brand Zorg offers bio-installations for 2.5-2.7 million euros (assembled by German technology from German components). In all cases, the components for biogas plants are the same. The price is mainly

influenced by the prestige of the brand. In addition, each company includes in the cost of its internal costs (staff salaries, engineering, etc.).

Using the potential of biogas production is an innovative way to meet the energy needs of agricultural enterprises. Complementing the biogas plant with cogeneration installation for the production of heat and electricity will allow the company to make optimal use of energy potential and abandon the purchase of electricity from traditional sources.

5. Conclusions

1. Rapid growth of energy prices, the possibility of reorientation to the cultivation of crops that are processed into biofuels, or the use of livestock products and agricultural plant waste for energy purposes are significant factors for autonomous energy supply of agricultural enterprises and reduce their energy costs in terms of fuel.

2. The types of organic wastes suitable for biogas production are identified: agricultural waste, livestock waste, poultry waste, waste from distilleries, dairy waste, biodiesel production waste, waste fish and slaughterhouse, wastes from juice production, wastes from potato processing, production of chips – cleaning, skins, rotten tubers, sewage (aeration) gases, sewage sludge from municipal sewage treatment plants, solid household waste.

3. The spatial aspect of the use of livestock waste for biogas production in world practice has shown different approaches to the organization of the process. European and world experience of biogas production is analyzed. It is determined that the leaders in Europe are Germany, Denmark and France. Interesting experience of state support and construction of individual biogas plants in China has been studied.

4. Production of biofuels, in particular biogas from waste, and their replacement of purchasing energy resources from traditional sources is currently an effective area of energy supply for agricultural enterprises. The implementation of the Strategy for the efficient use of energy resources for agricultural enterprises of Ukraine is proposed. The main areas of implementation of the Strategy will include: introduction of energy saving technologies; introduction of energy management; use of alternative fuel and energy resources.

5. It is proposed to improve the existing equipment for biogas production based on the development of biogas reactor with uniform stirring and heating which increases the efficiency of biogas production.

References:

1. Kaletnik H. M., Oliinichuk S. T., Skoruk O. P., Klymchuk O. V., Yatskovskiy V. I., Tokarchuk D. M. et.al. (2012). *Alternatyvna enerhetyka Ukrainy: osoblyvosti funktsionuvannia i perspektyvy rozvytku* [Alternative energy of Ukraine: peculiarities of functioning and prospects of development]. Vinnytsia: Edelveis and K, 250.
2. Honcharuk I. V. (2020). Enerhetychna nezalezhnist yak suspilno-ekonomichne yavlyshche [Energy independence as a socio-economic phenomenon]. *Ekonomika ta derzhava – Economy and state*, 8, 71–77. DOI: <https://doi.org/10.32702/2306-6814.2020.17-18.29>
3. Tokarchuk D. M., Pryshliak N. V., Tokarchuk O. A., Mazur K. V. (2020). Technical and economic aspects of biogas production at a small agricultural enterprise with modeling of the optimal distribution of energy resources for profits maximization. *INMATEH – Agricultural Engineering*, 61(2), 339–349. DOI: <https://doi.org/10.35633/inmateh-61-36>
4. Tokarchuk D. M. (2016). Stratehichni napriamy vyrobnytstva biopalyva silskohospodarskymy pidpryiemstvamy Ukrainy [Strategic directions of biofuel production by agricultural enterprises of Ukraine]. *Ekonomika, finansy, menedzhment: aktualni pytannia nauky i praktyky – Economics, finance, management: topical issues of science and practice activity*, 7, 18–26.
5. Skoruk O. P., Tokarchuk D. M. (2012). Ekonomichna efektyvnist vyrobnytstva i spozhyvannia biohazu: svitovi i ukraïnskyi dosvid [Economic efficiency of biogas production and consumption: world and Ukrainian experience]. *Zbirnyk naukovykh prats Tavriiskoho derzhavnogo ahrotekhnolohichnogo universytetu (Ekonomichni nauky) – Collection of scientific works of the Tavriya State Ahrotechnological University (Economic Sciences)*, 2(18), 5, 289–298.
6. Kaletnik G. (2018). Production and Use of Biofuels: Second edition, supplemented: textbook. Vinnytsia: LLC «Nilan-Ltd», 336 p.
7. Kaletnik, G., Honcharuk, I., Okhota, Yu. (2020). The Waste-Free Production Development for the Energy Autonomy Formation of Ukrainian Agricultural Enterprises. *Journal of Environmental Management and Tourism*, XI, 3(43), 513–522. DOI: [https://doi.org/10.14505//jemt.v11.3\(43\).02](https://doi.org/10.14505//jemt.v11.3(43).02)
8. Tokarchuk D. M. (2016). Investytsiine zabezpechennia vyrobnytstva biohazu silskohospodarskymy pidpryiemstvamy Ukrainy [Investment support for biogas production by agricultural enterprises of Ukraine]. *Ekonomika, finansy, menedzhment: aktualni pytannia nauky i praktyky – Economics, finance, management: topical issues of science and practice activity*, 12, 26–35.
9. Palamarenko Ya. V. (2019). Suchasnyi stan ta perspektyvy rozvytku biohazovoi haluzi Ukrainy [Current state and prospects of development of the biogas industry of Ukraine]. *Investytsii: praktyka ta dosvid – Investments: practice and experience*, 21, 54–62. DOI: <https://doi.org/10.32702/2306-6814.2019.21.54>
10. Heletukha H. (n.d.). Perspektyvy biohazu v Ukraini [Prospects for biogas in Ukraine]. *www.epravda.com.ua*. Retrieved from: <https://www.epravda.com.ua/rus/columns/2013/07/3/383399>

11. Law of Ukraine “On animal by-products not intended for human consumption” № 287-VIII of April, 2015. Retrieved from: <http://zakon2.rada.gov.ua/laws/show/3392>

12. Pantsyreva H. V. (2019). Tekhnolohichni aspekty vyrobnytstva biohazu z orhanichnoi syrovyny [Technological aspects of biogas production from organic raw materials]. *Visnyk Kharkivskoho natsionalnoho tekhnichnoho universytetu silskoho hospodarstva im. P. Vasilenka – Bulletin of Kharkiv National Technical University of Agriculture. P. Vasilenko*, 199, 276–290.

13. Skoruk O. P., Tokarchuk D. M., Vsemirnova V. M. (2011). Perspektyvy vyrobnytstva biopalyva tretoho pokolinnia [Prospects for the production of third generation biofuels]. *Zbirnyk naukovykh prats VNAU. Serii: Ekonomichni nauky – Collection of scientific works of VNAU. Series: Economic Sciences*, 1(48), 171–176.

14. Varchenko O., Krysanov D., Shubravska O., Khakhula L., Gavryk O., Byba V., Honcharuk I. (2020). Supply Chain Strategy in Modernization of State Support Instruments for Small Farms in Ukraine. *International Journal of Supply Chain Management*, 1, 9, 536–543. DOI: <https://doi.org/10.32702/2306-6814.2020.17-18.29>

15. Kaletnik G. M., Bilokinna I. D., Pryshliak N. V., Shpykuliak O. G., Tokarchuk D. M., Zdyrko N. G. (2021). Economic aspects of energy efficient and environmentally safe directions for the development of rural areas: collective monograph. Sofia: VUZF Publishing House “St. Grigorii Bogoslov”.

16. Tokarchuk D. M., Furman I. V. (2020). Suchasni enerhoefektyvni tekhnolohii APK [Modern energy efficient technologies of agro-industrial complex]. *Ekonomika, finansy, menedzhment: aktualni pytannia nauky i praktyky – Economics, finance, management: topical issues of science and practice activity*, 4, 99–116. DOI: <https://doi.org/10.37128/2411-4413-2020-4-7>

17. Pryshliak N., Lutsiak V., Tokarchuk D., & Semchuk I. (2020). The Empirical Research of The Potential, Awareness and Current State of Agricultural Waste Use to Ensure Energy Autonomy of Agricultural Enterprises of Ukraine. *Journal of Environmental Management and Tourism*, 11 (7), 1634–1648. DOI: [https://doi.org/10.14505//jemt.v11.7\(47\).04](https://doi.org/10.14505//jemt.v11.7(47).04)

18. Pryshliak N., Tokarchuk D.M. (2020). Socio-economic and environmental benefits of biofuel production development from agricultural waste in Ukraine. *Environmental & Socio-economic Studies*, 8, 1, 18–27. DOI: <https://doi.org/10.2478/environ-2020-0003>

19. Honcharuk I. (2021). Energy needs of the agricultural sector and the potential for addressing them. *Humanities and Social Sciences: Latvia*, 29(1), 95–113. DOI: <https://doi.org/10.22364/hssl.29.1.06>

20. Tokarchuk D. M. (2010). Metodychni osnovy otsynivannia sotsialnoi infrastruktury silskykh poselen [Methodical bases for assessing the social infrastructure of rural settlements]. *Evropejskaja nauka XXI veka Sp. z o.o. «Nauka i studia»*, Polsha, Peremysl, 8, 52–57.

21. Honcharuk I. V. (2020). Enerhetychna nezalezhnist APK na zasadakh staloho rozvytku [Energy independence of agro-industrial complex on the basis of sustain-

able development]. *Investytsii: praktyka ta dosvid – Investments: practice and experience*, 17–18, 29–36. DOI: <https://doi.org/10.32702/2306-6814.2020.17-18.29>

22. Biohazova ustanovka [Biogas installation]. Utility model patent, Ukraine UA 63825 / H. S. Ratushniak, O. H. Lialiuk, K. V. Anokhina, I. A. Koshcheiev; Owner: Vinnytsia National Technical University, bull. № 20 of October 25, 2011.

23. Biohazovyi reaktor z rivnomirnym peremishuvanniam ta pidhrivanniam [Biogas reactor with uniform stirring and heating]. Utility model patent, Ukraine, UA 149480 / H. M. Kaletnik, I. V. Honcharuk, T. V. Yemchuk, O. A. Tokarchuk, V. M. Yaropud, D. M. Tokarchuk, N. V. Pryshliak; Owner: Vinnytsia National Agrarian University, bull. № 47 of November 24, 2021.

24. Vovk V. Yu. (2020). Ekonomichna efektyvnistj vykorystannja bezvidk-hodnykh tekhnologhij v APK [Economic efficiency of waste-free technologies in agro-industrial complex]. *Ekonomika, finansy, menedzhment: aktualni pytannia nauky i praktyky – Economics, finance, management: topical issues of science and practice activity*, 4, 186–206. DOI: <https://doi.org/10.37128/2411-4413-2020-4-13>

25. Ofitsiynyi sait Bioenerheychnoi asotsiatsii Ukrainy [Official site of the Bioenergy Association of Ukraine]. *uabio.org*. Retrieved from: <https://uabio.org>

**EVALUATION OF EFFICIENCY
OF USING RESOURCE POTENTIAL OF RURAL AREAS:
METHODOLOGICAL APPROACH**

Inna Tomashuk¹
Ivan Tomashuk²

DOI: <https://doi.org/10.30525/978-9934-26-193-0-11>

Abstract. *The aim* of the article is to study the methodological tools for assessing the resource potential of the region. *The purpose* of determining the assessment and analysis of the use of resource potential of regions is to ensure economic growth. The principal methodological approach on the basis of the process approach to the management of the quality of economic growth is distinguished – the coordination of the region’s development potential with its results and the substantiation of the strategy for the future on this basis. Assessing the effectiveness of the use of resource potential of rural areas is determined by identifying external and internal threats of socio-economic and environmental orientation. There are two main approaches to assessing the regional economic potential of the region – reproductive and behavioral. Assessment of the resource potential of rural areas should be based on its components: natural, agricultural, human, financial and economic, infrastructural, investment, innovation, business, social, administrative, historical and cultural, marketing, information, recreational potential. *Methodology.* Assessment of the effectiveness of the use of potential includes: analysis of the action of economic entities of the territory on the use of its resources; comparative analysis of absolute indicators of the real and financial sectors of the territory; analysis of the potential of the territory by market relations. The tools for assessing the effectiveness of the use of resource potential of the territory include the analysis of indicators and indicators of the process of realization of resource potential.

¹ PhD of Economics,
Senior Lecturer of the Department of Economics and Entrepreneurship,
Vinnytsia National Agrarian University, Ukraine

² Graduate Student
of the Department of Agricultural Economics Production and International Integration,
National Research Center, Institute of Agrarian Economics, Ukraine

Practical implications. The formation of the assessment of the efficiency of the use of the resource potential of rural areas requires a comprehensive approach, which is carried out using a certain algorithm, which provides for the following stages: analysis of the internal and external environment (preparatory stage); defining a system of indicators to assess effectiveness; calculation of group and integrated indicators of sustainable development of rural areas; analysis of the results of a comprehensive assessment of the effectiveness of sustainable development of rural areas; development and implementation of targeted territorial development programs. Under the assessment of resource potential is understood the definition of its value in value terms in terms of constituent elements: investment, natural resource and labor potential. A methodological approach based on the comparison of the potentially possible theoretical level of use of the region's potential with the available actual indicators has been developed, which allows estimating the reserves according to the analyzed components of the potential. Regarding the development of resource potential, a financial and economic mechanism has been developed to ensure the accumulation of investment resources in the regions through high-efficiency use of the state budget, local budget, borrowed funds and other credit allocations. *Value/originality.* The use of group and integrated indicators allows to identify not only the problems of rural development, but also the reasons for their occurrence, to carry out effective and purposeful solution of tasks to ensure the established strategic goal. Therefore, the methodological approach to assessing the effectiveness of sustainable development of rural areas makes it possible to analyze the current state of rural development. The proposed method of assessing the effectiveness of the use of resource potential for rural development is a necessary element of the analysis of rural development in order to develop and implement tactical, operational and strategic decisions at each stage of regional and national programs.

1. Introduction

Rural areas have a powerful natural, demographic, economic and historical-cultural potential, which, with fuller, more rational and efficient use, can ensure sustainable multisectoral development, full employment, high level and quality of life of the rural population. One of the important tasks of Ukraine's national policy is the transition to sustainable

development. The state can implement this task by rationally and efficiently using the resource potential of rural areas and creating the most favorable conditions for their preservation in the country as a whole.

Especially relevant is the study of the use of natural potential of the territory, taking into account the available socio-economic resources as an object of state regulation and management, analysis of the current state, formation and use of natural resources and labor potential of rural areas. After all, the development of rural areas is a process of stable and balanced development of the rural settlement network and agricultural production based on the implementation of a set of state and local economic, social and environmental measures aimed at preserving and enriching the human potential of the countryside.

In the context of globalization of the world economy, the development of market relations in the country for the scientific substantiation of social and economic reforms of particular importance are issues of managing the efficiency of resource potential of rural areas to develop strategic directions for its improvement.

Today, the definition of the category «efficient use of resource potential of rural areas» is of particular practical importance. Literally, «resource potential efficiency» means the effectiveness of the use of natural resource, human, agricultural production, investment, marketing, financial and economic, infrastructure, social, innovation, business, administrative and information potential. Ensuring a decent life of the rural population and a sufficient level of socio-economic development in rural areas is possible only with a high degree of efficiency in the use of resource potential.

For a more thorough study of the main theoretical and methodological and practical aspects of the efficiency of economic activity in rural areas, it is first appropriate to consider «efficiency» as an economic category and its essential content.

2. Methodical approaches to performance evaluation

The development of territories and the rise of their development to the level of sustainability requires its own holistic concepts. They should be based on existing concepts that reflect the role and responsibilities of state and local authorities in achieving social welfare and social development, and correlate with the concepts of welfare state, social development, welfare and others.

The path to the development of regions and communities begins with the reform of local self-government, namely the assessment of opportunities for self-sufficiency and self-development to create conditions for full satisfaction of the needs of the population and increase its productive energy. At the same time, income from economic activity is seen not as an ultimate goal, but as a means of expanding people's choices in such fundamentally important areas as life, education and professional development, health promotion, economic and social employment, aimed at development and support human personality. Today, local governments have broad powers to manage local affairs.

The concept of «efficiency» has many meanings, although its essence lies in the dialectical unity of two interrelated principles – the maximum result (ie achievement of the goal) with a minimum of costs (living and materialized labor) required to obtain the result.

Currently, there is no single clear definition of efficiency in the economic literature, so there are different views on its criteria and indicators. There are more than 20 classifications of effectiveness in the scientific literature. The most common classification is according to which efficiency is in three types: economic, social, socio-economic. This classification of efficiency is the basis of all other divisions and is therefore general.

Economic efficiency is defined as «the effectiveness of economic activity in the implementation of economic programs and measures, characterized by the ratio of the economic effect (result) to the cost of resources that led to this result» [11].

Some scientists are proposing to calculate the efficiency of real production costs. In this case, the efficiency should be determined by the return on assets, equity and debt capital [4]. It is also proposed to determine the efficiency of advanced resources and the efficiency of resources consumed, as well as the turnover and profitability of funds or their sources [16]. In addition, the efficiency should be determined by the return on capital used, and in the case of borrowing should also take into account financial costs (interest). Profit to determine profitability should be taken that which remains at the disposal of the enterprise, ie net.

One of the main criteria for assessing the activities of the enterprise in a market economy is efficiency – to obtain a certain result at the lowest cost or a given amount of costs. The main indicators of the enterprise in

market conditions are financial stability and profit (profitability). Moreover, the latter means the return on equity and return on total capital invested in the enterprise [15].

In the management literature on management theory [5, p. 8], efficiency is determined by three approaches – target (defines the effectiveness of the system as the ability of the subject to achieve certain goals through the rational actions of its components [11]. Rationalism is to choose the option of using resources that would achieve the goals at the lowest cost), systemic (passive approach, which involves focusing the company on its survival through adaptation to the external environment, focuses on the internal characteristics of the enterprise, making it more suitable for evaluating the activities of budgetary organizations) and selective (provides for a minimum level of satisfaction of all components of the organization, the motives and objectives of which differ [13]. It is important to identify strategic components, as well as determine the degree of their impact on the enterprise as a whole), each of which has its advantages and disadvantages. Therefore, it is possible to achieve positive results by combining these approaches.

Exploring the methodological issues of management efficiency, we can identify three main types of efficiency [6, p. 24–32]: consumer (ratio of goals to needs, ideals, norms); effective (the ratio of the achieved result to the planned goals); costly (ratio of costs to results achieved). These types of efficiency form the following chain: consumer efficiency determines the content of effective, and effective – cost.

In the scientific literature it is suggested to use several methodical approaches to performance evaluation (Figure 1).

Performance management involves the use of the so-called Balance Scorecard (BSC), which includes various financial and non-financial indicators that allow a comprehensive assessment of the value of the enterprise and its performance. Profitability indicators are used in this system as secondary, and the main one is economic added value (EVA) [8].

The problem of assessing the effectiveness of the resource potential of the territory has been studied by scientists for a long time. Obviously, when resources are involved in economic turnover, they and the efficiency of their use must be evaluated like any other product. Assessment of the effectiveness of the use of potential includes: analysis of the action of economic entities

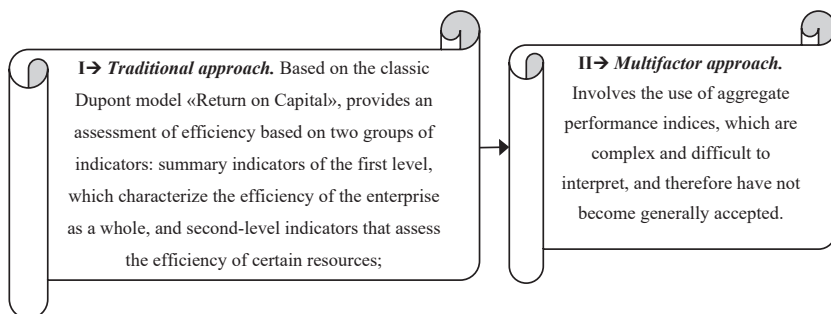

Figure 1. Methodical approaches to performance evaluation

Source: formed according to the results of the study

of the territory on the use of its resources; comparative analysis of absolute indicators of the real and financial sectors of the territory; analysis of the potential of the territory by market relations [12, p. 20].

3. Tools for assessing the effectiveness of the resource potential of the territory

The tools for assessing the effectiveness of the use of resource potential of the territory include the analysis of indicators and indicators of the process of realization of resource potential. Systematicity in the assessment of resource potential and the interaction of certain components with each other is also determined. In the table 1 shows the main features of systematization of types of resource components of the development potential of territories.

Table 1

Systematization of types of resource components of territorial development potential

	A sign of systematization	Type of resources
1	Origin	Human. Material and technological. Financial. Technical and technological. Institutional. Organizational.

Chapter «Economic sciences»

(Continuation of Table 1)

	A sign of systematization	Type of resources
2	Form of existence	Tangible and intangible
3	Content	Raw materials. Production and technological. Knowledge. Intelligent. Innovative. Information. Social. Spiritual and cultural.
4	Time of existence and use	Current (existing at the time of evaluation). Strategic (which may be involved in the future). Backup (can be used at any time if necessary). Potential (which can be obtained by building).
5	Sources of emergence and formation	Natural. Created by society.
6	Systems of territorial economy of the region	Resources of the economic system. Social system resources. Ecological system resources. Human resources and their potential.
7	Object of development	Territory resources. Industry resources. Resources of activities. Enterprise resources. Resources of economic entities. Resources of institutions, institutes. Team resources. Household resources.
8	Direction of development	Resources for educational development. Resources for spiritual and cultural development. Resources for innovation. Resources of economic development. Social development resources. Environmental development resources. Management development resources. Power development resources.
9	Participation in development processes	Resources of production processes. Resources of service processes. Resources of auxiliary processes.

(End of Table 1)

	A sign of systematization	Type of resources
10	Impact on the level of development	Resources for direct positive impact. Resources for indirect positive influence. Resources of direct negative impact. Resources of indirect negative influence.
11	The level of administrative-territorial organization	State resources. Regional resources. Resources of territorial communities. Household resources.
12	Resources of the political system	Positive changes related to political and national trends in the country. International relations related to the change of government. Changing political elites, the emergence and implementation of new innovative reforms in the development of the country and regions.
13	Subject of influence	Resources of public authorities. Resources of regional authorities. Resources of local self-government. Civil society resources.

Source: [9]

Many factors influence the assessment of the efficiency of using the resource potential of the territory. The following main tasks of methods for assessing the effectiveness of the resource potential of the territory can be distinguished:

- to ensure the development of the region’s economy on the basis of the most efficient use of its resource potential;
- to form and evaluate the organizational and production infrastructure of the region, taking into account the requirements of information, financial and organizational technologies sufficient for the implementation of targeted regional projects and programs;
- make optimal use of regional budgets, taking into account the availability of resource potential that provides independent effective development;
- to increase the social level of the population of the region; to create effective tools for the implementation of regional programs based on attracting significant additional investment in regional programs and projects [13, p. 16].

Implementation of these tasks, first of all, involves:

- quantitative assessment of the resource potential of the region as a basis for qualitative analysis of economic processes and trends;
- alternative prediction of the future development of economic sectors as possible objects of using the resource potential of the region;
- assessment of possible changes in the structure of resource potential of the region and development of necessary measures to increase it.

The resource potential of rural areas is a complex system that is interconnected and interdependent. Therefore, it has the inherent features of any system. The first is integrity, which means that all elements of capacity serve a common goal facing the system. The second distinguishing feature of the resource potential of rural areas is complexity. It is manifested in the presence of several constituent elements, each of which is a set of separate parts, which include, in turn, several smaller parts of the potential [4]. The use in the process of planning and reproduction of such system features of resource potential as the interchangeability of its individual elements and a balanced optimal relationship between them opens the possibility of creating an economic system with maximum productivity. As a system of economic relations, the resource potential of rural areas has a sectoral and territorial cut.

According to many economists, the potential implies the need for quantitative interpretation of the hidden capabilities of the object under study. In this regard, domestic and foreign literature offers various methods for assessing the level of potential of the territory. At the same time, each study basically uses many different criteria.

There are two main approaches to assessing the regional economic potential of the region – reproductive and behavioral. Within the first region is considered as a relatively closed system, based on the formed indicators of productivity of factors of production [14]. Using the second approach, the analysis of the set of territories and the relationships that exist between them.

4. Methods of complex assessment of economic potential of the territory

The analysis of methods of complex estimation of economic potential of the territory has some basic approaches (table 2).

In modern economics, two areas of research of resource potential have been formed: «effective» and «resource».

The main approaches to the methods of comprehensive assessment of the economic potential of the territory

	Characteristics of methods
<i>I</i>	The method of establishing the closeness of the links between the basic indicators;
<i>II</i>	Index summation method;
<i>III</i>	Method of interval scoring;
<i>IV</i>	The method of constructing an integrated indicator based on the ranking of territories for each of the basic evaluation indicators;
<i>V</i>	The method of non-interval factoring ranking of territories in conjunction with the method of scoring.

Source: formed according to the results of the study

Within the «effective» direction, resource potential is seen as the ability of the economic system to develop, process resources to meet social needs [12]. Estimation of the size of resource potential is reduced to an estimation of the maximum turnover which the economic link is capable to make at the given quantity, quality and structure of resources.

The resource direction considers the resource potential of rural areas as a set of resources of the economic link. Assessment of resource potential is reduced to determining the cost of available resources, and the level of use of resource potential of rural areas is determined by the ratio of the result to the amount of resources used [14].

The resource potential of rural areas can be realized in different ways in different conditions of place and time. In this regard, it should be noted that since the resource potential of rural areas can be realized only in specific conditions (historical, social, economic, legal, institutional), to consider it outside these conditions does not make sense, as these conditions largely depend on the characteristics its volume, location, efficiency of use.

The production complex of each rural area is part of the entire regional economy. Therefore, the resource potential of rural areas to some extent loses its autonomy and integrates with the potential of other areas [12]. In the process of assessing the economic potential of the territory, a distinction should be made between such concepts as the total amount of resources, the amount of resource potential and the indicator of realization of resource potential, which the territory currently has.

Thus, the resource potential of rural areas is a complex, multifaceted category. Its meaningful interpretation is possible only in the case of studying all its components from the standpoint of a single methodology, determining the criteria and indicators of their overall evaluation. Only then can an adequate description of the potential of a particular area be obtained.

The lack of a single methodology for assessing the level of efficiency of the resource potential of rural areas determines the feasibility of trying to develop it on the basis of generalizing certain provisions of its formation and development.

We have identified an algorithm for estimating the resource potential of rural areas, where the order of successively assessed characteristics contains (Figure 2):

- definition of the purposes and tasks concerning an estimation of efficiency of use of resource potential of rural territories;
- selection and analysis of indicators of resource potential of rural areas;
- formation of a system of indicators for assessing the resource potential of rural areas;
- assessment of the resource potential of rural areas by its components;
- formation of a comprehensive indicator for assessing the resource potential of rural areas;
- determining the compliance of socio-economic development of the region to the available resource potential;
- analysis of the obtained results and development of management decisions on the effectiveness of the use of total resource potential.

According to the specified algorithm, it is expedient to estimate efficiency of resource potential in two stages: the first – the analysis on the basis of a point estimation, the second – the analysis of resource potential on the basis of an integrated estimation.

Based on the existing interregional, interdistrict and district differences and identifying various factors that determine the development of the territory, a model of comprehensive assessment of the efficiency of resource potential of rural areas, including a method of typification and methodology for assessing the use of resource potential of rural areas [1], based on an integrated set of indicators that determine the level of efficiency of capacity use (local level).

The method of typing includes scoring and determining the integrated score for all components of the resource potential of rural areas, provides for

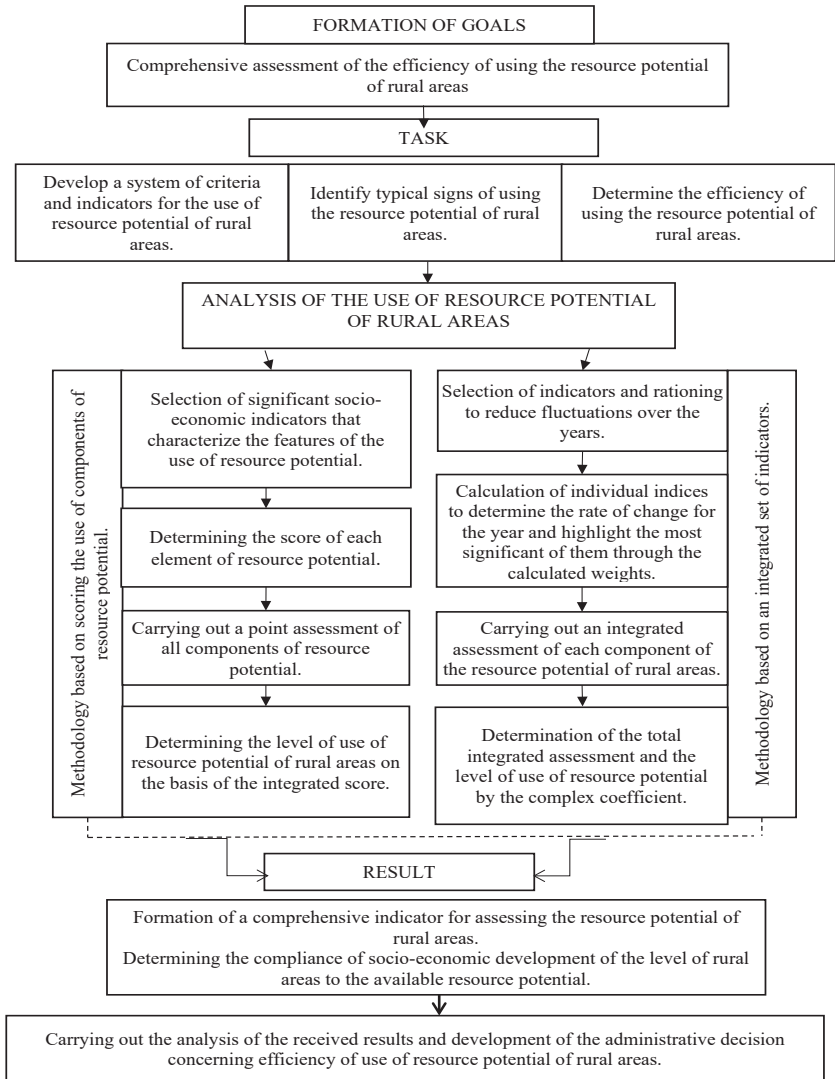

Figure 2. Model of comprehensive assessment of the use of resource potential of rural areas

Source: author's development

quantitative parameters to establish qualitative diversity of socio-economic development of rural areas and determine the nature of their differentiation, which is important for relevant regional policy. equalization, including at the local level [3; 8].

Analysis of the results obtained and ranking of rural areas according to the level of efficiency of their resource potential affects the development of management decisions to improve the efficiency of resource use.

Empirical macroeconomic assessment of the resource potential of the territory can not be obtained directly from the analysis of certain parameters of the region's economy. This is due to the fact that the Gross Regional Product is an integral result of the functioning of a large number of heterogeneous and incompatible natural and economic resources.

Therefore, a multifactor econometric model is used to obtain such an estimate:

$$P_m = \frac{\sum e_i R_i}{1 - d},$$

where P_m – resource potential of the region r ;

e_i – own resource efficiency i ;

R – availability of resources i in the region r ;

d – the share of other factors.

Resource potential is a value that has a time component that allows you to estimate its annual capacity, including not only the actual capacity of the entire capacity of the resource complex, but its potential productivity by loading unused capacity and developing additional over time for public use production:

$$SRP_t = \sum (RP_{et} + RP_{net} + \Delta RP_t),$$

where SRP_t – total resource potential calculated over time t ;

RP_{et} – resource potential, used capacity of the territory over time t ;

RP_{net} – resource potential not used in the current time period t for the needs of social production;

ΔRP_t – additional new capacities of resource potential mastered during the period t and used in social production [2, p. 100].

The most important components in the resource potential are organizational and managerial, logistical, personnel, financial and territorial development potential [11].

In assessing the resource potential, it is emphasized that although the unit of measurement of both resource and production potential are identical, the internal content of these units is completely different: in the case of resource potential they reflect the cost side of the production process, its initial prerequisites, and in the case of production. potential – its result, its final moment.

5. Valuation of total resource potential

It is proposed to value the total resource potential through the estimated parameters of fixed assets, because today they have the most sophisticated official methods of revaluation. However, to reflect the real value of fixed assets, it is necessary to assess them taking into account the level of impact of production (technology) on the environment [1; 3].

Determining the resource potential of the region is described by the model:

$$E\Pi = I_r k_T + I_n k_N + T_p k_p + \Pi_n k_{\Pi} + E_k k_k,$$

where $E\Pi$ – economic potential;

I_T – investment potential;

I_n – innovation potential;

T_p – labor potential;

Π_n – natural resource potential;

E_k – export potential;

$k_T, k_N, k_p, k_{\Pi}, k_k$ – corresponding weighting factors of potentials [7].

The realization of the potential of the territory occurs through its development: «Not a cost, not an exhaustion, but a qualitative transformation, the transition» from resource to resource «and gaining new opportunities» [9]. The indicator of realization of economic potential reflects the achieved level of its use and characterizes the actual return of resources of economic potential. In this regard, it is proposed to use a taxonomic indicator of the level of development (or use) of resource potential, which is a synthetic quantity («equivalent») of all features that characterize the units of the study population). The process of constructing a taxonomic indicator is based on the formation of a matrix of observations, the elements of which are the values of the considered features, which are expressed in specific units.

Assessment of the resource potential of rural areas should be based on its components: natural, agricultural, human, financial, economic,

infrastructure, investment, innovation, business, social, administrative, historical and cultural, marketing, information, recreational potential [7].

The results of the assessment of the level of use of the resource potential of rural areas allow us to judge both the effectiveness of the use of available resource potential and the prospects for changing its qualitative and quantitative state. In this context, there are key factors that will determine the effective use of the existing potential of rural areas (Figure 3).

Improving the efficiency of the use of resource potential of rural areas, according to scientists, should be based on clear principles (Figure 4).

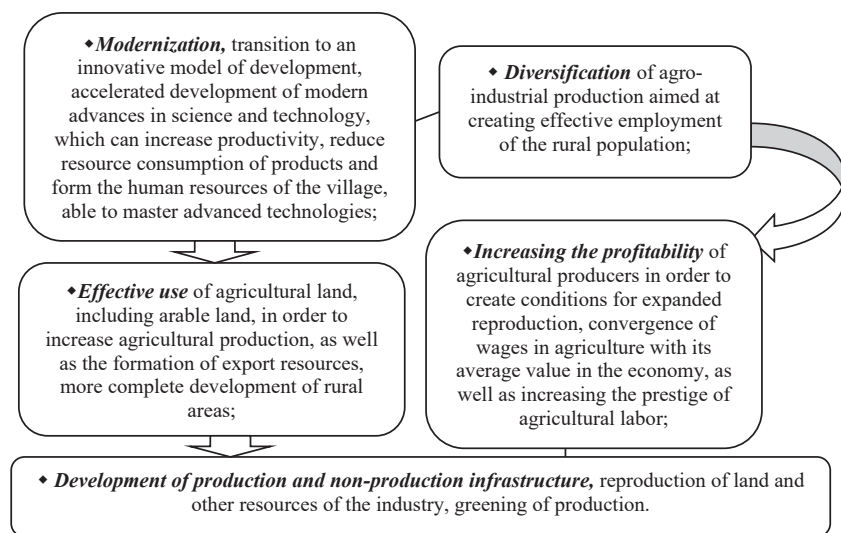

Figure 3. The main factors of effective use of the existing potential of rural areas

Source: formed according to the results of the study

The main subsystems of resource potential are multidimensional categories, they interact, and ultimately economic potential is a function of different potentials: resource and managerial factors. At the same time, the following issues need to be addressed: development of a scientific and methodological approach to the economic assessment of resource potential resources and substantiation of indicators that reflect the value of resource potential.

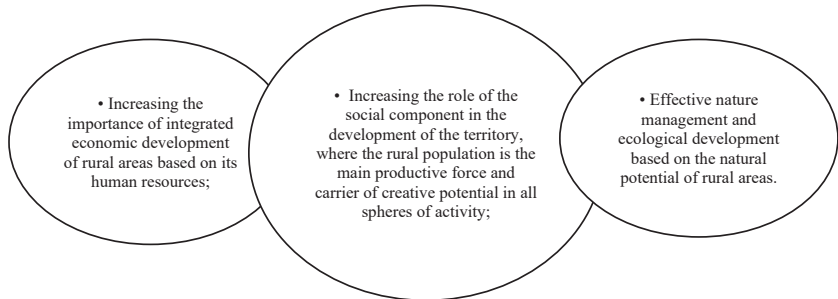

Figure 4. Principles of improving the efficiency of resource use potential of rural areas

Source: formed according to the results of the study

Under the assessment of resource potential is the definition of its value in terms of value in terms of constituent elements: investment, natural resource and labor potential [8]. The assessment of labor potential of the region according to the proposed method is based on economic assessment of labor potential, units of labor resources, differentiated by type of education, calculated by summing all costs directly affecting its formation, by years of their implementation. It is proposed to determine the cost of investment potential resources on the basis of the assessment of fixed and working capital of the region in the territorial context. Assessment of natural resource potential should be carried out for certain types of natural resources: forest, mineral and fauna resources were assessed on the basis of the method of gross productivity; water – «production» method; land – based on the value of production of crop and livestock products; recreational – based on the number of all rehabilitated in the sanatoriums for the year and the average cost of the most typical vouchers (courses).

To solve the problem of estimating individual local potentials, two methods are proposed: the method of production functions and the method of factors of production. The difficulty of using the first method lies in the need to develop a production function for a specific region. However, existing methods take into account only two factors: labor and capital. Based on this, it is proposed to use the methodology presented in the theory of factors of production (in the

creation of value involved factors of production – labor, land and capital). They are sources of income for society: wages, rents and profits.

A system of indicators proposed to assess the economic potential as a whole and its individual local potentials is proposed:

– indicator of the effectiveness of the use of a particular potential of the i -th type:

$$I_{EP_i} = R_i / EP_i$$

where R_i – annual income from the use of the i -th type of economic resource;

EP_i – economic assessment of the potential of the i -th type (annual);

– assessment of the total resource potential of the region:

$$EP_r = \sum_{i=1}^n EP_i$$

where $i = 1, 2, \dots, n$ – the number of individual potentials that are part of the total resource potential;

EP_r – total economic potential of the region;

– an indicator of the efficiency of using the resource potential of the region:

$$IE_{EP} = GRP / EP_r$$

where GRP – gross regional product obtained in the given year;

EP_r – annual value of the resource potential of the region.

When quantitatively comparing the gross regional product produced and its resource potential, three situations can occur.:

– $IE_{EP} = 1$ – gross regional product is equal to the resources sold. This situation is quite rare;

– $IE_{EP} < 1$ – this indicates inefficient use of the region's resource potential;

– $IE_{EP} > 1$ – the economic potential of the region is used effectively [6].

A methodological approach based on the comparison of the potentially possible theoretical level of potential use of the region with the available actual indicators has been developed, which allows to estimate the reserves according to the analyzed components of the potential. Regarding the development of resource potential, a financial and economic mechanism has been developed to ensure the accumulation of investment resources in the regions through high-efficiency use of the state budget, local budget, borrowed funds and other credit allocations.

Regarding the construction of a hierarchical set of characteristics of the resource potential of the region, at zero level place the generalizing indicator Y , which characterizes the potential of the region as a whole and is a set of complex indicators located on the first (X_i) and second levels (X_{ij}).

It is noted that according to the law of synergy, the economic potential of the region is not measured by a simple sum of potentials in terms of resource sources; constituent subsystems are a set of potentials of enterprises in terms of each resource source. The total potential is determined by the formula:

$$Y = \lambda \sum_{i=1}^n \beta_i \sum_{j=1}^m X_{ij},$$

where Y – aggregate economic potential;

X_{ij} – the potential of the j -th enterprise from the i -th source of resources;

n – number of resource sources;

m – number of enterprises in the region;

β_n – 2nd order synergy coefficient;

λ – 1st order synergy coefficient.

The methodological approach is based on the need to take into account the peculiarities of classifications from the standpoint of effective use of resource potential of the region in general and its components in particular.

It is proposed to calculate the qualitative level of resource potential of the region according to the formula:

$$EP = (\sum_{(i=1)}^n K_i X_{vi}) / (\sum_{(i=1)}^n v_i),$$

where K_i – coefficient that characterizes the changes in the qualitative level of resource potential of the region on the i -th indicator;

v_i – significant coefficient of significance of the i -th change in the qualitative level of resource potential of the region in the current period;

n – the number of indicators that assess the change in the quality level of resource potential of the region [4].

It is proposed to calculate weighting factors on the basis of expert assessment by ranking the indicators of resource potential of the region according to the level of significance: from 1 – very significant to 7 – insignificant.

The final stage of determining the total real potential of the region is the total value of component potentials and adjusting it taking into account the

synergy coefficient of the 1st order, which is calculated as the ratio of the difference between total resource potential and standard to standard [12].

Researchers [5; 9] proposed a methodology that provides a quantitative assessment of capacity, increases the validity of management decisions required for indicative planning. This method of assessing the resource potential of the region, based on the comparison of the analyzed and base periods of the economic situation, allows to quantify, first, the level of development of productive forces through the degree of resource use achieved by them; secondly, the priority areas of economic activity in relation to regions, industries, product groups when calculating capacity based on available resources. Such an analysis will solve the problem of priorities in the use of capacity.

6. Formation of enterprise potential

The process of building the potential of the enterprise is one of the directions of its economic strategy and involves the creation and organization of a system of resources and competencies so that the result of their interaction was a success factor in achieving strategic, tactical and operational goals. The following basic methodological approaches are used (Table 3).

There is a list of principles of formation of economic potential of the enterprise:

- any changes in potential occur only through appropriate changes in the media;
- when forming the potential of the enterprise it is necessary to take into account not only qualitative but also quantitative characteristics of individual elements, which must be balanced for the functioning of the enterprise as a whole object;
- when forming the potential of the enterprise it is necessary to take into account the influence of the external environment on the components of the potential of the enterprise and the relationship of elements with the external environment;
- quantitative accumulation of enterprise potential contributes to the emergence of qualitatively new ways and opportunities for enterprise development;
- the development of the enterprise in the long run is the causal basis for the formation of its new potential, and the created potential of the enterprise is the causal basis for its further development.

**Methodological approaches to the description
of the structure of economic potential**

№	Methodological approaches	The essence of the approach
1	<i>System approach</i>	First, the parameters of the product are formed: what to do, with what quality indicators, with what costs, for whom, in what timeframe, at what price. Then the input parameters are determined: what resources and information are needed to implement internal business processes. The need for resources and information is predicted after studying the requirements for organizational and technical potential of the enterprise (level of technology, technology, organization of production, labor and management) and environmental parameters (political, economic, technological, socio-demographic, cultural environment and infrastructure of the region). Feedback communication between suppliers (input), customers (output), external environment and the potential of the enterprise is necessary to adapt the potential as a system to change customer requirements for products, market parameters, the emergence of organizational and technical innovations.
2	<i>Functional approach</i>	It involves finding completely new, original technical solutions to meet existing or potential needs. The need in this case is considered as a set of functions that must be performed to meet it. After defining the functions (for example, marketing, research, supply, production, financing, etc.), several alternative options for capacity building for their implementation are identified and the one that ensures maximum aggregate cost efficiency is selected. The application of this approach, in contrast to the focus on «yesterday's» world standards, allows you to best meet new needs and provide a sustainable competitive advantage.
3	<i>Reproductive approach</i>	Focused on the constant renewal of production with lower resource consumption and higher quality compared to similar products in this market to meet customer needs. This means that the main element of this approach is the mandatory use of the base of comparison of the best similar products at the moment, adjusted before the start of development of new products.

(End of Table 3)

№	Methodological approaches	The essence of the approach
4	<i>Normative approach</i>	It is to establish for the most important elements of the potential standards of quality and resource intensity of products, workload of technical facilities, market parameters and efficiency of use of resource potential for the development and adoption of management decisions. It should be noted that the established standards must meet the requirements of validity, complexity, efficiency and viability.
5	<i>Integrated approach</i>	Provides for the need to take into account technical, environmental, economic, organizational, social, psychological and other aspects of the enterprise. If even one aspect is ignored, the problem will not be completely solved.
6	<i>Integration approach</i>	In the process of building the potential of the enterprise aims to study the strengthening of relationships, integration and strengthening of interaction between its individual elements.
7	<i>Dynamic approach</i>	Associated with the need to consider the potential in dialectical development, in establishing cause-and-effect relationships and subordination based on a retrospective analysis of the behavior of similar systems over a period of time.

Source: formed according to the results of the study

When forming the economic potential of the enterprise should take into account the properties of the economic system (Table 4).

According to the resource concept, the economic potential of the enterprise is considered as a system of resources that interact and determine the results achieved.

According to the resource concept in the structure of the potential of the enterprise the following main elements are distinguished [2; 4]:

- technical resources (production facilities and their features, equipment, materials);
- technological resources (technologies, available competitive ideas, scientific developments);
- human resources (qualification, demographic composition of employees, their desire for knowledge and improvement, intellectual capital);
- spatial resources;

Properties of the economic system according to the existing classification

№	Property of the economic system	Essential characteristics of the property
1	Integrity	A system is an integrity, the properties of which are revealed only by the interaction of its elements.
2	Polystructural	The system consists of a number of parts.
3	Complexity	The economic system is determined by the heterogeneity of components, different and hierarchical relationships between them.
4	Dynamics	The system has constantly changing parameters and is characterized by stochastic behavior.
5	Uniqueness	At any time, the system has its own resources and organizational capabilities.
6	Adaptability	Assumes adaptability of system parameters to constantly changing conditions.
7	Synergy	The purposefulness of the elements of the system enhances the efficiency of its operation.
8	Multiplicity	Geometric dependence of detection of positive and negative effects of functioning of elements of system.
9	Extreme	Elements of the economic system are marginal in nature, which determines its shape.
10	Antientropy	Ability to counter destructive trends.

Source: formed according to the results of the study

– information resources (quantity and quality of information, channels of its distribution, etc.);

- resources of the organizational structure of the management system;
- financial resources (availability and sufficiency of equity and debt capital, asset status, liquidity, availability of credit lines).

It should be noted that the resource approach does not give a complete description of the structure of the economic potential of the enterprise. In this case, only one aspect is considered – resources.

Economic category of economic potential determines the potential of productive forces and production relations. In his research, a methodological approach is put forward that reveals the dialectic of formation, potential of a new product and consumption.

Methodological principles of economic potential distinguish its elemental composition by the following types: production potential, labor potential, innovation potential, investment potential, the potential of basic industries and territories, the potential of administrative and production systems. Economic potential is formed under the conditions of its constant realization and future recovery at a higher level [4; 5].

Economic potential is, firstly, the total productive labor force of able-bodied members of society, and secondly, the property of the economy, industries, enterprises to carry out production and economic activities, produce products, services, meet social needs, ensure the development of production and consumption [1].

The formation of the economic potential of the enterprise is carried out in the maximum possible volume of production of material values and services in conditions that ensure their fuller use over time and productivity of a certain number of existing economic resources [10].

The formation of the economic potential of the enterprise is performed on the basis of personnel, production, innovation and organizational and managerial potential. It is the economic potential of the enterprise is the basis for making strategic decisions, determining the directions of its development, the formation of a program of action for the future, the basic criterion of management processes [11].

The constituent components of the enterprise's potential together create its balanced general and internal structure. Quantitative and qualitative relationships in the structure of enterprise potential show the relationship and balance of the following elements: production, organizational structure and management, marketing and finance, convincingly formulated in the graph-analytical model «Capacity Square», which provides theoretical aspects of business decisions [2].

The ratio in the structure of economic potential of objects should be represented by the following elements:

- potential of the enterprise;
- potential of the industry;
- potential of the region (territory);
- state potential;
- global (transnational);
- economic potential [5].

Continuous support of proportionality and development of potential components ensures maximum profitability of the enterprise and its highest value [1].

The essence of proportionality, which operates in the organization of the elements of the potential of the enterprise – is their quantitative and qualitative ratio, the relationship and balance of potential.

A systematic approach to the formation of enterprise potential is productive, as it allows to systematize its structure and determine the dynamics of development in the transformational conditions of the economy. The potential of the enterprise is a system of various opportunities of resources under the condition of their mobilization in development strategies.

The essence of the system approach to the formation of enterprise potential shows the process of building a system that defines a holistic set of components that have unity with the external environment and are a subsystem of the global system. These properties of the potential of the enterprise allow the formation of such postulates of the system approach, which should be taken into account when forming its system:

1. The purpose of the system of enterprise potential – is the state of the system, to which it goes under the condition of maintaining its structural organization.

2. The structure of the potential of the enterprise is a set of components of the system, which is defined and organized, combines local goals to best achieve the main goal.

3. The number of structural components of the system of enterprise potential and their relationships should be minimal, but sufficient to achieve the main goal.

4. «Entry» of the enterprise potential system is a component that enters the system, for example: raw materials, energy materials, fixed assets, personnel, information.

5. «Output» of the enterprise potential system is a component that produces the system, for example: products, goods, services.

6. The external environment determines the components of the macroenvironment and microenvironment of the system, with which there are direct and indirect links.

7. Feedback of the enterprise potential system is the requirements, proposals and other information defined in the system.

8. The development of the system of enterprise potential determines the improvement of the system on the basis of the use of competition mechanisms, economic laws and the implementation of market levers.

The system of enterprise potential is determined by the properties by which it can be distinguished from the potential of competitive enterprises that exist in a market environment.

The formation of the system of enterprise potential is based on the principles of a systematic approach that explains the economic incentives and constraints in a market economy.

The basic principles of a systematic approach to building the potential of the enterprise determine: a) integrity; b) structure; c) the relationship between structure and environment; d) the hierarchy of the system.

Given the above, we can formulate a definition of certain types of enterprise potential, namely:

Economic potential of the enterprise – a set of capabilities of the enterprise to identify, shape and satisfy consumers with products and services in the process of optimal interaction with the external environment, the rational use of economic resources [4; 5]. The model of formation of economic potential of the enterprise is presented in figure 5.

The existing potential of the enterprise is a property of the enterprise, which is manifested in the ability to achieve the goal of management without changing the size and structure of resources.

Realized potential of the enterprise – the existing potential that is directly used to achieve a certain goal at the time of evaluation. To realize the existing potential, it is necessary that the properties of the carrier meet the requirements of the market, as well as the current costs of its implementation.

Unrealized potential of the enterprise is a part of the existing potential of the enterprise, which at the time of assessment is not used due to internal or external factors, and whose existence is appropriate only as a temporary position or as a reserve.

The optimal potential is characterized by the optimal structure of resource components of the system in terms of adoption, documentation, control and coordination of management decisions in order to save resources and improve the investment attractiveness of the enterprise.

The potential of the enterprise is characterized by various characteristics (Figure 6):

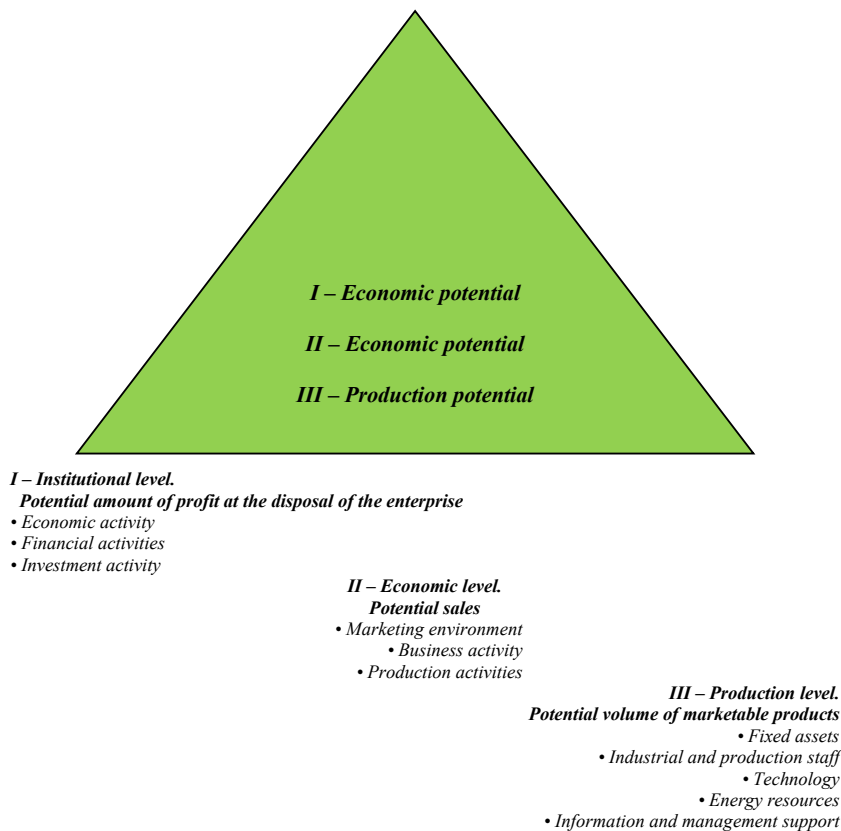

Figure 5. Model of formation of economic potential of the enterprise

Source: formed according to the results of the study

– Comprehensive description of the resources needed for the functioning of production and acceleration of scientific and technological progress.

– Systematic characteristics of tangible and intangible factors that ensure the achievement of production, and the ability of the resources of the economic system to perform its tasks.

– According to the resource characteristics of the potential, the value of the entire property complex of the enterprise, intangible assets and business

activities is estimated, which determines the effectiveness of the potential. An active position in theory is taken by the resource concept of potential.

The dynamic characteristics of the organization of enterprise potential are formed by the laws of synergy, awareness-ordering, self-preservation, unity of analysis and synthesis.

Building a system of enterprise potential is a complex mechanism that combines incentives and constraints, hard technology, innovation, free creativity and regulatory requirements. Entrepreneurship is a unique intangible factor of production in the system of production potential of the enterprise.

The essence of entrepreneurship is the most effective combination and use of land resources, capital and labor to meet the needs of consumers with goods different from competitors in order to obtain entrepreneurial

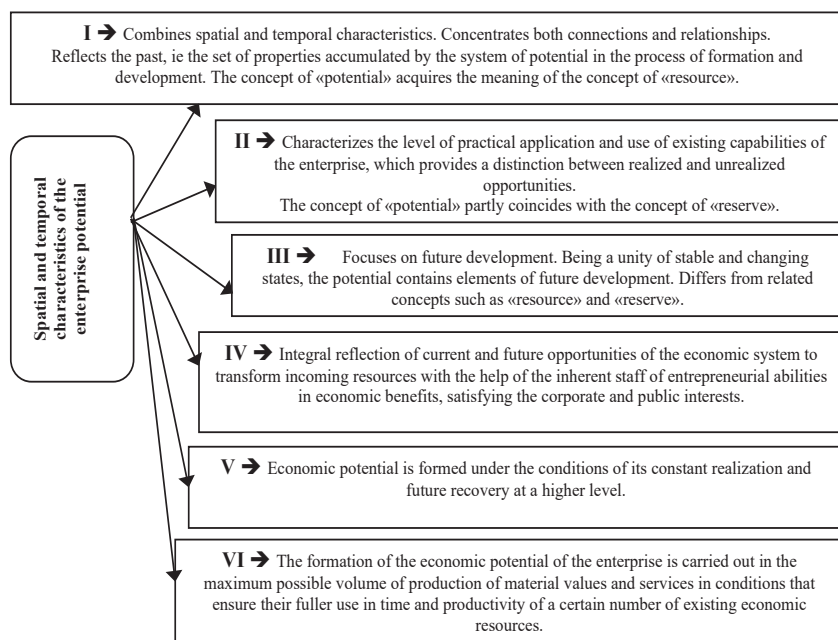

Figure 6. Characteristics of the potential of the enterprise

Source: formed according to the results of the study

income. As world experience shows, entrepreneurship itself is a powerful «locomotive» that can significantly accelerate the reform of the domestic economy on a market basis, which will provide an opportunity to ensure proper growth of production and welfare.

7. Findings

The transformation of socio-economic relations currently taking place in Ukraine necessitates the formation of a mechanism for the effective use of economic potential of the region, combining a system of levers and incentives that can ensure the effective use of investment, innovation, natural resources and labor potential. Modern socio-economic development of the regions of Ukraine largely depends on the degree of use of economic potential concentrated in this area. This is especially true in the crisis situation in which the country is now. It is by identifying and using one's own economic potential that it is possible to establish economic ties that will make it possible to overcome the economic downturn.

Thus, based on the fact that the purpose of determining the assessment and analysis of the use of resource potential of regions is to ensure economic growth, distinguish a principled methodological approach based on a process approach to quality management of economic growth – matching the region's development potential with its results.

In addition, assessing the resource potential of rural areas and the effectiveness of its use allows to group rural areas by the most important indicators, build forecasting models to determine the range of possible trajectories of their development, specify areas and tools of state support of rural areas with differentiated characteristics of resource potential investment attractiveness.

8. Conclusions

The resource potential of rural areas of the country and its individual regions consists of the following most important elements: natural resource; demographic; tourist-recreational and industrial.

Rational use of resources is considered a priority of Ukraine's national interests. Assessment of the current state and resource potential of the development of «rural areas» provides an opportunity to make forecasts, strategies for regional and national development, to determine additional factors of influence to improve welfare, enhance well-being and improve living standards.

Improving the efficiency of resource management, ensuring its rational use is largely associated with qualitative changes in the composition of resources and improving the efficiency of their management. The task of improving the efficiency of resource management of rural areas is, first of all, to improve the use and management of resources of rural areas and to increase their integrity, which is manifested in their close relationship.

Diagnosis of resource potential depends on the definition of the criterion and the formation of the corresponding system of indicators. The criterion must characterize the essence of efficiency as an economic category and be common to all parts of social production. The criterion does not meet the needs of quantification and therefore cannot be quantified. It is a generalized formation of the ultimate goal.

One of the main methods used to identify the features of the economic potential of the regions of Ukraine is the mathematical and statistical method. It consists in mathematical calculations of such indicators as natural resource, production, labor, investment and export potential. On this basis, the overall integrated indicator of the economic potential of the region is calculated. To determine the composition and structure of the region's potential, a comprehensive analysis of its economic component was used, which allowed to take into account most of the conditions and factors influencing the formation and effective use of the region's potential.

Ensuring a high level of resource potential of the regions is possible only on the basis of the introduction of planning and forecasting mechanisms for its development. The main subsystems of resource potential are multidimensional categories, they interact, and ultimately economic potential is a function of different potentials: resource and managerial factors. Therefore, the methodological approach to assessing the effectiveness of sustainable development of rural areas makes it possible to analyze the current state of rural development. The use of group and integrated indicators allows to identify not only the problems of rural development, but also the reasons for their occurrence, to carry out effective and purposeful solution of tasks to ensure the established strategic goal.

References:

1. Baldynyuk, V., & Tomashuk, I. (2020). Use of land resource potential of rural territories of Ukraine in the conditions of transformation changes. *The scientific heritage*, 50(4): 6–17.

2. Bondarenko, V. M. (2012). Resource potential of the region: methodology of formation and prospects of use. Vinnytsia: RVV VNAU: PE Balyuk I.B., 373 p.
3. Goncharuk, I. V., & Tomashuk, I. V. (2017). Influence of ecological and economic factor on features of organizational and economic mechanism of use of resource potential of rural territories. *Economics, finance, management: current issues of science and practice*, 4(20): 55–62.
4. Koshchinets, V. V. (2011). Methodological tools for assessing the resource potential of the region. *Public administration: improvement and development*, 10. Retrieved from: <http://www.dy.nayka.com.ua/?op=1&z=436> (accessed 26 October 2021).
5. Kutsenko, A. V. (2008). Organizational and economic mechanism of management of efficiency of activity of the enterprises of consumer cooperation of Ukraine: monograph. Poltava: RVV PUSKU, 205.
6. Markina, I. A. (2000). Methodological issues of management efficiency. *Finance of Ukraine*, 6: 24–32.
7. Mazur, K. V., & Tomashuk, I. V. (2019). Governance and regulation as an indispensable condition for developing the potential of rural areas. *Baltic Journal of Economic Studies*, 5(5): 67–78.
8. The problem of determining efficiency. Methodical approaches to assessing the effectiveness of the enterprise. Retrieved from: http://pidruchniki.com/1854051647541/ekonomika/problema_viznachennya_efektivnosti_metodichni_pidhodi_otsinki_efektivnosti_diyalnosti_pidpriyemstva (accessed 27 October 2021).
9. The potential of territorial development: methodological principles of formation and growth: monograph (2017) / O. Yu. Bobrovska, T. A. Krushelnytska, M. A. Latin [etc.]; for the head ed. d. state. manager, prof. O. Yu. Bobrovska. Dnipro: DRIDU NADU, 362 p.
10. Polynev, A. O. (2003). Interregional economic differentiation: methodology of analysis and state regulation. Moscow, 104 p.
11. Riabkova, O. V. (2013). The essence of the effectiveness and efficiency of the enterprise. Retrieved from: http://mev-hnu.com/load/2013/7_konkurentnij_potencial_pidpriemstva_metodi_ta_mekhanizmi_pidvishhennja/37-1-0-246 (accessed 12 September 2021).
12. Samaruha, V. I., & Taksir, K. I. (2002). Program of socio-economic development of the Kazan region until 2005: monograph. Kazan: BGUEP, 200 p.
13. Sevka, V. S. (2009). Issues of assessment methods of the region's potential. *Finance of Ukraine*, 4: 14–20.
14. Smirnova, T. G., Selyakova, S. A., & Kozhina, E. N. (2010). Production potential of the rural area: state and prospects / ed. T.V. Uskovi. Vologda: ISERT RAS, 88 p.
15. Shmalen, G. (1996). Fundamentals and problems of enterprise economics / trans. with him. Moscow, 512 p.
16. Sheremet, A. D., & Saifulin, R. S. (1995). Methods of financial analysis. Moscow: Infra-M, 176 p.
17. Shelegeda, B., Savchenko, M., & Savchenko, I. (2003). Economic potential of the region: laws of formation and evaluation methods. *East*, 4: 28–33.
18. Shpykuliak, O. H., & Mazur, H. F. (2014). Institutional principles of social capital formation in the mechanism of rural development. *Economics of agro-industrial complex*, 8: 63–71.

**ANALYTICAL INFORMATION IN THE MANAGEMENT
OF AGRICULTURAL ENTERPRISES IN THE CONDITIONS
OF EUROPEAN INTEGRATION**

Olena Tomchuk¹

DOI: <https://doi.org/10.30525/978-9934-26-193-0-12>

Abstract. *The purpose* of the article is to substantiate a set of theoretical and practical principles for provision of analytical information to the management system of agricultural enterprises. *Methodology.* Methods of theoretical generalization and concretization, Internet resources have been used in this study. *Results.* Two interacting systems, namely a managing and managed ones, have been identified. The managing system involves the subjects of management, i.e. the apparatus of enterprise management. It is the managing system that implements the main functions of management (planning, organization, motivation, control) through management decisions. The managed system involves the object of management, i.e. it is economic (operational, investment, financial) activities of the enterprise. The process of business management is carried out through the collection of information about the object of management and the results of previous decisions, analysis of this information and making new management decisions based on such analysis. The objects, stages and technology of organization of analytical process are formed. The integration of approaches, methods and models of support for management decision-making at the agricultural enterprise is revealed, namely indicator method, resource-functional approach, integrated approach, approach based on the theory of economic risks. The financial and economic activity of LLC “Courland” in the context of using information support in its management system by the main economic indicators of resources and results, production program and level of marketability of the main agricultural products, liquidity of the balance, financial stability and solvency, business activity, indicators

¹ PhD in Economics, Associate Professor,
Associate Professor of analysis and audit Department,
Vinnitsia National Agrarian University, Ukraine
ORCID: <https://orcid.org/0000-0003-0974-8018>

of profitability of the enterprise. It is substantiated that the introduction of management system and timely data processing allowed the company to achieve positive changes in the results and form trends towards the growth, organize the work of structural units, main activities, and to achieve economic effect. Organizational regulations on the organization of analytical service and coordination of work of persons engaged in analysis and conducting analytical work are proposed. It is proved that Regulations on the Analysis Department should be the main organizational regulation, on the basis of which the methodological guidance, organization and conduct of economic analysis at the enterprise is carried out. *Practical implications.* Taking into account the impact of features of the agriculture on the formation of analytical information enables to carry out a comprehensive assessment of economic and social results, to develop quantitative and qualitative indicators of efficiency. *Value/originality.* The integration of approaches, methods and models that has been considered will increase the rationality of management decisions by adjusting the probability of the event occurrence and selecting the best project among the alternatives by the criterion of profit maximization. Implementation of the management system and timely data processing allowed the company to achieve positive changes in the results and to form growth trends, organize the work of structural units, the main activities, and to achieve the economic effect. Determination of management elements in the digital space will let domestic enterprises take a proper place in the international cooperation and competitive advantages in the market.

1. Introduction

At the beginning of the third millennium, Ukraine made many efforts to integrate into the modern European and world community. This fact is directly related to the need to bring to a high level all spheres of economic life. Domestic enterprises are at a very difficult stage of their development. An important problem of enterprise management is the formation and maintenance of its competitiveness in conditions of constant changes in the external environment. The purpose of the analytical support of the company's managers is to provide the company's management with complete, timely, and reliable information for current and strategic management decisions. The main source of such information is the data of current accounting, which

are systematized in the reporting. Such reporting is important because it is used not only for economic analysis of the individual enterprise in order to obtain the information necessary for management, but also to summarize the results in the scale of industries and the economy as a whole. The accounting and reporting system should be based on accepted in world practice methodological principles and approaches to analytical research aimed at the comprehensive impact on the enterprise to ensure a profit and strengthen its financial position in the market. Aware of this indisputable fact, generated by harsh business conditions, domestic enterprises, using modern methods of obtaining and analyzing information, are gradually creating a strong information – analytical base for sound – effective management decisions.

This process is successfully implemented in large industrial and commercial enterprises, and is slowly being implemented in agriculture.

Despite the gradual improvement of agricultural production processes, their acquisition of world best practices in crop and livestock, the use of the latest technology and advanced technologies, farmers are still unable to provide themselves with a sufficient level of reliable, understandable and important information. the results of their activities. Thus, a natural question arises: how, given the specifics of agriculture, and not having a strong information base, we can say about the validity of production indicators and accurate planning of rural enterprises.

The peculiarity of agricultural production is its unconditional dependence on natural and climatic conditions. No farm, without being able to fully predict the meteorological situation during the sowing campaign or harvest, risks losses from non-compliance with the set of agronomic measures or the impossibility of their implementation. Thus, in our opinion, the main source of information support in the operation of the enterprise is analytical information.

2. Analytical information as a means of preparing management decisions

Due to globalization and integration processes in the economy, the reform of accounting and reporting in accordance with international financial reporting standards, the role of analytical information in the activities of each business entity is increasing. With the help of analytics,

the company's development strategy is developed, the choice of optimal options for management decisions is substantiated, their implementation is monitored, the company's performance is assessed and the causes of problems and available reserves are identified.

The choice of such a decision must be provided with reliable and comprehensive information about the object for which it is made.

In the enterprise management system there are two interacting systems: control and managed. The control system is the subjects of management, ie the apparatus of enterprise management.

It is the management system that implements the main functions of management (planning, organization, motivation, control) through management decisions.

The managed system is the object of management, that is, it is the economic (operational, investment, financial) activities of the enterprise. The process of business management is carried out through the collection of information about the object of management and the results of previous decisions, analysis of this information, and making new management decisions based on such analysis.

To optimize the management the owners (managers) must have a clear idea of the dynamics and nature of changes in the activities of the business entity. Obtaining such information is possible as a result of the analysis. In the process of analysis, the primary information is processed, the results of the analysis are generalized and systematized. And only on the basis of analytical conclusions management decisions are made.

Economic situations that arise in the process of economic activity require several options for a solution, their justification by analyzing economic activity and choosing the best management solution.

In turn, Z.B. Litvin and V.M. Seredinskaya emphasizes that "the formation of direct and reverse flows in management is possible only on the basis of an analytical research" [1].

That is, the analysis is between the controlled and the control system. It provides direct (control-to-controlled) and feedback (controlled-to-control) communication between these systems. In direct communication, the analysis provides the managed system with the information it needs to make management decisions. Conversely, it provides the management system with information on the effectiveness of management decisions,

deviations, identified reserves, and other information, on the basis of which the following management decisions are formed, which are again transmitted to the management object through direct communication (Figure 1).

Based on the place of analysis in the management system of the enterprise reveals its main purpose (main goal) – to provide information to the management of the enterprise to make effective management decisions.

We believe that analytical operations are divided into several types: mechanical, which include the receipt, registration, transmission and storage of documents; processing – grouping, methods of logical obtaining of the indicator, the performance of various calculations, etc.; creative, include the compilation and formation of final data, analytical conclusions, and proposals, development of recommendations and more.

The set and sequence of analytical operations form information phases, which in turn constitute the stages of the analytical process: preparatory, analytical processing (procedural), final (Figure 2).

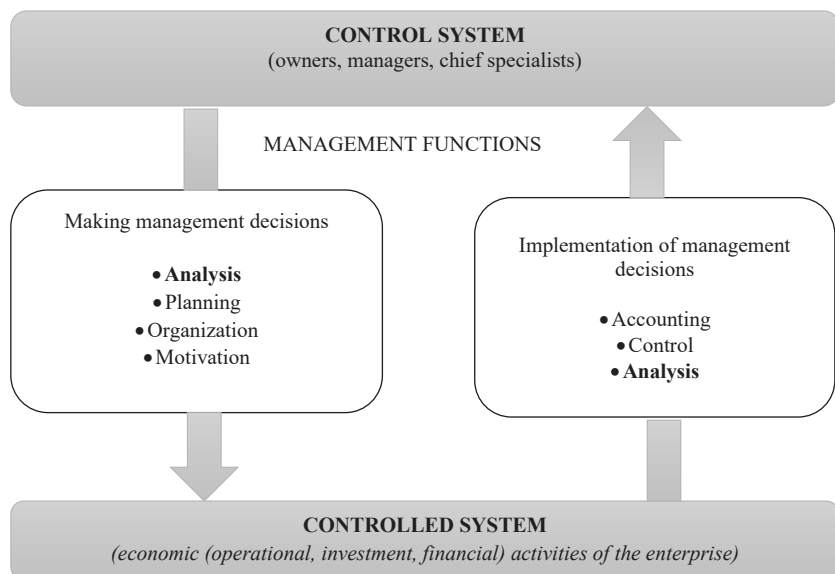

Figure 1. The place of analysis in the enterprise management system

Source: suggested by the author

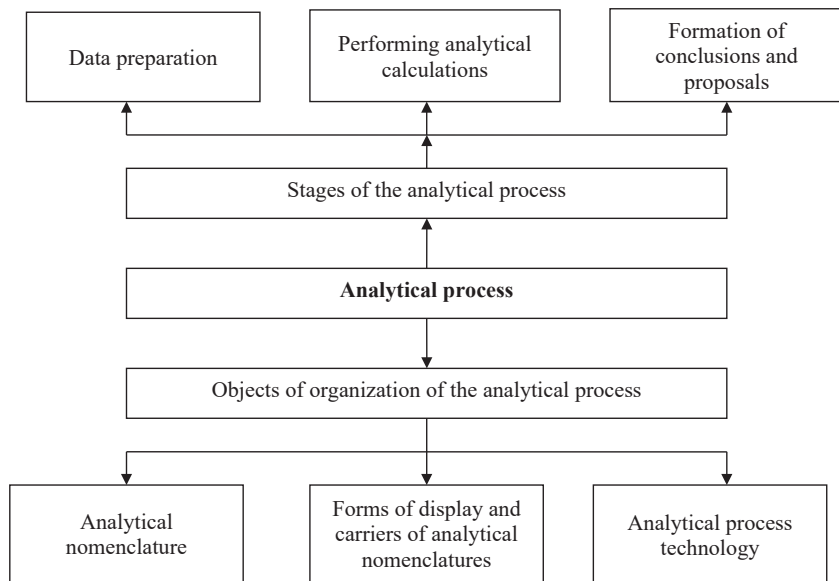

Figure 2. Objects and stages of organization of the analytical process

Source: [3]

The main element of the analytical process is analytical nomenclatures. Analytical nomenclature means a system of data that is reflected in plans, estimates, norms, standards, actual data of primary and consolidated accounting documents on the state of funds, sources of their formation, economic processes, and results of economic activity of the enterprise. This also includes a variety of physical and cost indicators. The composition of analytical nomenclatures to be analyzed depends on the direction of activity and specialization of the agricultural enterprise and, which is very important, on the period for which the analysis is conducted. According to the sequence of use of analytical nomenclatures in the analytical process, they are divided into primary (input), intermediate, final (result, generalizing) [2].

One of the types of carriers of analytical nomenclatures are forms of display of normative, planned, estimated, accounting, reporting, technical data. Carriers of analytical nomenclatures can also be ready-made documents that are created in the process of accounting, control, planning. Such media

include plans, estimates, primary documents, accounting records, reporting forms, minutes of production meetings, acts of inspections, and audits.

In the analytical process, special internal media also appear, which are usually displayed in the form of analytical and calculation tables, graphs, charts, analytical conclusions, and notes.

Developed internal media of analytical nomenclatures are collected in albums of carriers of analytical nomenclatures. Such albums are formed on topological grounds in terms of stages of the analytical process.

The technology of the analytical process is the production of information.

The analytical process of information production is determined by the methods and techniques of data collection, storage, and processing. The basis of the analytical process is certain operations. The set and sequence of analytical operations form a technological phase (stages), which in turn form the technology of the analytical process [4].

Thus, the technology of the analytical process is a process of processing of information, which consists of three main stages. Each of the stages has its own procedures and analytical operations (Figure 3).

The first stage of the technology of the analytical process – preparatory – is to verify the input information and prepare data to be analyzed – is very important, because the reliability and completeness of the information depend on the results of analysis, which affect management decisions. That is, at the preparatory stage carry out a set of works to prepare information for the next analytical processing.

The second stage – procedural – ensures the implementation of analytical procedures (calculations), it is quite complex and depends on the correctness of the chosen method of calculation. The procedures of the second stage of the analytical process are various methodological, technical, and analytical calculations, which are used to process information and make it suitable for use in management decisions. The stage of analytical processing is the main one, as it depends on the quality and completeness of research and evaluation of phenomena and factors that caused certain results of activities, and accordingly – the validity of conclusions and proposals based on the results of this analysis.

The third stage – the final stage of the technology of the analytical process – is the creation (formation) of effective, source information. This stage involves the generalization of the transformed analytical information and preparation on their basis of conclusions, proposals, and

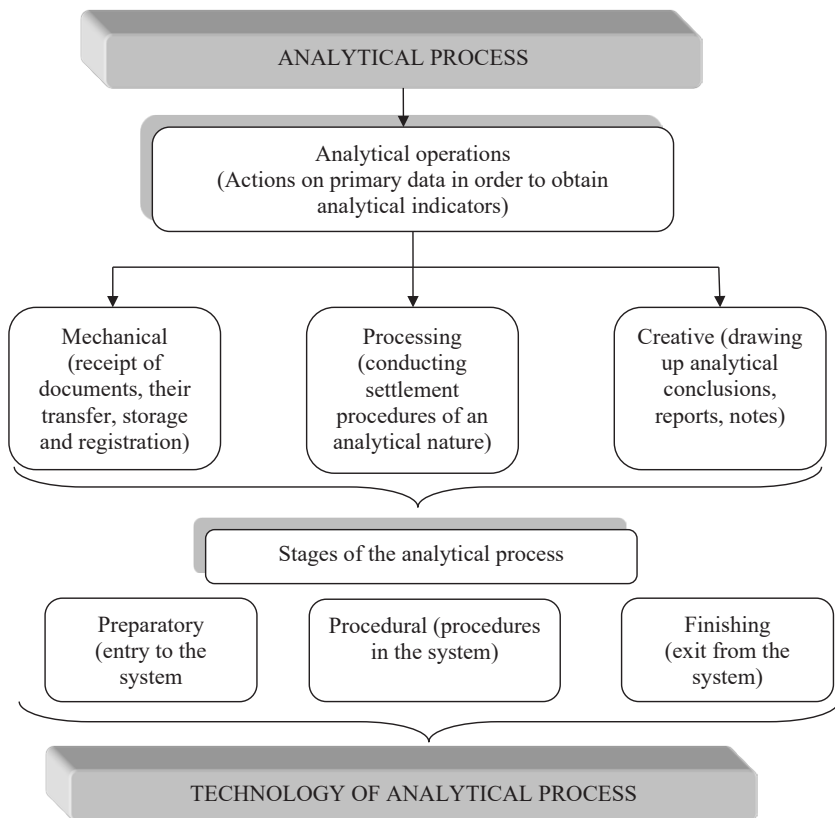

Figure 3. Analytical process technology

Source: [2]

recommendations for improving the economic activity of the enterprise, eliminating shortcomings and the use of reserves [2].

The technology of the analytical process, as a process of processing information, involves the implementation of certain procedures and analytical operations. Their phased implementation is regulated by certain instructional materials.

The quality of analytical work depends on sufficient information content. This means that when determining the sources of information it is necessary

to take into account the limitations and redundancy of information, as both negatively affect the results of the analysis. In the absence of information, it is difficult to properly understand the situation, evaluate it and make the right decision [5].

Lack of information makes it impossible to solve tasks, achieve certain goals.

However, it should be borne in mind that there is a problem with redundant information. The concept of redundant information for each of the levels of government is specific. Excessive information hinders its rapid processing, analysis, and generalization, which can lead to unreasonable conclusions.

To analyze the financial and economic activities of LLC “Kurland” analysts have to use a large amount of economic, financial, agrobiological, environmental, zootechnical, engineering, and other information, which is formed both inside the company and outside the company. To ensure the reliability of the analysis data, such a variety of sources of information necessitates the observance of uniform qualitative characteristics of the input information.

As noted by Mishchuk, G.Yu., Dzhigar, T.M., & Shishkina, O.O., the logical conclusion of the analytical study is to obtain results in the form of structured information, which provides an opportunity to achieve the main purpose of the analysis [6].

Effective use of the results of analytical work requires proper generalization, which could ensure the completeness of assessments and conclusions, timeliness of receipt of materials, their compliance with management requirements. Summary results should cover all aspects of the study, from identified lost profits and unfulfilled measures to information on hidden reserves and over fulfillment of plans.

Forms of generalization and presentation of conclusions on the results of the analysis can be various. The form and content of the conclusions depend on the purpose and depth of the analysis and the period for which the research is conducted.

So, in the process of conducting an analytical study, it should be clearly defined in what form the results of the analysis are presented. If the use of tables is provided for registration of results of the analysis, they should be developed in advance. Layouts of analytical tables are designed as appendices to the analytical research.

As mentioned above, at the stage of formation of a market economy and European integration there is a need for detailed analysis in the management of agricultural enterprises.

In order to make the most correct decision that will best meet the goals of the company, and have a minimum share of risk, you need to take into account all existing risks and optimize the decision-making process [7].

Support for management decisions in the enterprise should be provided by a set of methods and models (Figure 4).

The first analytical tool to support management decisions is the indicator method, based on the use of which as a result of comparing the actual performance of the enterprise with indicators, you can choose the

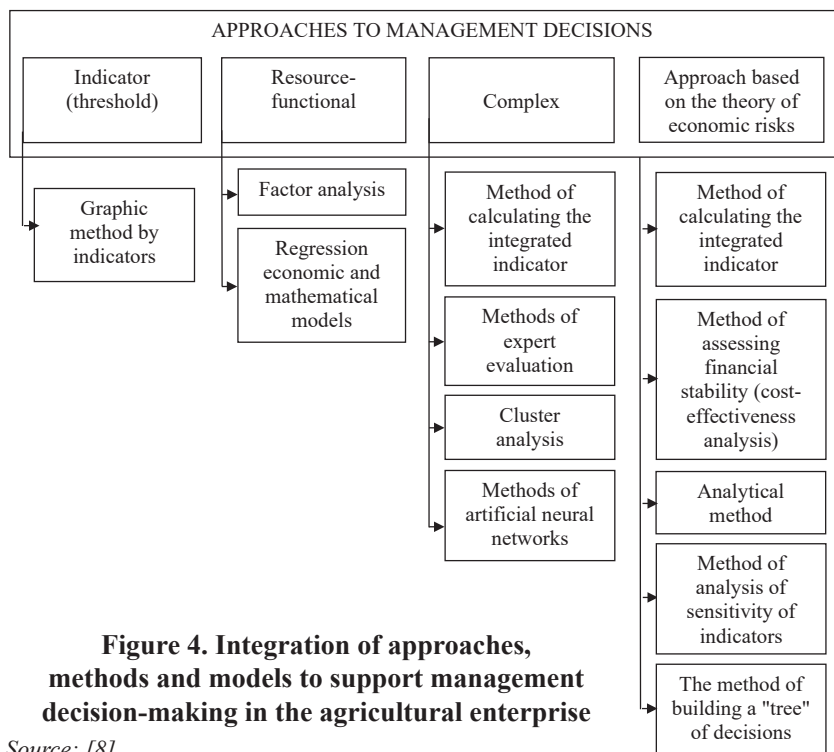

Figure 4. Integration of approaches, methods and models to support management decision-making in the agricultural enterprise

Source: [8]

optimal management solution based on approximation or distance of actual performance from indicators in the dynamic aspect.

The resource-functional approach integrates such analytical tools as factor analysis and regression economic-mathematical models. The use of stochastic factor analysis allows for the identification of latent factors. Enterprise managers must take into account the identified factors when making key management decisions.

A complex approach to support management decisions combines the method of calculating the integrated indicator, methods of expert evaluation, cluster analysis, methods of artificial neural networks. For example, when using cluster analysis, the person who makes management decisions understands what level the company has in the set of other analyzed enterprises.

When using the approach based on the theory of economic risks for management decisions, it is advisable to use the statistical method, the method of assessing financial stability, the method of analyzing the sensitivity of indicators, and the method of building a “tree” of decisions. We consider the construction of a “tree” of decisions to be the most optimal method of supporting management decisions at the enterprise.

The most important feature of modern analytical research is their strategic orientation, which involves a comprehensive study of the internal economic processes of the enterprise with an assessment of the impact of environmental factors. First of all, the factors of the external environment are studied, their possible impact on the development of the enterprise is studied, the optimal ways to achieve the targets are determined taking into account the need, in particular adaptation to the external environment and impact on the external environment [4].

3. The role of information software in the analysis

In conditions of high competition and European integration, analytical information has become a creative type of management activity, which is a necessary condition for civilized relations in business and serves as a basis for sound strategic management decisions at all levels of management.

It is impossible to evaluate the financial and economic activity of the enterprise by any one indicator. The variety of properties and characteristics of different types of production – economic and commercial activities of

LLC “Kurland” determines the variety of indicators. The problem with their use is that none of them serves as a universal indicator by which one could unequivocally judge the achievements or failures of the business. Therefore, the company in practice always uses a system of indicators that are interrelated, evaluate or show different areas of the enterprise.

A systematic approach to the analysis of economic phenomena and processes is expressed in a comprehensive study of interrelated, multilateral economic, organizational, technical, and technological factors in the application of the system of indicators [6].

The system of indicators that reflects the activities of the enterprise is a set of interrelated values that comprehensively characterize the property and financial condition, its activities, and the results of these activities.

The main economic indicators of LLC “Kurland” are presented in Table 1.

During the period under review, there were no changes in the size of land, and the value of marketable products increased by 35945 thousand UAH and in 2020 amounted to 327233 thousand UAH, which indicates an increase in production by the company, but also the impact of inflation, as compared to 2019 there is a decrease of 35133 thousand UAH. The average annual number of employees in 2020 compared to 2018 as a whole increased by 12 people. A decrease in productivity and return on capital by 245687 UAH and 0,81 UAH indicates the inefficient use of labor and fixed assets compared to 2019. The average annual value of fixed assets in 2018 amounted to 93050 thousand UAH, and in 2020 increased by 51,2% and amounted to 140685 thousand UAH, which indicates a significant impact of inflation and a slight renewal of the company’s outdated material and technical base.

Negative should be considered a decrease in net profit compared to 2018 by 86001 thousand UAH, although positive is the profit during 2018-2019. Such an effective indicator as net income (revenue) from sales increased by 35945 thousand UAH, and gross profit – on the contrary, decreased by 19941 thousand UAH and 46643 thousand UAH in accordance.

Growth of direct investments in the economy of LLC “Kurland” by 51672 thousand UAH relative to 2018 indicates its investment attractiveness.

The value of the coefficient of the attractiveness of product >1 characterizes the competitiveness of products produced by the company, but the negative phenomenon is its decrease compared to 2018 and 2019.

Table 1

**The main economic indicators of resources and performance
LLC “Kurland”**

Indicator	2018	2019	2020	Deviation of the reporting year (+,-)	
				from the base year	from the intermediate year
1	2	3	4	5	6
Agricultural area lands, ha	10593	10593	10593	-	-
incl. arable land area, ha	10593	10593	10593	-	-
The average annual number of employees, pers.	64	65	76	12	11
The average annual cost of fixed assets, thousand UAH	93050	99966,5	140685	47635	40718,5
incl. machinery and equipment, thousand UAH	63168,5	74839	107272,5	44104	32433,5
vehicles, thousand UAH	5674,5	6371,5	12675,5	7001	6304
Net income from sales of products (goods, works, services), thousand UAH	291288	362366	327233	35945	- 35133
Gross profit, thousand UAH	25680	52382	5739	- 19941	- 46643
Net profit, thousand UAH	77731	77466	- 8270	- 86001	- 85736
Labor productivity, UAH	4551375	5574861	4305697	- 245678	- 1269164
Return on assets, UAH	3,13	3,62	2,32	- 0,81	- 1,3
Investment income, thousand UAH	18354	1261	70026	51672	68765
Coefficient of attractiveness of goods (net revenue / cost)	1,096	1,169	1,018	- 0,078	- 0,151

Source: calculated by the author according to the studied company

The main purpose of developing the company's production program is to form the optimal ratio between industries and types of agricultural products, which allows achieving high financial results with maximum use of resource potential of the enterprise and its market opportunities.

The production program is measured in physical and cost measures. Natural indicators include production volumes, sales volume in quintals, tons, heads. The volume of production in value terms in agricultural enterprises is determined by the indicators of gross output at constant prices in 2016, gross output at current prices, marketable products (Table 2).

These tables show that LLC "Kurland" is not engaged in the production of livestock products. At the end of 2020, there is a decrease in production for almost all types of products, except wheat and sunflower. Sales increased only by barley by 4973 quintals and sunflower by 53491 quintals. At the end of 2020, the level of marketability decreased for almost all types of products, except for sunflower seeds, the production of which is economically profitable for the company.

Financial diagnostics is one of the main elements of the financial policy of the enterprise. Carrying out a comparative analytical balance of the enterprise leads to significant real results of the financial condition of the enterprise. In turn, the financial condition is a leading factor in the competitiveness and sustainable development of the enterprise and the core characteristics of the firm in market conditions [9].

In the conditions of modern expansion of competition for maintenance of a stable financial condition of the enterprises, there is a necessity in carrying out the analysis of indicators of liquidity of balance. Liquidity is defined as the ability of certain types of property to quickly turn into cash without losing their current value in today's market conditions.

Balance sheet liquidity analysis is a comparison of asset items grouped by liquidity and arranged in descending order with liability items grouped by maturity and placed in ascending order of maturity. To determine the liquidity of the balance sheet groups of assets and liabilities are compared [9; 10] (Table 3).

Liquidity analysis of the balance sheet of LLC "Kurland" for 2019–2020 showed that throughout the period the balance sheet of the company as a whole is illiquid, namely at the end of the reporting period:

Table 2
**Analysis of the production program and the level of marketability
of the main types of agricultural products of the enterprise**

Types of products	2019			2020			Відхилення, (+,-)		
	Production, q	Realization, q	Level of marketability, %	Production, q	Realization, q	Level of marketability, %	Production, q	Realization, q	Level of marketability, %
wheat	111270	112793	101,4	115772	103998	89,8	4502	- 8795	- 11,6
corn on the cob	303040	437857	144,5	221531	232380	104,9	- 81509	- 205477	- 39,6
barley	250	250	100	5638	5223	92,6	5388	4973	- 7,4
soybeans	32690	54312	166,1	12052	15110	125,4	- 20638	- 39202	- 40,7
rapeseed	64830	65116	100,4	19148	19020	99,3	- 45682	- 46096	- 1,1
sunflower seeds	74040	68983	93,2	117735	122474	104,0	43695	53491	10,8

Source: calculated by the author according to the studied company

Table 3

Balance sheet liquidity analysis, thousand UAH

Assets	At the beginning of the reporting period	At the end of the reporting period	Liabilities	At the beginning of the reporting period	At the end of the reporting period	Payment surplus or shortage	
						At the beginning of the reporting period	At the end of the reporting period
1	2	3	4	5	6	7	8
The most liquid assets (A1)	48828	6466	Immediate liabilities (L1)	38270	136925	10558	- 130459
Fast-moving assets (A2)	168292	248199	Short-term liabilities (L2)	515642	500063	- 347350	- 251864
Slow-moving assets (A3)	106920	148535	Long-term liabilities (L3)	62982	99030	43938	49505
Hard-to-sell assets (A4)	180104	258812	Permanent liabilities (L4)	- 112750	- 74006	292854	332818
Balance	504144	662012	Balance	504144	662012	-	-

Source: calculated by the author according to the studied company

– $A1 < L1$, which indicates that for two years the company does not have enough of the most liquid assets to cover the most urgent liabilities, ie the liquidity of the balance sheet is not absolute;

– $A2 < L2$ – assets that are quickly realized less short-term liabilities. This means that the company will not be able to settle with creditors after receiving cash from the sale of its products;

– $A3 > L3$ – this means that the company fully covered long-term liabilities, which had a positive impact on the solvency of the company;

– $A4 > L4$ – the company does not comply with the minimum conditions of financial stability – the availability of working capital. Based on this, we can judge the financial instability of LLC “Kurland”.

So, the analysis of the liquidity of the balance sheet of the company just allows you to identify the most important aspects and weaknesses in its activities and shows in which areas you need to carry out such work in order to improve financial condition.

Analysis of the stability of the financial condition on a given date allows us to answer the question: how well the company managed financial resources during the period preceding that date. It is important that the state of financial resources meets the requirements of the market and the needs of enterprise development, as insufficient financial stability can lead to insolvency of the enterprise and lack of funds for product development, and excess – hinder development, complicating the company’s costs with excess reserves.

Financial stability is a state of financial resources of the enterprise, in which the rational disposal of them is a guarantee of the availability of own funds, stable profitability, and ensuring the process of expanded reproduction. Financial stability is one of the main factors influencing the achievement of financial balance and financial stability [11; 12].

Let’s analyze financial stability in Table 4.

Analyzing the data in Table 4, we can say that this company during 2018–2020 is characterized by a critical level of financial independence, which has changed slightly over the past 3 years and is due to the high level of retained earnings of previous years, due to which LLC “Kurland” has a negative capital. During 2018, LLC did not use long-term borrowings, and only in 2019 and 2020 the company has other long-term liabilities.

**Analysis of indicators of financial stability and solvency
LLC “Kurland”**

№	Indicators	2018	2019	2020	Deviation, (+,-)
1	2	3	4	5	6
1.	Coefficient of financial autonomy	- 0,223	- 0,231	- 0,119	0,104
2.	Coefficient of financial stability	- 0,182	-0,106	- 0,106	0,076
3.	Coefficient of financial dependence	- 4,48	- 4,32	- 8,41	-3,93
4.	Funding ratio	- 5,48	- 4,78	- 9,41	- 3,93
5.	Long-term capital ratio	-	- 1,17	4,87	4,87
6.	Availability of working capital, thousand UAH	-204699	-233819	- 238477	- 33778
7.	Equity maneuverability ratio	2,06	2,0	3,03	0,97
8.	Absolute liquidity ratio (solvency)	0,0037	0,0875	0,0101	0,0064
9.	Rapid liquidity ratio	0,4118	0,3892	0,3998	- 0,012
10.	Current ratio	0,6279	0,5809	0,6329	0,005

Source: calculated by the author according to the studied company

A positive factor is an increase in the funding ratio of LLC “Kurland” over the last 3 years, albeit with a negative value. As a result of the presence of equity in the LLC, there is a negative value of working capital, and the dynamics of this amount have increased. Thus, at the end of 2020 LLC has a shortage of its own sources of working capital in the amount of 238477 thousand UAH, which is 33778 thousand UAH less than the base year level.

The coefficient of maneuverability of equity shows what part of working capital is in circulation, ie in the form that allows free maneuvering of these funds, and which is capitalized. To ensure flexibility in the use of the company’s own funds, it is necessary that the coefficient of maneuverability in its value was high enough.

A separate group consists of solvency ratios. Solvency is the ability of an enterprise to repay its liabilities in a timely manner with cash and assets.

Among the analyzed indicators in LLC “Kurland” during the period under study increased the level of ratios of monetary and liquid solvency. In 2020, the value of the solvency ratio increased slightly due to an increase in the company’s cash by 0,0064 points, but much lower than the recommended

level (0,2-0,25). At the same time, the estimated and liquid solvency also remain quite low and do not reach the recommended value.

In general, it is possible to state the unstable financial condition of the company.

In the process of establishing the loss of financial stability and solvency of the enterprise, there are two directions: the system of financial rapid diagnostics and fundamental diagnosis of financial condition. Express diagnostics is a system of regular assessment of crisis parameters of financial development of the enterprise, carried out on the basis of financial accounting data according to standard algorithms of analysis, in order to early identify negative trends and pre-assess the scale of its crisis.

The management of LLC “Kurland” needs to take possible measures to improve financial and economic activities. To this end, it is advisable to conduct continuous monitoring and operational analysis of financial stability and solvency.

In the context of European integration processes, domestic enterprises face a number of issues that need to be harmonized with the world practice of business management. One of such questions is the analysis of the business activity of the enterprise for the purpose of acceptance of the considered operative administrative decisions and formation of strategy for the future.

Business activity in modern business conditions is a decisive factor in commercial success. At the same time, business activity is a defining characteristic of the company’s position in the market [13].

The main indicators of business activity of LLC “Kurland” are given in Table 5.

Table 5 data show that in the reporting year the level of business activity of the company slightly deteriorated. The main reason for this is the deterioration of the company’s position in the relevant market segment. Accounts receivable at the end of 2020 increased by 76774 thousand UAH, which is a negative phenomenon in the activities of LLC “Kurland” due to the increase in receivables for goods, works and services, and other types of receivables.

LLC “Kurland” also increased the receipt of long-term and short-term loans by 48191 thousand UAH and 195942 thousand UAH in accordance. The decrease in turnover and productivity negatively affected the state of business activity of the company, and the decrease in the average term of

Analysis of business activity of LLC “Kurland”

№	Indicators	2018	2019	2020	Deviation, (+,-)
1.	Total capital turnover ratio	0,75	0,76	0,56	- 0,19
2.	Mobile turnover ratio	1,01	1,09	0,89	- 0,12
3.	Turnover ratio of tangible working capital	2,55	3,94	5,78	3,23
4.	Turnover ratio of finished products	4,03	7,16	24,58	20,55
5.	Receivables turnover ratio	12,58	34,86	19,58	7
6.	Average term of turnover of receivables, days	29,01	10,33	18,39	- 10,62
7.	Accounts payable turnover ratio	1,48	55,44	63,69	62,21
8.	The average term of turnover of accounts payable, days	243,2	6,49	5,65	- 237,55
9.	Return on fixed assets and other non-current assets	3,13	3,62	1,49	- 1,64
10.	Equity turnover ratio	-	-	-	-
11	Labor productivity, thousand UAH	4551375	5574861	4305697	- 245678

Source: calculated by the author according to the studied company

turnover of receivables and payables – on the contrary, has a positive effect on the financial condition of the company.

No less important is the analysis of profitability indicators. Profitability shows how profitable the company is. Accordingly, the higher the profitability ratios – the more efficient the company. Therefore, today, the company should strive to achieve higher performance, and management should identify ways to grow [14].

Next, we examine the profitability indicators on the example of the studied company (Table 6).

As can be seen from the above calculations, the profitability of LLC “Kurland” for the period under review is declining in almost all indicators, except the return on equity, as the amount of equity is negative. The presence

Table 6

Analysis of profitability indicators of the enterprise, %

Indicators	2018	2019	2020	Deviation, (+,-)
1. Return on assets	20,09	16,32	- 2,27	- 22,36
2. Return on share capital	- 51,61	- 71,75	8,46	60,07
3. Return on fixed assets	83,54	77,49	- 5,88	- 89,42
4. Profitability of the main activity	26,68	21,38	- 2,57	- 29,25
5. Product profitability	109,67	116,89	1,78	- 107,89
6. Profitability of sales	8,82	14,45	1,75	- 7,07

Source: calculated by the author according to the studied company

of undistributed loss affected the value of return on equity. During the study period, there is a decrease in management efficiency.

Summing up, we note that the calculated profitability indicators are only indicative, as the information base for their calculation was limited to financial statements, which in this case is insufficient. For a more detailed calculation of profitability indicators, information from the registers of financial, management, and strategic accounting is needed. In the case of an increase in production, you can expect an increase in profitability.

4. Findings

The analysis is the link between information flows of the enterprise and management decisions. However, not all streams are an information base, as they may be heterogeneous in form and content. In order for information flows to be linked, they must be pre-processed. In order for the information flow to become the information base of the analysis, it must be transformed and processed. Preparation of information necessary for the implementation of the analysis includes several stages: a collection of primary data, their processing, and presentation. Only then is the data transformed into information suitable for management decisions.

We believe that the information need of managers is a form of attitude to certain information, which qualifies as necessary to solve the problem. The main objective factors influencing the formation of information needs of managers are the type of management activities, features of the functions performed related to different levels of management activities in the economic system.

Adequate assessment of the events taking place and the validity of the planned management decisions depend on the completeness of the information base and the reliability of the information support. In order to formulate conclusions based on the results of the analysis, to substantiate on their basis management decisions aimed at improving the efficiency of business and financial and economic activities of enterprises, it is extremely important for professionals to develop adequate measures [15].

To do this, it is necessary to develop the structure and improve organizational regulations:

- organization of analytical service and coordination of work of persons engaged in analysis;
- conducting analytical work (Figure 5).

The following factors should be taken into account when developing a system of internal regulations for the organization and conduct of the analysis:

- organizational and legal form of the enterprise;
- management structure;
- the specifics of the enterprise;
- the size of the enterprise and the volume of activity;
- taxation system.

That is, developing or improving the system of internal regulations should be based on the provisions of the company's charter, regulations on branches (structural units, departments), regulations on governing bodies, regulations on the organization of accounting and accounting policies, etc.

The main organizational regulations, on the basis of which the methodological guidance, organization, and conduct of economic analysis at the enterprise, should be the Regulations on the analysis department. Since the current regulations do not impose any mandatory requirements for this Regulation, based on the functional purpose, in our opinion, the Regulation on the Department of Economic Analysis should consist of the following main sections: general provisions; the organizational structure; tasks, and functions; rights; responsibility; relationships with other departments (services, units); final provisions (Table 7).

This Regulation must be approved in the manner prescribed by the company's charter and brought to the attention of employees who are directly related to the tasks provided for in it.

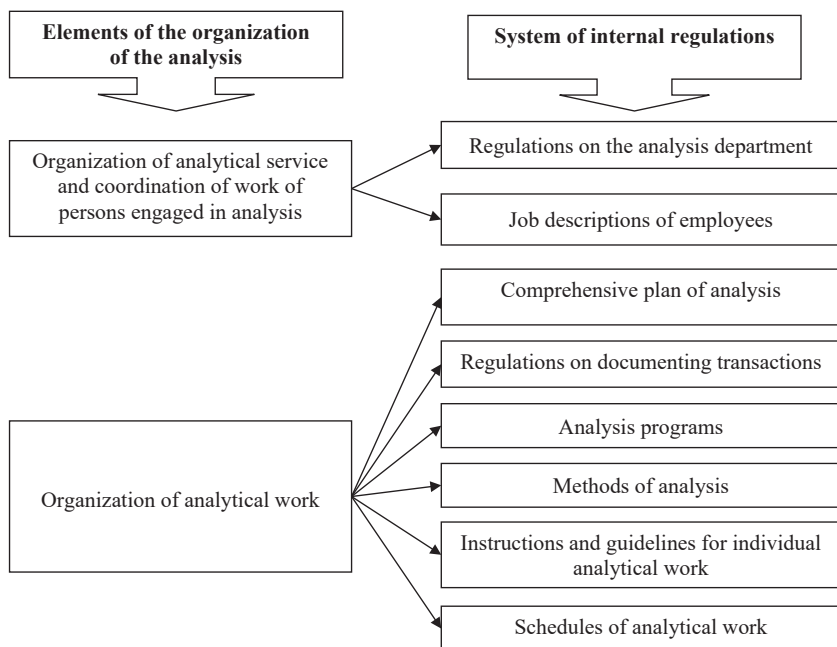

Figure 5. The structure of the regulatory analysis

Source: suggested by the author

The development and implementation of such Regulations promote, first of all, a clear division of labor between departments and within the department and creates a regulatory framework for disciplinary and material influence on employees who violate the rules of the relevant work.

At all levels of management, LLC “Kurland” requires an official responsible for planning, coordinating, organizing, and conducting analysis at this level of management, as well as for providing timely and necessary information to those who are interested in this information making management decisions. The appointment of such an official depends on the structure and size of the management of the company as a whole, as well as on the form of organization of the analysis. Coordination of contractors should ensure both vertical and horizontal division of responsibilities. Lower levels of management form a large number of indicators, which

Structure of the Regulations on the analytical department

Section name	Summary
Terms	Determine the legal status of the department and its place in the enterprise management system. The main purpose for which the department is created (organization and analysis of the economic activity of the enterprise) is outlined
The organizational structure	Structural subdivisions, department management, etc. are noted
Tasks and functions	Highlight the main tasks and functions that fall within the competence of the department with their respective correspondence for the purpose of the department
Rights	Determine the rights granted to the department
Responsibility	Define the limits of responsibility of the department
Relationships with other departments	Indicate the direct and indirect connections of the department or the relevant department in the department with others
Final provisions	Determine under what circumstances and in what order the expansion, reorganization or liquidation of the department takes place; to whom powers are transferred after liquidation, etc.

Source: suggested by the author

should be grouped at higher levels and received by direct users in an appropriate form (should not be overloaded with unnecessary data, but at the same time reflect all the necessary indicators). That is, the horizontal coordination of analytical work should provide a ratio: the lower the level of management, the more indicators it forms according to the results of the analysis, and the higher the level of management, the fewer indicators it receives. Vertical coordination of works is provided by the uniform plan of works for all executors and has to eliminate duplication of indicators by various functional services and divisions.

That is why special attention should be paid to the organizational structure of the enterprise as a whole and the analytical department in particular. The organizational structure of the analysis department determines the scheme of orders and directives by which the activities of the department are planned, organized, and controlled, as well as provides the company with an appropriate basis for the organization and performance of other work.

The development of the organizational structure of the department will ensure the effective organization and coordination of the work of those involved in the analysis. Thus, improving the organizational structure, you can improve the performance of analytical work.

On the one hand, the organizational structure of the department ensures the economic efficiency of its activities, on the other hand, maintains the morale and staff job satisfaction.

Coordination of workers' work also depends on the organization of work, ie on how many people's work activities are reduced to a system that can ensure the achievement of the maximum possible beneficial effect, given the specific conditions of this activity and the level of responsibility.

Equally important in organizational support is individual organizational regulations, such as job descriptions, which ensure a clear division of responsibilities between employees.

Job descriptions are developed for each full-time position, approved by the head of the company, and communicated to the employee against a receipt. It reveals the main tasks, functional responsibilities, rights, and responsibilities for the performance of functions assigned to the employee.

Job descriptions may be amended and supplemented only on the basis of the internal order of the head of the company with the consent of the employee. The relevant order on changes and additions to the job description is also issued in case of reorganization of the management structure of the enterprise, redistribution of responsibilities between employees in connection with the reduction of staff, etc. All job descriptions developed at enterprises must be interconnected to avoid duplication of work.

Regulations on the department and job descriptions regulate the structural side of the organization of analysis in the enterprise. If the analysis will be carried out with the involvement of external specialists, auditing, or consulting firms, then, accordingly, such regulations are not developed at the enterprise. And certain responsibilities for operational analysis are set out in the job descriptions of employees of accounting or other departments or divisions of the company.

A feature of the formation of input information used in the analysis is its diversity. After all, such information comes from many sources, differs in its frequency of receipt and calculation technique [4]. Directly in the process of analysis own documents are created. Processing of input and

creation of analytical data is associated with a large number of operations and the involvement of a certain range of performers, which requires a pre-designed system of their actions and procedures for moving information (documents) both in space and time.

One of the features of the analysis is that it provides information to both the administrative-economic and production departments of the enterprise. Therefore, employees engaged in economic analysis are morally and materially responsible for the results of the analysis. In this context, the moral responsibility of employees is to adhere to the professional ethics and competence of the analyst.

The financial responsibility of the analyst should be regulated by job descriptions and employment contracts and include penalties or dismissals for improper performance of professional duties.

Today, inside information about the company is of great value to competitors. Therefore, the analyst should be warned about disciplinary, civil, administrative, and criminal liability under Ukrainian law for disclosing confidential analytical information.

Despite all the organization and regulation of analytical work in the work of the analyst may be unusual situations that require prompt response. In these situations, the analyst is forced to apply analytical procedures at its discretion, without coordinating them with the head. Based on this, the work of analysts should be based on the principles of self-organization and training [2].

One of the important tasks is to develop and improve the rules of analysis, which should reflect the following provisions:

- organization of the analytical process (standardization of analytical tasks, etc.);
- organization of work of functional subdivisions of the management staff, responsibilities of employees of each level of management, to carry out analytical work;
- frequency of analysis (retrospective, operational, long-term, strategic).

Processing of documents and data in the analytical process is to convert input information into output by conducting analytical procedures that can be performed manually or using computer technology.

The development of working documentation on the analysis also involves the development of documents for drawing conclusions. At each stage of

the analytical process, there are special documents (information carriers), which are most characteristic of the stage and depend on the characteristics and specifics of the enterprise. At the preparatory stage, along with external documents (primary documents, consolidated accounting records, etc.), analytical tables are formed for the accumulation and verification of external information. At the main stage of the analytical study using spreadsheets.

The results of the analysis at the final stage are made out depending on the purpose and on the volume of research. Documents that reflect the results of the analysis are divided into two types: 1) text (descriptive), which includes conclusions, analytical notes, reports, and others; 2) without text – tables, graphs, charts, etc. This direction of improving the organizational support will determine the efficiency of obtaining the results of the analysis and at the same time the feasibility of its implementation [4; 13].

The identified areas of improvement of organizational support for the analysis of economic activity are closely interrelated, interdependent, and complementary. Therefore, their implementation should be carried out in a complex, taking into account the characteristics of each enterprise, its management structure, and activities.

Improving the organizational support of the analysis involves its planning. When planning the analysis, it is necessary to proceed from the fact that for its quality implementation it is necessary not only to determine the responsible executors but also to organize and coordinate the work of all services. It is also advisable to take into account the quality of organizational, methodological, personnel, logistical support of the analysis. However, it is necessary to provide for the improvement of the analysis system, analytical media, the introduction of new methods, and more.

Analysis planning should be carried out in three main areas: organizational activities, areas (types) of analysis, improvement, and development of analysis.

The peculiarity of agricultural production is that the main means of production are land resources and biological assets. Therefore, the activities of agricultural enterprises are significantly influenced by natural and climatic factors.

Taking into account the peculiarities of agriculture in the formation of analytical information allows a comprehensive assessment of economic and social results, to develop the number and quality of performance indicators.

It is worth noting the unique ability of digital technologies to positively affect the economic efficiency of agricultural enterprises, the effectiveness of modern forms of business organization, a real opportunity to search, process, analyze and transmit information; ensuring the creation of competitive advantages of domestic agricultural producers.

The global pandemic has demonstrated digital opportunities to change the nature of employment. Remote work with the use of information technology has become an important tool for transforming the use of human capital [16].

By forming and grouping analytical information obtained through digitization technologies and digital development tools, executives at both the macro and macro levels receive data for retrospective analysis, planning, and forecasting. In the context of globalization, digital technologies are both a huge market and an industry as a whole, as well as a platform to ensure the efficiency and competitiveness of other markets and industries.

The obtained set of available data in the process of digitization of all types and spheres of business activity will allow to carry out constant analysis of ecological and economic development of the enterprise – at the micro-level and the state as a whole – at the macro level, balanced, scientifically sound approach to the implementation of the intended goal.

The formed management decisions on actual, reliable, and real data will promote planning of the expected result taking into account probable risks which will be foreseen, estimated, and minimized [17]. Development of strategy and formation of step-by-step (tactical and operational) plans will help reduce the impact of risks and improve the definition of conditions for the implementation of the planned strategy.

5. Conclusions

Thus, the considered integration of approaches, methods, and models will increase the rationality of management decisions by adjusting the probability of occurrence of an event and selecting among the alternatives the best project on the criterion of profit maximization. The next stages of research will be based on scientific substantiation and development of practical recommendations for all developed analytical tools to support management decision-making in agricultural enterprises.

The system of analytical information is an important element of management, which helps to identify weaknesses in the activities of enterprises and develop the right management decisions to ensure stable operation and create conditions for the growth of the economic potential of economic entities.

From the standpoint of analysis of the financial and economic condition of LLC “Kurland”, it should be noted about the use of management systems and, accordingly, the processing of information data. Implementation of the management system and timely data processing allowed the company to achieve positive changes in the results and to form growth trends, organize the work of structural units, the main activities, to achieve the economic effect. That is, the researched company constantly analyzes, collects, processes information and transfers it to functional units for decision-making, but to more accurately identify problems in its operation and features of data use, it is advisable to analyze the state of information support and its impact on management, which will determine the feasibility of improving analytical information.

The specifics of the activities of agricultural enterprises requires a separate method of analysis, taking into account the peculiarities of their operation.

The developed organizational and methodological mechanism of analytical support of the enterprise includes the procedure, methods, and information support for calculating the indicators of production, social and environmental components of the enterprise, financial condition, and risk appetite. Building a system of indicators according to the proposed methodology and their generalization in the analytical report will ensure the complexity and systematicity of analytical research, will help to obtain reliable, complete, and operational analytical conclusions, which, in turn, will allow effective management decisions.

By forming and grouping analytical information obtained through digitization technologies and digital development tools, executives at both the macro and macro levels receive data for retrospective analysis, planning, and forecasting. In the context of globalization, digital technologies are both a huge market and an industry as a whole, as well as a platform to ensure the efficiency and competitiveness of other markets and industries.

References:

1. Litvin, Z. B., & Seredinskaya, V. M. (2019). Analysis as an integral tool of efficiency in the enterprise management system. Retrieved from: <http://dspace.wunu.edu.ua/jspui/bitstream/316497/37234/1>
2. Mulyk, T. O. (2020). Organizational and methodological aspects of the analytical service of the enterprise. Retrieved from: http://www.economy.nayka.com.ua/pdf/8_2020/74.pdf. DOI: 10.32702/2307-2105-2020.8.72.
3. Stetsyuk, L. S. (2016). Organization of analytical work on agricultural enterprises. Retrieved from: <http://magazine.faa.org.ua/organizaciya-analitichnoi-roboti-na-silskogospodarskih-pidpriemstvah.html>
4. Tomchuk, O. F. (2020). Analytical support of agricultural enterprises and its improvement. *East European Scientific Journal*, no. 3(55), pp. 54–66.
5. Tomchuk, O. F. (2019). Theoretical aspects of the analytical support system. *Market infrastructure*, no. 35, pp. 484–492. DOI: <https://doi.org/10.32843/infrastructure35-76>
6. Mishchuk, G. Yu., Dzhigar, T. M., & Shishkina, O. O. (2017). Economic analysis: textbook manual. Rivne: NUVGP, 156 p.
7. Vikhlyaeva, S. I., & Fedyai, V. I. (2013). Ways to optimize management decisions of the enterprise in conditions of risk and uncertainty. *Bulletin of NTU «KhPI»*, no. 67 (1040), pp. 143–147.
8. Ivashchenko, G. A., & Skripay, A. S. (2015). Information and analytical support of management decisions at the enterprise. *Economic analysis*, vol. 21, pp. 86–92.
9. Mazur, V. A., Tomchuk, O. F., & Branitsky, Yu. Yu. (2017). Methods of analysis of the financial condition of the enterprise in accordance with the requirements of internal and external users. *Economy. Finances. Management: current issues of science and practice*, no. 3(19), pp. 7–20.
10. Tomchuk, O. F. (2018). Analytical capabilities of the balance sheet (statement of financial position) of the enterprise. *Black Sea Economic Studies*, vol. 28, ch. 2, pp. 152–159.
11. Mulyk T., Tomchuk O., & Fedoryshyna L. (2020). Analysis of financial stability of the enterprise. *The scientific heritage*, no. 43, pp. 46–55.
12. Tomchuk, O. F. (2020). The role of financial stability in the assessment of the enterprise bankruptcy. *Slovak international scientific journal*, no. 38, pp. 14–24.
13. Tomchuk, O. F. (2016). Analytical support of business activity management of the enterprise. *Global and national economic problems*, issue 10, pp. 991–995.
14. Farion, V. Ya. (2019). Analytical assessment of business activity and profitability of enterprises. *Innovative economy*, no. 10, pp. 27–33.
15. Putsenteilo, P., & Humeniuk, O. (2019). Information support of analytical activities in enterprise management. *Institute of Accounting, Control and Analysis in the context of globalization*, issue 1-2, pp. 74–82. DOI: <https://doi.org/10.35774/ibo2019.01.074>
16. Samoilenko, A. (2021). Features of digitalization of the European Union in the context of globalization. *Herald of Economics*, no. 1, pp. 46–54. DOI: <https://doi.org/10.35774/visnyk2021.01.046>
17. Kaletnik, G. M., Gunko, I. V. (2017). Innovative platforms for the organization of research and discussion youth platforms in the context of European integration development of the agricultural economy. *Economics, finance, management: current issues of science and practice*, no. 4, pp. 7–18.

**ORGANIZATIONAL AND ECONOMIC MECHANISM
OF INCREASING THE COMPETITIVENESS
OF AGRICULTURAL ENTERPRISES**

Olha Khaietska¹

DOI: <https://doi.org/10.30525/978-9934-26-193-0-13>

Abstract. The article analyzes the organizational and economic principles of functioning of agro-industrial enterprises, explores the possibilities of increasing their competitiveness. In particular, it is noted that the category of “organizational and economic mechanism” is the most important part of the economic system, including in the agricultural sector. The essence, content and adjustment of the organizational and economic mechanism is determined by many scientists and researchers, the focus is on industrial relations and economic laws. It is important to understand the levers of organizational and economic mechanism (economic and organizational). Economic factors include: the mechanism of market pricing; levers for investing and lending bonds, financing; self-financing of investments; accumulation and investment of capital, state regulation and state support. Organizational factors include: structural levers; organizational and technical levers; levers of management organization; corporate planning and information levers. Using the levers of self-sufficiency, the peculiarities of the activities of agar enterprises in the domestic and foreign food markets are manifested to obtain the most attractive effect with minimal costs.

An important component of economic efficiency of agricultural enterprises is the maintenance of competitive conditions as a stimulus for the rational functioning of enterprises and organizations. Pure competition is an incentive for society to minimize costs and maximize profits, as well as adhere to marginal productivity. Competition is best manifested in terms of economic dynamics. Competition increases supply, improves product quality, improves service and availability, and reduces production costs.

¹ Candidate of Economic Sciences, Associate Professor,
Head of the Department of Economics and Entrepreneurship,
Vinnytsia National Agrarian University, Ukraine

The article analyzes the views of economists on the category of “competitiveness”, provides indicators of competitiveness (price, market and quality indicators), the structure of the mechanism for improving the competitiveness of agricultural enterprises, proposed methods for assessing the competitiveness of enterprises and effective management of enterprise competitiveness. It is noted that the competitiveness of production in the agro-industrial sector depends on resource supply, infrastructure development, the level of development of labor resources, the external environment, which is based on state policy on its development and more. To increase the competitiveness of enterprises should have competitive advantages: to improve their activities and increase their efficiency, to influence the market environment, to ensure the maximum possible result for each unit of labor, material and financial resources spent.

Therefore, for the effective functioning of agro-industrial enterprises, increasing their competitiveness, it is necessary to apply a complex and effective organizational and economic management system. The main directions of increasing the competitiveness of agricultural enterprises are effective marketing policy, improving quality, service, maintenance, reducing production costs and production costs with maximum benefit in the future, as well as involvement in the production of new technologies, complex mechanization and automation, rational use of means of production and resources involved, etc. The use of these factors will ensure further growth and increase the efficiency of production of agricultural enterprises.

1. Introduction

Organizational and economic mechanism of effective functioning of agricultural enterprises is a system of organizational, economic and legal levers and methods, which together provide a high level of profitability and efficiency. Given the hierarchical levels of government, such a mechanism includes mandatory elements: state and regional governance, development forecasting and planning, incentives, tax and credit policies, product pricing, and cross-sectoral relations. All these elements are interconnected, form a holistic system of influence and ultimately affect the competitiveness of agricultural enterprises.

Organizational and economic mechanism is a set of organizational, economic forms and methods of functioning, interaction and regulation

of elements of economic and managerial decisions aimed at achieving the end result.

The meaning of the category “organizational and economic mechanism” includes certain terms: organizational mechanism and economic mechanism, each category has its own meaning and content and is considered in economics in relation to what process or phenomenon is studied (physical, economic, technical).

Competition is a key concept that expresses the very essence of market relations. The readiness of economic entities to compete depends on the awareness of the nature of competition, forms of its manifestation, methods of competition and the factors that determine the effectiveness of economic entities in such competition.

Competitiveness – a stable position of the country’s producer in domestic and foreign markets, due to economic, social and political factors, its ability to withstand international competition. The purpose of the article is to study the peculiarities of the formation of organizational and economic mechanism and increase the competitiveness of agro-industrial enterprises in modern conditions.

The implementation of a comprehensive assessment of competitiveness should be considered as a set of four interrelated stages: analysis of market conditions; formation of a system of competitiveness criteria; determining the level of competitiveness and developing proposals for its improvement. Competitiveness assessment is a dynamic process that has a cyclical nature and is implemented taking into account the principles, the basic of which are: complexity, system, optimality, relativity, dynamism, information reliability and adequacy of environmental factors and more.

2. The essence and components of the organizational and economic mechanism

Melnyk M. proves that the organizational and economic mechanism is a set of forms and methods through which the organization of social production in it is carried out and its economically expedient activity as a whole is coordinated [10, p. 58].

Considering the organizational and economic mechanism, I. Ponomarek and E. Polyakova note that it is a mechanism for using economic laws, a set of ways and methods of reconciling economic contradictions, combining the

economic interests of society. The authors point out that, «organizational – economic mechanism is inextricably linked with the activities of people and belongs to the sphere of objective economic relations» [13, p. 55].

The structure of the organizational and economic mechanism of the enterprise is shown in Figure 1.

Organizational and economic mechanism is a production relationship in the field of economic and marketing activities that exist between business entities and are based on the law of value and other economic laws under an effective, efficient organizational structure [3, p. 43].

The effectiveness of the organizational and economic mechanism depends on the economic and organizational factors of production, including certain types of services: banking, insurance, investment and innovation, etc.

According to P. Sabluk, the improvement of the organizational and economic mechanism can be carried out through integration into production, cooperation, organization of financial activities and the creation of an effective market infrastructure [16, p. 63].

Thus, the essence of the organizational and economic mechanism can be revealed through a system of organizational, economic determinants, factors, tools that affect the economic activity of subcomplexes, industries, enterprises, which are aimed at achieving the stated goals to increase efficiency.

Organizational and economic mechanism should be considered as part of the economic mechanism and general management. Its essence is a set of ways to influence production processes and businesses to achieve certain development goals. The main components of the organizational and economic mechanism that affect the objects of management are the impact of soil and climatic conditions, product quality requirements, storage and processing conditions, the impact of globalization processes and defined strategic goals of industry development. In each sector of the economy, the organizational and economic mechanism has its differences, so it is important to justify the parameters of influence in order to increase the overall effect to achieve certain development goals.

3. Organizational and economic mechanism in the agricultural sector

Organizational and economic mechanism in the agricultural sector should be considered as a system of organizational, economic, legal,

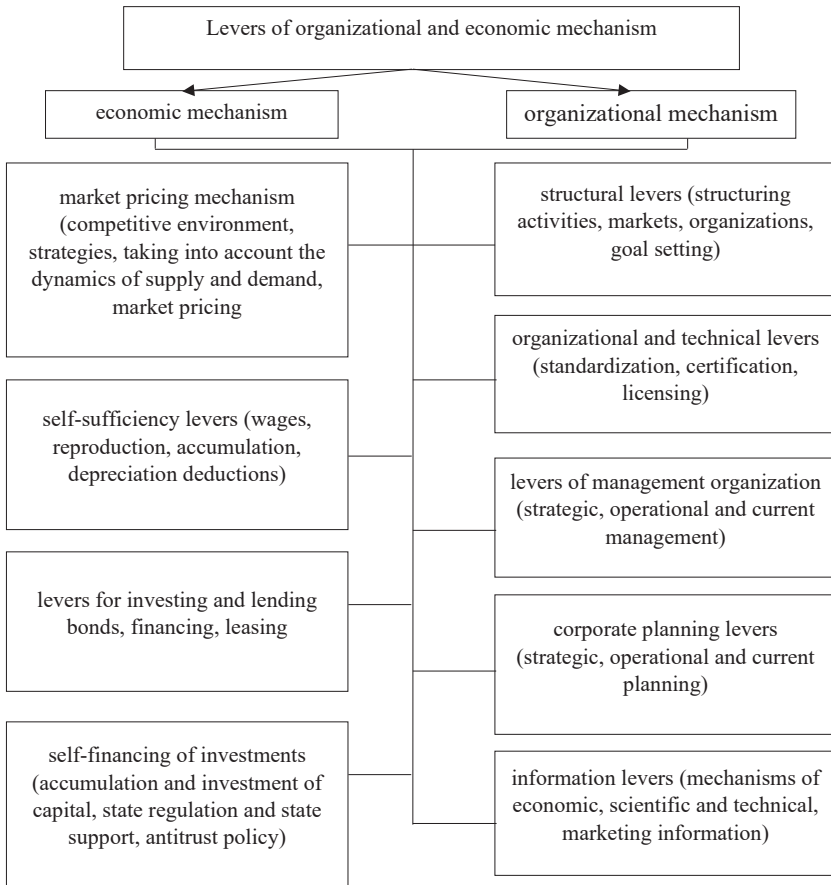

Figure 1. Components of the organizational and economic mechanism

Source: [19]

managerial and regulatory actions, methods and processes that shape and influence the functioning of agricultural enterprises, which will lead to expected economic, social, environmental and other results [10]. “The regulatory mechanism should be considered as a set of organizational and economic methods and tools that perform interrelated functions to

ensure continuous, effective operation of the system (state) to improve the functioning of the economy”.

The agricultural sector is a complex integrated socio-economic system of industries, including enterprises, agricultural formations, institutions belonging to different forms of ownership and different industries. It is necessary to take into account the peculiarity of the agricultural sector that it is a complex biotechnical system. In its central link agriculture uses the most important natural means of production: land, plant and animal organisms, water, light, heat, etc. In this regard, the reproduction of intertwined natural and socio-economic processes. Therefore, the economic mechanism must be extremely flexible, meet not only the requirements of economic but also natural laws. Only on this basis it is possible to ensure the true economic independence of production units located in different climatic and meteorological conditions, as well as flexibly maneuver resources.

The existing management model needs to be transformed, to identify the features of organizational and economic mechanism as an integration concept in market conditions, its impact on production efficiency, ie it is necessary to intensify the development of economic approaches and techniques to improve organizational and economic management mechanism. Reorganization of agricultural enterprises and privatization of land create objective preconditions for improving the domestic economic mechanism, changes in peasant psychology.

The effectiveness of the organizational and economic mechanism of functioning of agricultural enterprises will depend on the optimal choice of tools, levers and the effectiveness of their impact on the functioning of agricultural enterprises. Changing the structural parts, selected tools and levers of influence will automatically cause a change in the organizational and economic mechanism and change the consequences of its action. In addition, it is necessary to take into account the peculiarities of the functioning of agricultural enterprises in the domestic food market. In view of the above, the definition of the organizational and economic mechanism of functioning of agricultural enterprises in the domestic food market is presented in this author's interpretation.

Organizational and economic mechanism of agricultural enterprises in the domestic food market is a set of organizational and economic elements of agricultural enterprises that ensure maximum stability of the enterprise in

the market and obtain maximum results from market activities with minimal costs, which in contrast to the established interpretation of the economic mechanism formation and sale in the system of sales of agricultural products. Consideration of this concept in a broad sense provides a comprehensive study and solution of the problem of functioning of agricultural enterprises in the domestic food market [10].

The formation and development of organizational and economic mechanism have a specific influence on the peculiarities of agriculture as an industry. However, the mechanism should be considered in two directions, objective and subjective. The organizational and economic mechanism of functioning of agricultural enterprises in the domestic food market carries a specific expression of objective laws that are formed at the macro and microeconomic levels. In subjective terms, the organizational and economic mechanism of functioning of agricultural enterprises in the domestic food market can be considered as a system of consciously established forms and methods of organization, management, planning, financing, pricing, incentives, lending, accounting and control. It is formed and implemented at several levels: country, region, district, enterprise, unit.

Thus, the organizational and economic mechanism of agricultural enterprises in the domestic food market is a set of organizational and economic elements of agricultural enterprises that ensure the maximum possible stability of the enterprise in the market and obtain maximum results from market activities with minimal costs. provides for its formation and implementation in the system of marketing of agricultural products. This concept in a broad sense provides a comprehensive study and solution of the problem of the functioning of agricultural enterprises in the domestic food market.

4. Competition as an economic category and incentive for business entities

Limited resources lead to rational behavior of producers, who must choose between competing purposes of their use. At the same time, consumers have a choice between competing uses of money, which forces sellers to compete for consumer money. A. Smith and D. Ricardo noted competition as a competition for profit [2, p. 88].

M. Porter in his work defines competition as a dynamic process that develops; a constantly changing landscape with new products, new marketing methods, new production processes and new market segments [14, p. 88].

J. Schumpeter also made a significant contribution to the development of competition theory, noting that perfect competition for society is an incentive to minimize costs and bring wages as close as possible to its marginal productivity. Effective competition [17] is possible only in conditions of economic dynamics. This state is provided by a qualitatively new level of production, based on the continuous introduction of innovations, innovation at all levels of technology, management and organization of production, product quality, development of new markets, raw materials. Thus, effective competition is a new type of competition based on innovation [15, p. 77].

Competition performs the functions of regulation, motivation, distribution, control. Thanks to the regulatory function, the main factors of production are directed to those areas where there is the greatest need for them and where they can be used with maximum efficiency.

The function of motivation is performed by competition by encouraging business entities to create better quality and lower cost products.

The distribution function is manifested in the fact that profits are redistributed in favor of the most productive production, where the most efficient use of resources. The control function limits the unilateral actions of business entities and gives the consumer a choice.

That is, the competitive mechanism does not allow any of the business entities to manage the market inseparably and dictate their will to consumers. In the theoretical analysis of economic competition, it is important to identify and understand key terms and concepts, including the object, subject and subject of competition (Figure 2).

The importance of competition is manifested in the following features of its impact on the economy [10]:

- Competition forces entrepreneurs to constantly look for and find new products and services.
- Competition promotes the production of high quality products at reasonable prices.
- Competition encourages rapid response to changing customer needs.
- Competition is a powerful alternative to monopoly.

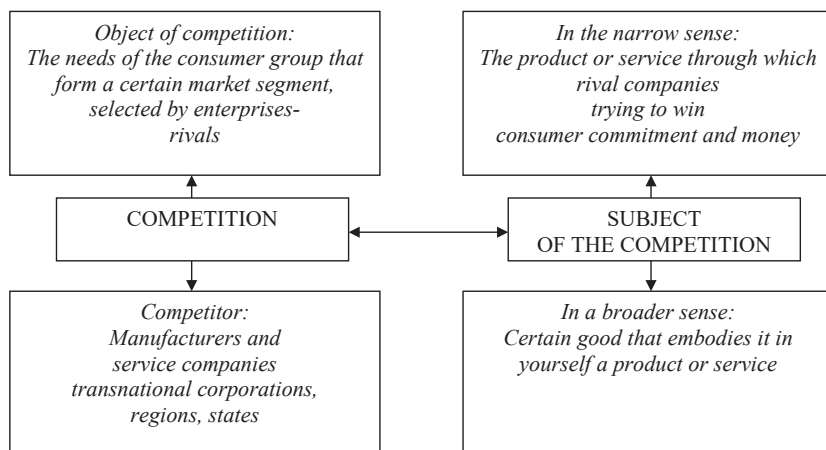

Figure 2. Competition as an economic category

Source: [20]

– Competition promotes the development of technology, science, technology, information systems. Along with the concept of “competition” it is advisable to consider the concept of “competitiveness”.

Competitiveness is manifested only through competition and in appropriate conditions. In market economies, the competitiveness of the enterprise is the result of the interaction of factors resulting from the objective development of productive forces, which are reflected in companies’ policies to improve goods and improve their quality, fight for market share and profit.

Competitiveness is a multifaceted concept that is often used in the practice and theory of economic analysis [25].

The competitiveness of the enterprise means its ability to operate efficiently and ensure profitability in a competitive market. In other words, the competitiveness of the enterprise is its ability to ensure the production and sale of competitive products [25].

The competitiveness of the enterprise is characterized by the ability to provide [26]:

- low production costs;
- uniqueness and features of the offer;

- availability and quality of service;
- eco-orientation of products;
- quality of products (services).

The main approaches to assessing the competitiveness of the enterprise [6]:

– structural, which is based on the decision to adhere to a position in the market. This decision is made by the company based on the level of monopolization of the industry, ie the concentration of production and capital, barriers to new businesses entering the industry market;

– resource, this approach determines the level of competitiveness of the enterprise through the analysis of available resources and efficiency of their use;

– situational – the competitiveness of the enterprise is considered as a process of determining assessments of the effectiveness of market actions in a particular situation in the market;

– target, allows you to consider the analysis of the level of competitiveness of the enterprise as a process of determining estimates that reflect the economic performance of the enterprise in comparison with the relevant targets of competitors;

– quality – based on the study of the competitiveness of enterprise products;

– theory of competitive advantage involves establishing the nature of the company's advantages over competitors and makes it possible to determine the company's position in the market. To characterize competitiveness, the concepts of outstanding scientists are used such as: comparative advantages, comparative costs, comparison of competitive advantages, factors of management and productivity of resource use, competitive status of the firm [9, p. 25].

Modern economists define the concept of “competitiveness” in different ways (Table 1).

At the present stage of development of the agrarian economy, the most important priority of Ukraine's agro-industrial policy should be to increase the competitiveness of domestic producers. This should find comprehensive active support in the actions of the Verkhovna Rada and the Government and influence the formation of a favorable regulatory framework for competition.

The competitiveness of agro-industrial production depends on natural and climatic conditions and features of agriculture, directly determined by

Views of economists on the category

Author	Definition of competitiveness
S.I. Ozhogov	Ability to withstand competition, to resist competitors
M.I. Knysh	The degree of attractiveness of this product for the real consumer
Porter Michael	The property of a product, service, subject of market relations to appear on the market along with similar goods, services or competing subjects of market relations. Evaluation of this property allows to distinguish high, medium and low competitiveness
P.V. Zabelin, N.K. Moiseeva	Ability to make a profit in the short term not lower than the specified, or exceeding the average profit
V.P. Groshev	The complex of consumer properties of the goods defining its difference from other similar goods on degree and level of satisfaction of needs of buyers and expenses for its purchase and operation
A.I. Kredisov	Characteristics of the product, reflecting its difference from similar competitive goods both in the degree of compliance with a specific need and the cost of its satisfaction
W. Stevenson	Describes how effectively a company meets the needs of the customer compared to other companies offering a similar product or service
M.O. Ermolov	Relative characteristic that reflects the differences in the development of a particular manufacturer from a competitor's manufacturer both in the degree of satisfaction with their own goods and the efficiency of production activities
A. Pechinkin and V. Fomin	A complex multifaceted concept that defines the ability of a product to take and maintain a position in a competitive market in a given period in competition with other similar products
V.E. Khrutsky, I.V. Korneeva	Stable ability to meet certain customer needs better than competitors, and thus successfully sell products with acceptable financial results for the manufacturer
R.A. Fatkhutdinov	Property of an object characterized by the degree of actual or potential satisfaction of a specific need compared to similar objects presented in a specific market
I.O. Piddubny, A.I. Piddubna	Potential or realized ability of an economic entity to operate in a relevant external environment, which is based on competitive advantages and reflects its position in relation to competitors
B.A. Reisberg	Real and potential opportunity of firms in their existing conditions to design, manufacture and sell goods that are more attractive to consumers in terms of price and non-price characteristics than the goods of their competitors

Source: [26]

the presence of competitive industries and enterprises. The basis of their comprehensive assessment is the competitiveness of products. Product competitiveness is a comparative characteristic that determines the difference between the analyzed products from competitors' counterparts and contains a comprehensive assessment of the totality of its properties in relation to the identified market requirements or qualities of another product.

The competitiveness of the enterprise is a complex comparative characteristic that reflects the degree of superiority of the set of indicators of evaluation of the enterprise, which determine its success in a particular market over a period of time relative to the set of indicators of competing enterprises.

The main groups of competitiveness indicators are shown in Figure 3.

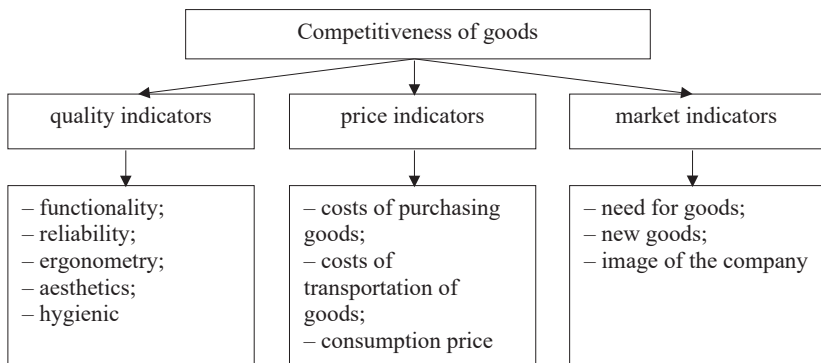

Figure 3. Indicators of product competitiveness

Source: [21]

5. Competitiveness of production in the agro-industrial complex

Competitiveness of production in the agro-industrial complex is characterized by a set of indicators of the functioning of industries and activities of production structures that determine their stable development and success in competition in domestic and foreign markets. It is assessed by the level of competitiveness of its individual enterprises and their products.

Competitiveness of production in the agro-industrial complex largely depends on resource supply. Analyzing this problem in the historical aspect,

it should be noted that initially took into account the dependence on the presence of three main factors of production – natural resources, labor and capital. With the development of production and technical progress, competitiveness began to be determined by higher-level factors, the so-called developed – this is primarily infrastructure, scientific potential, level of education and more.

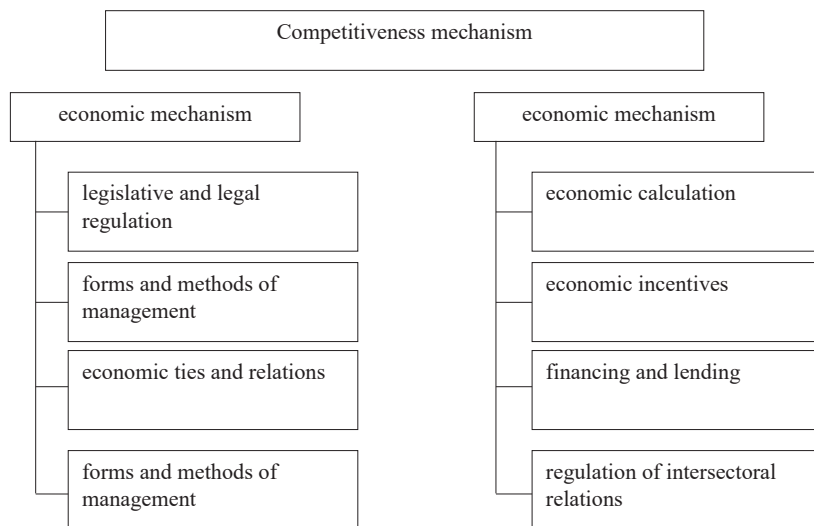

Figure 4. The structure of the mechanism for increasing the competitiveness of agricultural enterprises

Source: [25]

The decisive role in creating competitive advantages of agro-industrial production is played by specialized factors, special infrastructure, special knowledge in the form of scientific and technical databases, the availability of specialists in the relevant field of knowledge and more. Analysis of Ukraine’s main factors of production and efficiency of their use in comparison with economically developed countries shows that our country has a high rating in the provision of agricultural land, labor resources, scientific potential, but the efficiency of these factors Ukraine ranks last [18, p. 41]. However, world experience shows that the presence

of factors of production is an important but insufficient condition for successful competition. This still requires a certain demand for products, in particular, demanding consumers, competitive suppliers and associates, fair competition, the appropriate strategy of enterprises for their development and competitiveness.

The competitiveness of agricultural production largely depends on the external environment, which is based on state policy on agricultural development and related sectors of the agro-industrial complex.

In the development of competitiveness of production in the agro-industrial complex agro-industrial policy should be aimed at solving the following tasks:

- improving the regulatory framework for the development of a competitive environment, preventing monopolies in the domestic market and creating a level playing field for competing entities;

- development of demanding demand for products and services by introducing progressive quality standards, expanding the legal framework of consumer societies, disseminating reliable information about goods and services;

- encouraging enterprises to pursue a global strategy for development prospects, efficiency, competitiveness and export expansion;

- continuous development and improvement of infrastructure

- transport, telecommunications, communications, education, health and science;

- conducting a coordinated international structural policy to develop the competitiveness of producers and ensure a level playing field. Thus, by pursuing an active agro-industrial policy, the instrument of which is fair competition, it is possible to achieve the desired coordination of the interests of the state and business entities.

At the same time, the state only creates appropriate conditions for the emergence and improvement of factors of competitive advantage, and directly create these advantages by producers. Assessing the competitiveness of products, the consumer takes into account their needs and the degree of their satisfaction with this product. The rational consumer, having certain limited opportunities (financial, time, etc.), tries to maximize the usefulness of product consumption.

For the manufacturer, the main criterion for evaluating the product is the amount of profit he will receive from the sale of his (goods) sales.

In assessing the competitiveness of the enterprise, the manufacturer considers it as its competitor, and the most important is the ratio of price and quality of products, compliance with various norms and standards. The industry is assessed by the manufacturer in terms of competitive conditions in the industry and its position in the market. The producer evaluates the country in terms of the availability of the necessary resources, their quality and availability (physical and economic). Increasing the efficiency of agriculture largely determines the solution of the food problem and improving the welfare of the population of Ukraine.

The functioning of production in market conditions requires effective mechanisms of economic regulation. To assess economic efficiency, a system of indicators is used, which is due to its specificity, versatility and depends on a number of factors: natural, industrial, technological and economic.

The criterion for the effectiveness of any component of the agro-industrial complex is the maximum satisfaction of the needs of the population with quality products, and industry – agricultural raw materials to load production capacity based on cost reduction and material and financial resources [6, p. 68]. In the post-reform period, the organizational and economic mechanism and its factors are aimed at obtaining more profit and increase the profitability of advanced capital.

The essence of the criterion of economic efficiency is associated with its content, form, purpose and functions. In the process of production, the needs of people are met, and added value is created, which is used to reproduce and further develop the productive forces. In order to increase the production volumes with the corresponding demand, the mass of profit increases at the same time, as a source of capital accumulation for the development of productive forces [8, p. 81–82].

The introduction of a single efficiency criterion would greatly simplify the assessment of economic performance of production entities, but it is too difficult to develop such a criterion, as it must take into account not only economic but also environmental and social aspects. With the help of the system of indicators it is possible to carry out a comprehensive analysis of the economic activity of the sugar beet subcomplex, to identify unused capacity and to justify ways to increase production efficiency. The system of indicators should characterize: the use of production resources; basic economic processes; final results of activity.

The efficiency of agricultural production affects the level of prices for food and goods made from agricultural raw materials, and is characterized by: the ratio of gross output, net income and profit to the size of land. Improving production efficiency contributes to increasing incomes and increasing the profitability of agricultural enterprises.

Parameters of product competitiveness can be divided into economic, technical and regulatory (Figure 5).

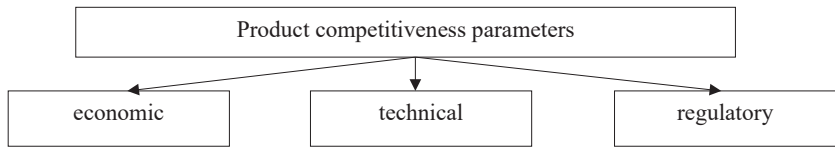

Figure 5. Product competitiveness parameters

Source: [14]

Technical and regulatory parameters together characterize the quality of the product, its environmental friendliness and safety.

Technical parameters determine the technical and physical characteristics of products during consumption or operation. Among the technical parameters are ergonomic, aesthetic and purpose parameters. Ergonomic properties of the product characterize the degree of convenience of its consumption or use by man in various aspects (physical, psychological, anthropometric). Aesthetic parameters characterize the originality of product design (shape, composition, appearance). Destination parameters reflect the direction of use of the product and describe the functions it performs. They reflect the beneficial effect of consumption or operation of products in specific conditions.

Economic parameters take into account the economic costs associated with production, consumption, destruction of products. One-time costs include product prices, transportation costs, setup and trial run. Current costs are the cost of consumption of products, which includes maintenance costs, energy sources, auxiliary materials, repairs, spare parts and more.

Regulatory parameters include parameters of safety, patent purity and environmental friendliness. The parameters of safety and environmental friendliness reflect the requirements for products in accordance with

Chapter «Economic sciences»

current national and international standards, laws and regulations, technical regulations, the results of product certification [1, p. 103].

Competitiveness indicators are a set of criteria for quantifying the level of product competitiveness, based on the parameters of competitiveness [24, p. 101].

Table 2

Characteristics of competitiveness indicators

Indicator Competitiveness	Characteristics
1. Criterion of efficiency of production activity of the enterprise (EV)	
1.1 Cost Level (CO)	Displays cost effectiveness in production
1.2 Return on assets (F)	Characterizes the efficiency of the use of fixed assets
1.3 Profitability of goods (RT)	Characterizes the degree of profitability of goods
1.4 Labor productivity (PP)	Reflects the degree of organization of production and use of labor
2. Criterion of financial condition of the enterprise (FS)	
2.1 Coefficient of autonomy (KA)	Characterizes the independence of the enterprise from external sources of financing
2.2 Coefficient of coverage (CP)	Reflects the company's ability to meet its financial obligations and determines the probability of bankruptcy
2.3 Absolute liquidity ratio (CL)	Shows the qualitative composition of funds that are sources of current liabilities
2.4 Turnover ratio of current assets (CO)	Characterizes the rate of turnover of all current assets and allows you to analyze the possibility of releasing them from economic activity
3. Criteria for the effectiveness of sales organization (EU)	
3.1 Profitability of sales (RP)	Characterizes the degree of profitability of the enterprise in the market, the correctness of pricing
3.2 Finished goods overload ratio (CU)	Displays the degree of finished product overload. An increase in the indicator indicates a drop in demand
3.3 Capacity utilization factor (KV)	Shows the business activity of the enterprise, the efficiency of the sales service
3.4 Advertising efficiency ratio (AD)	Shows the cost-effectiveness of advertising and sales promotion

Source: [9]

These indicators are important in the comprehensive assessment of product characteristics and determining its level of competitiveness. Proper evaluation of the product reduces the risks associated with the company's activities in a new market, but in the meantime, inconsistencies with the actual characteristics of the product may cause a decrease in the efficiency of the company. The indicator of product competitiveness should take into account as many factors as possible and objectively determine their impact on the competitiveness of goods [23, p. 40].

6. The concept of organizational and economic mechanism for managing the competitiveness of enterprises

Competitiveness is a system of indicators that allows you to assess the position of the enterprise, namely: competitiveness of products, technology, equipment potential, staff level, management system, level of innovation, communications, level of marketing policy, export-import opportunities and other parameters [5].

This mechanism is a specific multifunctional system consisting of a set of interconnected elements, among which the categories of level management and competitiveness system are distinguished (Figure 6).

The system of these indicators must be constantly improved in order to adapt the company to various unforeseen situations in the future. Entering the market with a competitive product is only the initial, initial stage in the work of the enterprise to develop in the consumer market, then complex, systematic work on managing the competitiveness of the enterprise. Therefore, special attention should be paid to the development of organizational and economic mechanism, which would not only create favorable conditions for efficient operation, but also provide it with a high level as a competitive enterprise [7].

Assessment of product competitiveness can be carried out by various methods. The choice of a specific method of assessing competitiveness depends on a number of factors (product specificity, urgency of determining the level of competitiveness, the amount of available reliable information, etc.). To date, we can distinguish the following methods:

- 1) depending on the nomenclature of criteria: direct and indirect;
- 2) depending on the purpose and stage of evaluation: methods used at the stage of manufacturing and used at the stage of selling products;

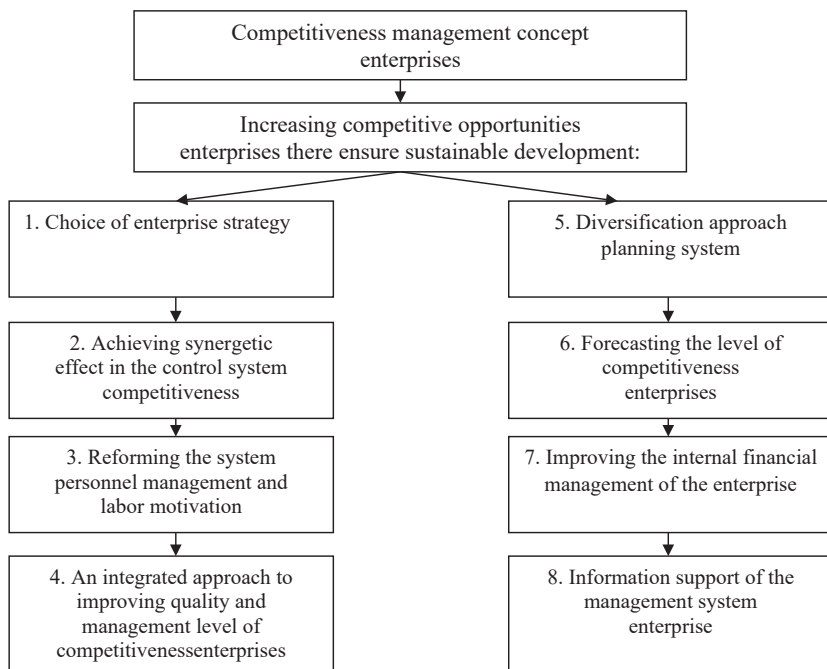

Figure 6. The concept of organizational and economic mechanism for managing the competitiveness of enterprises

Source: improved by the author based on [20]

3) depending on the form of data presentation: calculation, matrix, graphical, combined;

4) depending on the comparison of product properties: qualimetric;

5) depending on the comparison with the sample to determine the relative level of quality: differentiated, complex, mixed.

The competitiveness of products is influenced by price and non-price factors. The first group includes product quality, costs of production, sales and consumption, selling prices, external information. Non-price factors include time and internal information, the costs of which are already included in the costs of the enterprise. The leading role is played by the factors of the economic mechanism, among which are pricing, financing,

lending, stimulating public demand for products, exports and more. One of the main factors for increasing the competitiveness of products are the factors of the state level of government, as they determine the level of consumer welfare and demand, the development strategy of the enterprise, the region and the country as a whole.

Among the listed factors of competitiveness of production the following are of great importance: usefulness for the consumer (conformity to the requirements put forward to the given goods by the buyer); product price; novelty (originality and uniqueness of products); production quality.

The use of the latest technologies, including resource-saving, modern machinery and equipment, materials, high-quality raw materials are among the factors of product competitiveness. An equally important stage in the company's activities is the development of programs to increase competitiveness.

Among the main ways to increase competitiveness are the following: a detailed study of consumer needs and analysis of major competitors; correctly and qualitatively substantiated advertising policy of the company; creation of a novelty product and increase of its qualitative characteristics; search and provision of competitive advantages of goods in comparison with substitute goods; identifying the advantages and disadvantages of similar products, and the use of the results obtained in the company's activities; updating of machines and equipment; constant control over the reduction of the cost of goods; improving the quality of service and maintenance; differentiation of manufactured goods; strengthening the impact on consumers of goods to ensure competitive advantage, etc. [12].

The concept of enterprise competitiveness management [3, p. 41]:

1. Choice of enterprise strategy. This will create competitive advantages (in particular, the advantage in reducing costs, product differentiation, market segmentation, innovation, rapid response to market needs).

2. Achieving a synergistic effect in the competitiveness management system. This concept requires a radical restructuring of the organizational structure of management; creation of productive centers of profit and responsibility for the results of activities; introduction of an integrated approach to the reorganization of the system and structure of the internal environment of the enterprise; improving organizational forms and methods of marketing research.

3. Reforming the personnel management system and work motivation. The concept is based on the development of an effective system of recognition of labor merits, the introduction of methods of incentives and remuneration, improving the mechanism of motivation and responsibility for competitiveness; reorganization of the system of training and retraining taking into account the requirements of strategic management; ensuring employee participation in management decisions.

4. An integrated approach to improving the quality of management of the level of competitiveness of the enterprise involves: the introduction of advanced technological processes; development of an effective strategy of foreign economic activity, technical re-equipment and modernization of production, development and implementation of a comprehensive quality management system; intensification of investment and innovation activities.

5. Diversification approach planning system. The concept provides the use of long-term business planning as a tool for creating long-term competitive advantages; formation of long-term and annual cost budgets; improvement of methods of planning and analysis of production costs; development of organizational and economic measures for the implementation of long-term, current and operational plans.

6. Forecasting the level of competitiveness of the enterprise using modern methods (method of preferences, “profile method”, matrix method and method of integrated evaluation).

7. Improving the internal financial management of the enterprise.

8. Information support of the enterprise management system, ie the creation of a single integrated system of planning, rationing and cost accounting; technical support of the information system of internal management of the enterprise.

Assessment of the competitiveness of goods – a set of operations to choose the criteria of competitiveness, establishing the true values of these indicators for competing products and comparing the values of the analyzed goods with the goods accepted as basic (Figure 7).

1. Methods of assessing the competitiveness of goods through their rating – the implementation of a comprehensive assessment of quality based on technical parameters of products.

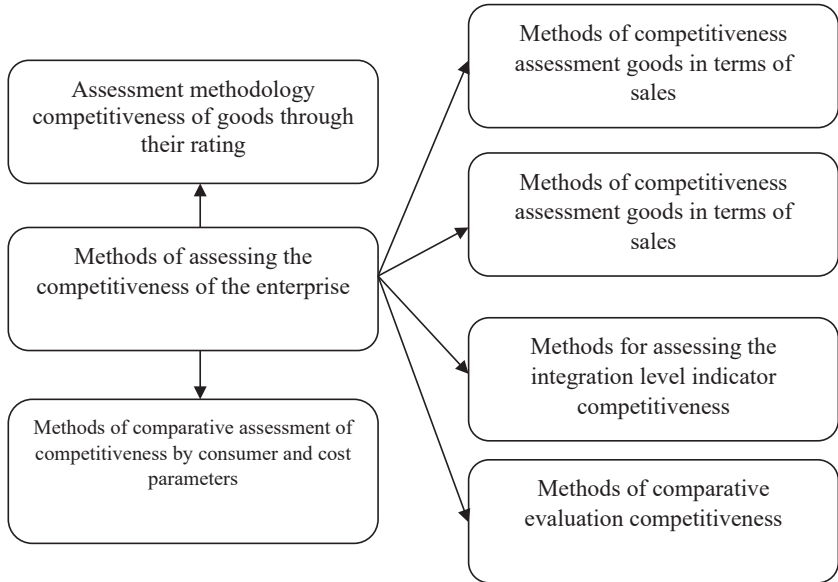

Figure 7. Methods of assessing the competitiveness of the enterprise

Source: [3]

2. Methodology for assessing the competitiveness of goods in terms of sales – the methodology is based on indirect measurement of competitiveness in terms of sales.

3. Methods of determining a comprehensive indicator of competitiveness – product compliance with standards and norms in comparison with the products of competitors.

4. The method of assessing the integration indicator of the level of competitiveness is a relative indicator that reflects the difference between the analyzed products from the competitor’s products in terms of the degree of satisfaction of a specific social need.

5. Methods of comparative assessment of competitiveness – comparison with products by the standard of competitors.

6. The method of comparative assessment of competitiveness in terms of consumer and cost parameters is a comparative characteristic of consumer and quality properties of products [4].

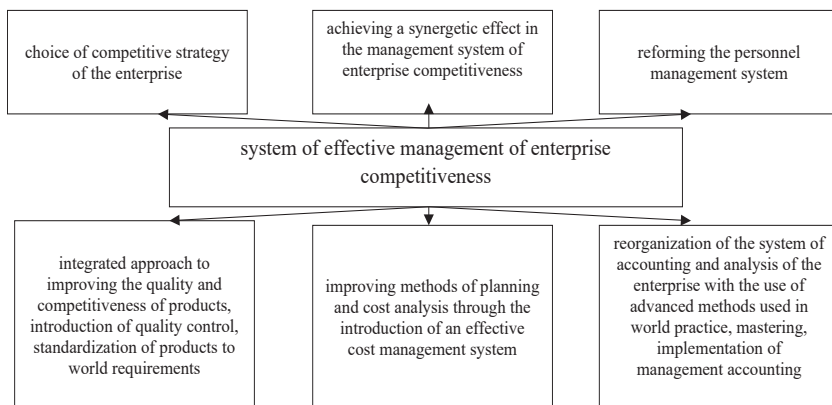

Figure 8. The system of effective management of enterprise competitiveness

Source: [7, p. 36]

The list of indicators, their purpose, positive trends and calculation method are presented in table 2.

Thus, solving complex problems of strengthening the competitiveness of an enterprise operating in a globalized market, offers a complex organizational and economic system of its management. The described system consists of eight interconnected blocks, which include a set of actions and measures to increase the competitiveness of the enterprise in all aspects of its activities. Competitiveness parameters – in the vast majority of quantitative characteristics of the properties of the product, taking into account the industry characteristics of assessing its competitiveness.

Competitiveness indicators are a set of criteria for quantifying the level of product competitiveness based on relevant parameters.

The main ways to increase competitiveness include the following: properly and well-founded marketing policy of the firm; creation of a new product and improving its quality characteristics; search and provision of advantages of goods in comparison with substitute goods; identifying the advantages and disadvantages of similar products, and the use of the results; updating of machines and equipment; constant control over the reduction

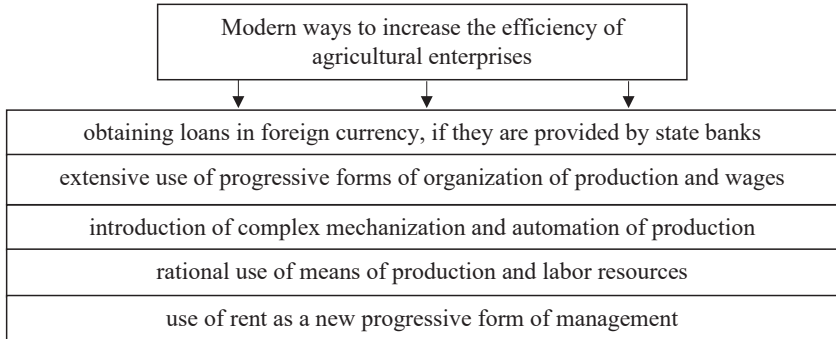

Figure 9. Modern ways to increase the efficiency of agricultural enterprises

Source: created by the author based on [20]

of the cost of goods; improving the quality of service and maintenance; differentiation of goods.

Ways to increase the efficiency of agricultural enterprises. It should be noted that the achievement of a certain level of success of the enterprise is inextricably linked with the acquisition of the enterprise signs of competitiveness.

7. Conclusions

Improving the efficiency of enterprises is to ensure the maximum possible result for each unit of labor, material and financial resources. The main directions are to provide enterprises with the latest technologies, improve management, organization of production and labor, resource efficiency and more. Only the correct use of the system of these factors can ensure a high rate of growth of production efficiency.

Since the effectiveness of any modern organization is determined by the number, form, meaning and content of its elements, the place they occupy in this type of economic systems, as well as existing relationships between them, competitiveness assessment plays an important role in determining the level and prospects. It is necessary to determine the most rational way to build feedback in the organizational and economic mechanism of managing the competitiveness of agro-industrial enterprise for its effective functioning and development.

To form a rational economic environment in agriculture, increase the competitiveness of agricultural formations it is necessary to: improve the pricing system in intersectoral relations between production, procurement and processing of agricultural products through the use of the concept of production price calculated on the basis of profit taking into account the turnover of working capital in order to ensure the reimbursement of regulatory costs, as well as equal income per unit of resources.

In order to increase the competitiveness of production in the agro-industrial complex, it is necessary to introduce a mechanism of state support for agricultural production through the use of preferential taxation and credit, price regulation of parity development, production subsidies, stimulating innovation and more.

References:

1. Bashuk H. O. (2013). Ekonomiko-innovatsiina model konkurentospromozhnosti produktsii v Ukraini [Economic and innovative model of product competitiveness in Ukraine]. *Ekonomika ta derzhava*, vol. 6, pp. 102–106.
2. Bazylevych V. D. (2010). *Ekonomichna teoriya. Politekonomiya. Praktykum: navch. posib.* [Economic theory. Political economy. Workshop: textbook. way]. Kyiv: Znannya. (in Ukrainian)
3. Bieliaiev O. O., Bebelo A.S. (2012). *Politychna ekonomii: navch. posib.* [Political economy. textbook. way]. Kyiv: KNEU. (in Ukrainian)
4. Dovhan L. Ie., Karakai Yu. V., Artemenko L. P. (2011). *Stratehichne upravlinnia navch. posib.* 2-he vyd [Strategic management]. Kyiv: Tsentri uchbovoi literatury, p. 440. (in Ukrainian)
5. Honcharuk I. V. (2020). Enerhetychna nezalezhnist yak suspilno-ekonomichne yavyshe [Energy independence as a socio-economic phenomenon]. *Ekonomika ta derzhava*, vol. 8, pp. 71–77. Available at: <http://www.economy.in.ua/?op=1&z=4722&i=12> (accessed 02 February 2022).
6. Hrytsenko A. P. (2007). Osoblyvosti formuvannia systemy upravlinnia ahropromyslovym vyrobnytstvom v rehioni na innovatsiinii osnovi [Features of the formation of the management system of agro-industrial production in the region on an innovative basis]. *Ekonomika APK*, vol. 9, pp. 3–7.
7. Kaletnik H. M., Kolomiets T. V. (2020). Pidvyshchennia efektyvnosti funkcionuvannia pidpriemstv APK na osnovi formuvannia i vykorystannia intelektualnogo kapitalu [Improving the efficiency of agricultural enterprises on the basis of the formation and use of intellectual capital]. *Ekonomika, finansy, menedzhment: aktualni pytannia nauky i praktyky*, vol. 4(54), pp. 7–19.
8. Khareba V. V. (2012). *Naukovi aspekty vyrobnytstva bioetanolu v Ukraini* [scientific aspects of bioethanol production in Ukraine]. Mizhnarodna naukovo-tekhnichna konferentsiia tsukrovkyv Ukrainy. Available at: <http://www.sugarconf.com> (accessed 02 February 2022).

9. Kucz L. L. (2003). Konkurentna stiikist ta rynek: Otsinka konkurentospromozhnosti yak chynnyk vyznachennia stiikosti pidpriemstva na rynku [Competitive stability and the market: Assessment of competitiveness as a factor in determining the stability of the enterprise in the market]. *Lehka promyslovist*, vol. 3, pp. 37–58.

10. Manuilovych Yu. M. (2013). Doslidzhennia sutnosti ta traktuvannia ponattia konkurentospromozhnosti pidpriemstva [Research of the essence and interpretation of the concept of enterprise competitiveness]. *Marketynh i menedzhment innovatsii*, vol. 4. Available at: http://www.irbis-nbuv.gov.ua/cgi-bin/irbis_nbuv/cgiirbis_64.exe?C21CO (accessed 02 February 2022).

11. Myntsberh H. (2020). *Struktura v kulake: sozdanye efektyvnoi orhanyzatsyy* [Fist structure: creating an effective organization] / Per. s anhl. pod red. Yu. N. Kapturevskoho.

12. Oskolskyi V. (2007). Pro perspektyvy stanovlennia konkurentospromozhnoi rehionalnoi ekonomiky [On the prospects of becoming a competitive regional economy]. *Ekonomika Ukrainy*, vol. 12, p. 11.

13. Ponomarok I. F., Poliakova E. I. (2004). Metodolohichni osnovy i sotsialno-ekonomichni peredumovy udoskonalennia orhanizatsiino-ekonomichnoho mekhanizmu upravlinnia pidpriemstvom [Methodological bases and socio-economic prerequisites for improving the organizational and economic mechanism of enterprise management]. *Naukovi pratsi Donetskoho nats.-tekhn. un-tu*, vol. 69. Donetsk Donetskyi NTU, pp. 53–60.

14. Porter M. E. (2009). *Stratehiia konkurentsii* [Competition strategy] / Per. z anhl. A. Oliinyk, R. Silskyi. Kyiv: Osnovy, p. 390.

15. Pronko L. M., Kolesnyk T. V., Samborska O. Iu. (2020). Vplyv restrukturyzatsii na efektyvnist roboty ahramykh pidpriemstv v umovakh perekhidnoi ekonomiky [The impact of restructuring on the efficiency of agricultural enterprises in transition economies]. *Colloquium-journal. Wydrukowano w Chocimska*, pp. 25–33.

16. Sabluk P. T., Sabluka P. T., Mesel-Veseliaka V. Ya. (2000). *Posibnyk po reformuvanniu silskohospodarskykh ta pererobnykh pidpriemstv*. Vyd. 2-he dopov. [Guide to the reform of agricultural and processing enterprises]. Kyiv: IAEUAAN, p. 660. (in Ukrainian)

17. Shumpeter Y. (1982). *Teoriya ekonomicheskogo razvitiya (Issledovanie predprinimatel'skoj prybyli, kapitala, kredita, procenta i cikla konyunktury)* [The Theory of Economic Development: An Inquiry Into Profits, Capital, Credit, Interest, and the Business Cycle, Progress] / per. s anhl. Moscow: Prohress, pp. 41–170. (in Russian)

18. Stepankova A. A. (2012). Metody otsinky konkurentospromozhnosti produktsii. *Efektyvna ekonomika*, vol. 2. Available at: <http://www.economy.nayka.com.ua/?op=1&z=954> (accessed 02 February 2022).

19. Struktura hospodarskoho mekhanizmu Vnutrishnii ekonomichnyi mekhanizm pidpriemstva [The structure of the economic mechanism Internal economic mechanism of the enterprise]. Available at: http://bookwu.net/book_vnutrishnij-ekonomichnij-mekhanizm-pidpriemstva_1077/12_struktura-gospodarskogo-mekhanizmu

20. Tarasiuk H. M., Shvab L. I. (2020). *Planuvannia diialnosti pidpriemstv. Navchalnyi posibnyk* [Business activity planning]. Kyiv: Karavela, p. 432. (in Ukrainian).

21. Treshchov M. M. (2009). Metody otsiniuvannia konkurentospromozhnosti produktiv [Methods of assessing the competitiveness of products]. *Ekonomichnyi prostir*, vol. 23/1, pp. 118–126. Available at: http://www.nbuv.gov.ua/portal/Soc_Gum/Ekpr/2009_23/1/treshov.pdf

22. Valinkevych N. V., Solotvinskyi O. A. (2014). Teoretychnyi pidkhid do upravlinnia konkurentospromozhnistiu pidpriemstva [Theoretical approach to enterprise competitiveness management]. *Molodyi vchenyi*, vol. 12(1), pp. 84–89.

23. Yudin M. (2010). Porivnialna kharakterystyka metodiv otsinky konkurentospromozhnosti produktiv [Comparative characteristics of methods for assessing the competitiveness of products]. *Ekonomist*, vol. 6, pp. 40–42. Available at: http://www.nbuv.gov.ua/portal/Soc_Gum/Ekonomist/2010_6/4042.pdf

24. Zahorodnii A. H., Chubai V. M. (2007). Otsiniuvannia konkurentospromozhnosti innovatsiinoi produktiv v protsesi vyboru innovatsiinoi stratehii pidpriemstva [Assessing the competitiveness of innovative products in the process of choosing the innovation strategy of the enterprise]. *Finansy Ukrainy*, vol. 1, pp. 99–110.

25. Zheluzhenko K. V. (2017). Sutnist ta faktory konkurentospromozhnosti produktiv pidpriemstv Ukrainy [The essence and factors of competitiveness of products of Ukrainian enterprises]. *Intelekt XXI*, vol. 1. Available at: http://www.intePect21.pyi.org.Ua/j_oyhpaI/2018/2018 (accessed 02 February 2022).

26. Zhurba I. O., Koliadenko Yu. M. (2012). Sutnist i znachennia konkurentospromozhnosti pidpriemstva [The essence and importance of enterprise competitiveness]. *Zbirnyk naukovykh prats*. Available at: http://r250Sudueduaa/bitstream/123456789/52304/7/ZhurbaSutnistznachennia_konkurentospromozhnosti%20pdf

FINANCIAL SUSTAINABILITY OF AGRICULTURAL ENTERPRISES: DEVELOPMENT AND APPROVAL OF THE INTEGRATED EVALUATION MODEL

Oleksandr Shevchuk¹
Svitlana Kiporenko²

DOI: <https://doi.org/10.30525/978-9934-26-193-0-14>

Abstract. The methodological and practical bases of integrated assessment of the financial condition of an agricultural enterprise are considered in the work. It is emphasized that the integrated method of assessment is the most objective for such an analysis, as it allows you to quantify and evaluate the relationship between the main factors and predict their level in the future. An expert method was used to determine the system of basic relative indicators for assessing the level of financial stability of the enterprise and their ratios. Verification of co-ordination of opinions of experts was conducted by the method of grade correlation with a calculation to the Kendall's coefficient of concordance and determination of statistical importance of opinions of experts on the Pearson criterion χ^2 . The normative values of indicators were also adapted in accordance with the specifics of the industry and modern operating conditions. The values of the standards were determined on the basis of the results of financial and economic activities of the most efficient enterprises in the region, selected by the method of rating and scoring. Approbation of the developed model of financial condition assessment was carried out on the basis of financial reporting data of agricultural enterprises of Vinnytsia district for five years. The obtained results of calculations were used to check the presence of multicollinearity of factor features, which allowed to establish linearly dependent groups of relative indicators and to optimize the proposed model accordingly. A detailed econometric analysis of a number of dynamics of the integrated indicator of financial stability over ten years was conducted

¹ Candidate of Physical and Mathematical Sciences, Associate Professor of the Department of Mathematics, Physics and Computer Technologies, Vinnytsia National Agrarian University, Ukraine

² Assistant of the Department of Computer Science and Economic Cybernetics, Vinnytsia National Agrarian University, Ukraine

on the example of the most successful agricultural enterprise of Vinnytsia district. Theoretically and practically checked the presence of anomalous levels; the presence of a trend is determined; smoothing and alignment of a number of dynamics is carried out; the trend model is selected and its parameters are calculated; the trend model for adequacy, accuracy and presence of autocorrelation of residues is investigated; point and interval forecasting was carried out.

1. Introduction

System crisis phenomena in an economy of agrarian sector of Ukraine led to deterioration of its socio-economic development, slowing down the production of goods in agricultural enterprises and, as a result, worsening of their financial state. This situation does not contribute to an effective innovation policy, reduces the competitiveness of agricultural products, slows down Ukraine's integration processes into the European and world community. The urgency of improving the financial security of agricultural enterprises in such conditions becomes the most important task of both the state and the business. The search for opportunities to strengthen the financial situation should contribute to a systematic and objective analysis of agricultural enterprises, the results of which allow operatively to react on the change of external and internal environment of business, accept reasonable administrative decisions from the financial adjusting must assist. The criterion for the effectiveness of such decisions is the level of financial stability of economic entities, which assesses the adequacy of financial resources for balanced sustainable development of agricultural enterprises.

Assessment of the financial stability of an agricultural enterprise should be generalized, integrated, and give an unambiguous answer about the level of financial stability of the enterprise. It must accumulate all the main aspects of the operation of the enterprise, that is mean to take into account the importance of the most important indicators of financial and economic activities of economic entities.

In agriculture, unlike other industries, there is a complex system of relationships and dependencies, intertwining of various factors, including natural, related to the biological properties of objects and working conditions. To take into account all these parameters in a mathematical model – it is practically impossible. Therefore, it follows to take into account

at development and use of such model, that not all phenomena and factors can be in number expressed, that complicates their plugging in a model.

Than deeper and more detailed analysis is conducted, than more difficult (branched) is the mathematical model, the more chances we have to get around the real reflection of reality of the investigated phenomena, and the higher the practical value of the model of analysis, and in our case – assessment and management of financial stability of agricultural enterprises.

Economic and mathematical modeling of the assessment of financial stability of the enterprise will quantify the relationship between the main factors that determine it and the magnitude of their impact.

The integrated method is objective because it includes any assumptions about the role of factors in the analysis. Unlike other methods of factor analysis, the integral method fulfills the condition of factor independence. Another important feature is that this method gives a general approach to solving problems of various kinds, regardless of the number of elements included in the model of the factor system, and the form of relationships between them.

Due to the numerous shortcomings of the existing methods of determining the level of financial stability of enterprises, the lack of real modern standards, adjusted to the characteristics of agricultural enterprises, the development of such methods is currently quite relevant.

The basis for an integrated assessment of financial stability is a group (or system of groups) of relative indicators that characterize the financial and economic activities of the enterprise. In the scientific literature, foreign and Ukrainian authors offer a significant number of such indicators and methods of their calculation. Therefore, the primary and most important stage of model development is the construction of such a base of indicators, in which the analysis will be reliable and multifaceted, and the number of selected factor characteristics will be optimal and linearly independent. Expert assessment method was used to select a system of basic indicators that meet the above requirements.

2. Expert assessment method

In cases when for some reasons it is impossible to obtain the necessary economic information (information array is limited or absent), it is appropriate to use the methods of expert assessments. They are used in

the absence of sufficient and reliable information about the predicted phenomena (processes), as well as in conditions of significant uncertainty of the environment in which the object operates.

The use of expert methods is based on deep knowledge of specialists and the ability to summarize their own and world experience of research and development on a particular problem, the hypothesis of the expert's so-called "practical wisdom", foresight in a particular field of knowledge and practice, the ability to come in the process of certain activities, to assess fairly reliably the importance and significance of research areas, the timing of a particular event, the importance of a parameter, process (phenomenon), etc. [1].

All expert surveys, regardless of the chosen methods of conducting them, are based on the scoring of the objects of research on a given issue and determining their importance. Their main feature is the lack of mathematical confirmation of the optimal conclusions.

Methods based on the use of expert assessments are divided into two groups: individual and collective [1; 2].

Among the known methods of individual expert assessments should be noted the following: control issues; individual brainstorming; interview; script; Delphi method; questionnaire; paired comparisons.

Methods of collective expert evaluation: conference of ideas; brainstorming; "morphological box"; sevenfold search; associations and analogies; Delphi method; collective notebook; control questions; inversions; Pattern.

The division into methods of individual and collective expert assessments is made depending on whether the forecast is developed based on the conclusions of one expert or group of experts.

The main advantages of individual methods of expert assessment are the ability to use the abilities and knowledge of an individual expert, as well as the relative ease of conducting targeted analysis. Their main defect is limit nature of knowledge each of polled about the state and development of contiguous spheres of activity. The advantages of collective methods of expert questioning are: first, that experts agree on an open discussion that allows them to influence each other in such a way as to compensate for each other's mistakes; second, a group of specialists produces more "mental" energy than one specialist; and third, the group of experts is generally more willing to take responsibility for making important, risky decisions. However, these methods have a number of disadvantages:

– the part of the group may have some influence on other members of the group;

– there may be cases when the group thinks that a specialist, such as a great scientist, has a serious influence, and if he has a talent for persuasion, he will be able to decisively implement his ideas through persistent and constant argumentation;

– a thinking sluggishness, “honor of uniform”, convinces certain part of group to incline other members to the acceptance of certain decisions, especially if they were oriented to these decisions from the beginning;

– in groups, as a rule, there is an opinion that reaching an agreement is more important than developing the most reasonable and practically useful forecast [1].

All considered circumstances which are marked higher, as well as the sharp contrast of existing interpretations of the definition and components of financial stability, the only really possible method for research on this topic is the use of individual surveys. Significant shortcomings of collective expert research, as well as doubts about the ability to organize a quality group discussion of real experts in the field make these methods unsuitable for us.

At application of individual methods, from every expert get independent estimations for further them mathematical treatment and acceptance of corresponding decisions. Widespread among them are two methods: interviews and questionnaires. The disadvantage of the interview is that the expert does not have enough time to think about the answers. Therefore, a questionnaire of experts and the use of control questions were used to clarify some important points in the course of this study.

The experts were offered a questionnaire, which included 50 indicators that form the financial stability of the enterprise. The task of the experts was to assess the list of relative indicators proposed in the questionnaire, which characterize the financial stability of agricultural enterprises. The questionnaire provided that experts with a high level of professional knowledge were able to assess the impact of each indicator (factor) on the level of financial stability of economic entities on a ten-point scale.

45 people were involved as experts, including economists of Vinnytsia universities, managers, accountants, employees of analytical and financial departments of a number of agricultural enterprises in Vinnytsia district

and employees of the Main Department of Statistics and the Department of Agriculture in Vinnytsia region.

In the process of practical application of the method, independent estimates were obtained from each expert, which were processed using a mathematical apparatus.

In particular, the method of rank correlation was used to determine the consistency of experts' opinions and the Kendall concordance coefficient was determined [3], which in the absence of related ranks is calculated by the formula:

$$W = \frac{12 \cdot \sum d_i^2}{m^2 (n^3 - n)}, \quad (2.1)$$

Kendall concordance coefficient with associated ranks:

$$W = \frac{12 \cdot \sum d_i^2}{m^2 (n^3 - n) - m \cdot B}, \quad (2.2)$$

where, $d_i = \sum R_{ij} - \frac{\sum_j \sum_i R_{ij}}{n}$ ($i = 1, 2, \dots, m$) – the sum of ranks R_{ij} , provided by all experts i – element of the sample, minus the average value of these sums of ranks; m – the number of experts; n – the sample size (the number of factors or indicators), $B = \sum_k (B_k^3 - B_k)$, where B_k – the number of related (identical) ranks, r – the number of groups of related ranks.

The concordance coefficient can range from 0 to 1 and is an indicator of the tightness of the relationship in the case of multiple regression. The greater the value of the concordance coefficient, the higher the degree of agreement of experts. If, $W = 1$ that is, full agreement of experts' opinions, but when $W = 0$ – there is almost no agreement.

In our analyzed set of factors (indicators) that affect the financial stability of the enterprise concordance coefficient is $W = 0,72$ at a significance level of 0.05 (95%). This means that in the results of the expert assessment there is a non-random agreement of experts what gives us the opportunity among the many factors that may to some extent affect the formation of financial stability of agricultural enterprises to identify those that are most important.

The statistical significance of experts' opinions was tested by Pearson's criterion χ^2 [3]. The estimated value of this criterion is obtained by the formula:

$$\chi_r^2 = \frac{12 \cdot \sum d_i^2}{m \cdot n \cdot (n+1) - \frac{1}{n-1} \cdot B}. \quad (2.3)$$

The resulting value is compared with the tabular value χ_i^2 at $(n - 1)$ degrees of freedom and confidence interval 0.95. Under condition $\chi_r^2 < \chi_i^2$ it is assumed that the concordance coefficient is significant, if $\chi_r^2 > \chi_i^2$ then there is a need to increase the number of experts.

In our case, the following values are obtained: $\chi_r^2 = 23,14 < \chi_i^2 = 28,87$.

This indicates that the concordance coefficient confirms a statistically significant assessment of expert opinions.

Thus, based on the above theoretical analysis of the experiment (questionnaire), taking into account the expert assessments of practitioners in the field of financial stability research, the main factors were identified, without which the assessment of financial stability of agricultural enterprises cannot be considered.

In particular, taking into account the opinions of experts, 19 indicators were selected, which best characterize the financial stability of enterprises in four different areas. That is, based on the results of the expert survey, four subsystems of relative indicators of financial stability were formed (Table 2.1). The table also shows the generally accepted normative values of indicators or the vector of their positive change.

Note that the introduction of methods of integrated assessment of the enterprise is considered in many works of Ukrainian authors [4–20]. At the same time, scientists introduce such concepts as “integrated indicator of the financial condition of the enterprise”, “integrated indicator of the financial potential of the enterprise”, “integrated indicator of anti-crisis potential of the enterprise”, “integrated indicator of enterprise efficiency” and others. A rather diverse set of basic indicators is proposed for their calculation, but arguments for their selection are usually not provided. In particular, evaluating the activity of the machine-building enterprise MOTOR SICH Joint Stock Company (Zaporizhzhia) [4], the author uses 22 financial relative indicators, which are classified into five different groups. However, the article does not provide arguments for the choice of these indicators to calculate the integrated indicator of financial and economic condition of the enterprise.

Table 2.1

Indicators of financial stability of the enterprise

Indicators	Generally accepted standards
I. Degree of financial independence	
1.1 Coefficient of autonomy	> 0,5
1.2 Ratio of own and borrowed funds	> 1
1.3 Rated capital structure ratio	Increasing
1.4 Equity maneuverability ratio	0,4–0,6
1.5 Coefficient of financial stability	> 0,6
II. Liquidity and solvency	
2.1 Coefficient of coverage	> 1
2.2 Current liquidity ratio	> 0,8
2.3 Absolute liquidity ratio (solvency)	0,2–0,35
2.4 The ratio of receivables and payables	> 2
III. Business activity	
3.1 Asset turnover ratio	Increasing
3.2 Mobile funds turnover ratio	Increasing
3.3 Coefficient of circulating of property asset	Increasing
3.4 Coefficient of capital investment	Increasing
3.5 Investment coefficient	0,5–0,7
3.6 Mobility coefficient	Increasing
IV. Profitability	
4.1. Return on assets ratio	Increasing
4.2. Coefficient of profitability of sales	Increasing
4.3. Coefficient of profitability of property asset	Increasing
4.4. Coefficient of profitability of productive capital	Increasing

Quite a thorough analysis of the activities of the industrial enterprise of the State Scientific Production Enterprise «Kommunar Corporation», which specializes in the production of control systems for media and space objects, was conducted in [5]. The overall integrated indicator of the operation of the enterprise was calculated on the basis of partial integrated indicators of the five groups, which included 34 relative indicators. At the same time, such a significant number of model parameters on the one hand significantly deepened the analysis, but on the other hand significantly complicated it. And the share of indicators used was interrelated and showed

a sign of multicollinearity. The authors also did not substantiate the system of selected indicators.

In particular, an integrated assessment of the financial and economic condition of agricultural enterprises in the Kherson region for 2014–2018 was conducted in [6]. The authors assessed the performance of these enterprises on the general integrated indicator, based on the analysis of criteria: financial stability, business activity, profitability, liquidity and solvency, bankruptcy and business development. Unfortunately, the paper provides only a thorough analysis of the results of calculations of these indicators and does not provide the method used to calculate them. Such an integrated assessment of the economic security of machine-building enterprises is carried out in [7; 8].

Thus, the introduction of methods of integrated assessment of the enterprise is a very relevant scientific field, which includes a wide variety of approaches, is widely discussed in the modern scientific literature and has the potential for further research.

Note also that the method of calculating integrated indicators involves the use of a matrix of normative values of the system of selected components. Comparison of the actual values of relative indicators with their standards gives a general idea of the financial and economic condition of the enterprise and determines its level in comparison with the standard. The generally accepted values of standards, as a rule, may not always be sufficiently clear to the specifics of the industry, be only partially relevant to today's conditions, or even have no normative value, and determine only the direction (vector) of positive change. Therefore, the next section will focus on the development of an adapted system of normative values of financial stability indicators.

3. Justification of normative values indicators of financial stability

At the present stage of development of Ukraine's economy, in the agro-industrial sector in particular, there is a certain separation of theory from practice, so a very important and necessary step in creating a model of financial stability of the enterprise is a reasonable definition of normative (optimal) values of economic indicators. Such adaptation of standards, in accordance with current conditions, can be carried out on the basis of economic indicators of one or more of the most successful agricultural

enterprises in the region. In this case, a necessary condition is to take into account the well-known standards that have long been formed and are in force today.

Agriculture, like no other industry, differs significantly in its specifics, and therefore needs exactly “their” standards. The normative limits of the indicators determined will be real and relevant, as they will be developed on the basis of the actual activity of agricultural enterprises in recent years. There is no doubt that the critical (optimal) limits of the main economic indicators must be constantly updated and adapted to the current dynamic environment.

A fairly simple and common method of ranking companies by level of financial stability is to determine their score rating “by the sum of places” [14]. Having the actual values of relative indicators and their standards (or the direction of optimization) (Table 2.1) it is necessary to determine the place of each enterprise on the relevant indicators (in points), and the maximum score is equal to the total number of analyzed enterprises. Summarizing the places obtained by each enterprise for the last four years, the general ranked rating of the level of financial stability of the researched enterprises of Vinnytsia district was determined.

The advantage of this technique is its ease of use, and the disadvantage is the inaccuracy of the results. However, the definition of such a rating is a necessary prerequisite for the development of relevant regulatory values of financial stability of the enterprise.

Thanks to this approach, the best companies and “outsiders” clearly stood out. A rather large gap in the score of the best and worst company confirmed the adequacy of the analysis.

Evaluating the results of the method of calculating the relative indicators of financial stability with the rating of enterprises, it should be noted that the score does not indicate the level of financial stability of the enterprise, but only allows to formally compare the results of economic entities. Also, this method does not take into account the level of importance of the components of financial stability.

Thus, to determine the standards, we chose the most successful profitable agricultural enterprise, which has long been operating in the agricultural market of Vinnytsia. The actual data of indicators of financial stability of this enterprise for the last five years were taken as a basis and

Table 3.1

Normative values of the system of indicators of financial stability, developed on the basis of test farms

Indicators	Generally accepted standards	Proposed standards
I. Degree of financial independence		
1.1 Coefficient of autonomy $K_1^{(I)}$	> 0,5	0,5–0,8
1.2 Ratio of own and borrowed funds $K_2^{(I)}$	> 1	0,1–0,5
1.3 Rated capital structure ratio $K_3^{(I)}$	Increasing	> 1
1.4 Equity maneuverability ratio $K_4^{(I)}$	0,4–0,6	0,1–0,6
1.5 Coefficient of financial stability $K_5^{(I)}$	> 0,6	> 0,6
II. Liquidity and solvency		
2.1 Coefficient of coverage $K_1^{(II)}$	> 1	> 1
2.2 Current liquidity ratio $K_2^{(II)}$	> 0,8	> 0,7
2.3 Absolute liquidity ratio (solvency) $K_3^{(II)}$	0,2–0,35	0,1–0,35
2.4 The ratio of receivables and payables $K_4^{(II)}$	> 2	1
III. Business activity		
3.1 Asset turnover ratio $K_1^{(III)}$	Increasing	> 0,8
3.2 Mobile funds turnover ratio $K_2^{(III)}$	Increasing	> 1,6
3.3 Coefficient of circulating of property asset $K_3^{(III)}$	Increasing	> 3
3.4 Coefficient of capital investment $K_4^{(III)}$	Increasing	> 3,6
3.5 Investment coefficient $K_5^{(III)}$	0,5–0,7	0,5–0,7
3.6 Mobility coefficient $K_6^{(III)}$	Increasing	> 1,7
IV. Profitability		
4.1. Return on assets ratio $K_1^{(IV)}$	Increasing	> 0,2
4.2. Coefficient of profitability of sales $K_2^{(IV)}$	Increasing	> 0,1
4.3. Coefficient of profitability of property asset $K_3^{(IV)}$	Increasing	> 0,1
4.4. Coefficient of profitability of productive capital $K_4^{(IV)}$	Increasing	> 0,15

their adjustment was carried out during the corresponding comparison with achievements of other enterprises of the district. Thus, the optimal (regulatory) limits of indicators were determined and based on the results of not only one enterprise but a group of the most successful agricultural enterprises in the region. This is the main value of the proposed method of setting standards. The results of the research are given in table 3.1.

4. Integrated indicator of financial stability

Also a necessary step in developing a mathematical model is to determine the level of importance of each group of indicators of financial stability in the formation of the overall result. The weights of each group, which differently characterize the level of financial stability of the enterprise, can also be determined only by expert assessments (due to the instability of economic processes in general and the environment in which enterprises operate, in particular). As a result of expert assessment with the help of questionnaires the following weights of individual groups were obtained: Group I (coefficients of financial independence) – 0.30; Group II (liquidity and solvency ratios) – 0.25; Group III (coefficients of business activity) – 0.24; Group IV (profitability ratios) – 0.21.

Thus, the model for calculating the integrated indicator involves taking into account the weights of the components of financial stability and adjusted critical (regulatory) values of each coefficient of the model. To determine the partial integrated indicators of individual subsystems of financial stability, each coefficient sets the degree of achievement of the regulatory level. To do this, calculate the ratio of the actual value to the normative (Table 3.1). Note also that the ratio of actual and normative values of the coefficients should not exceed one. In the case when such an excess is within the optimal limits (Table 3.1), the coefficient is taken equal to one.

That is:

$$K = \begin{cases} \frac{K_f}{K_n}, & \text{if } K_f < K_n ; \\ 1, & \text{if } K_f = K_n ; \\ \frac{K_n}{K_f}, & \text{if } K_f > K_n . \end{cases} \quad (4.1)$$

where K – relative indicator; K_f – the actual value of the relevant indicator; K_n – normative value of the relevant indicator.

The total integrated indicator \mathfrak{I} is calculated by the formula:

$$\mathfrak{I} = \alpha_1 \sum K_i^{(I)} + \alpha_2 \sum K_i^{(II)} + \alpha_3 \sum K_i^{(III)} + \alpha_4 \sum K_i^{(IV)}, \quad (4.2)$$

where $\alpha_1, \alpha_2, \alpha_3, \alpha_4$ – weights of the first, second, third and fourth groups, respectively; $K_i^{(I)}, K_i^{(II)}, K_i^{(III)}, K_i^{(IV)}$ – relative indicators of the first, second, third and fourth groups, respectively.

It should also be noted that the relative indicators of groups I, III and IV may be negative. This will indicate certain crises in the company, the presence of large losses, a small share of equity, a large share of short-term liabilities, and so on.

The above method of calculating the integrated indicator of financial stability was tested on the basis of financial statements of agricultural enterprises of Vinnytsia region for five years.

Calculations have shown that most of the analyzed enterprises are in critical condition ($\mathfrak{I} < 0.5$), and almost half of them have a negative tendency to reduce the level of financial stability, and in some cases the decline is quite sharp. The main reasons for this negative trend in recent years are the loss of agricultural production (namely – livestock), lack of targeted funding, which leads to a decrease in equity and credit problems.

It should also be noted that only three enterprises in the study sample have a high level of financial stability and in recent years there have been no sharp fluctuations in the integrated indicator and positive dynamics.

The introduction of an integrated indicator according to formula (4.2) makes it possible to conduct a more in-depth economic and statistical analysis in two areas:

1) research on the presence of multicollinearity of relative indicators of the model. The audit is conducted in order to simplify the formula for calculating the integrated indicator of financial stability, due to the elimination of linear components. This analysis involves a significant amount of statistics and will therefore be based on the results of the calculation of relative indicators of financial stability of all surveyed enterprises, including taking into account the dynamics of their change over the past five years;

2) economic and statistical analysis of the time series of the integrated indicator of financial stability. This analysis is based on the actual results of one (test) company for the last 10-15 years and will include the following

stages: study of the presence of abnormal levels and the presence of a trend; leveling and smoothing of a number of dynamics; determination of the corresponding growth curve.

5. Study of the presence of multicollinearity indicators of financial stability

In many applied economic problems it is necessary to establish and evaluate the dependence of one random variable Y on another random variable X or several other random variables X_1, X_2, \dots, X_n .

Two random variables Y and X can be related by functional dependence (when each value x of a random variable X corresponds to one and only one value of a random variable Y), statistical dependence (when each value x of a random variable X can correspond to several values y_1, y_2, \dots, y_k of a random variable Y) or be completely independent [21].

The functional relationship between economic indicators can be linear (straightforward) or close to linear, and curvilinear or close to a certain curvilinear relationship.

The most common among economic and mathematical models that express the relationship between economic indicators are linear functions, because even nonlinear relationships can be reduced to linear methods of introducing new variables. But a clear functional dependence (linear or curvilinear) is rarely realized, because both are variables X and Y can be influenced by different factors, and some of them can affect both X and Y at the same time. In this case, there is a statistical dependence.

Statistical is the dependence in which a change in one of the quantities causes a change in the distribution of the other. Set the statistical dependence using a correlation table or correlation field [21].

The statistical dependence is manifested in the fact that each value x_i of a random variable X can correspond to several (rather than one) values $y_{i1}, y_{i2}, \dots, y_{in}$ of a random variable Y . Then we can talk about the dependence of the average value

$$\bar{y}_{x_i} = \frac{y_{i1} + y_{i2} + \dots + y_{in}}{n} \quad (5.1)$$

from x_i , which is functional, given in a tabular way. Thus, $\bar{y}_x = f(x)$ a function that, again, can be linear or close to it or a certain curvilinear or close to it.

The dependence Y on X , the given equation, $\bar{y}_x = f(x)$ is called the correlation dependence, and the equation is called the regression Y on X . The line described by this equation is called the regression line Y on X .

It is known that the degree of correlation depending on two random variables Y and X is the correlation coefficient

$$\rho(X, Y) = \frac{M(XY) - M(X) \cdot M(Y)}{\sqrt{D(X) \cdot D(Y)}}, \quad (5.2)$$

where $M(X)$ – mathematical expectation, $D(X)$ – dispersion.

For arbitrary random variables X, Y :

$$-1 \leq \rho(X, Y) \leq 1. \quad (5.3)$$

If $\rho(X, Y) = \pm 1$, then the values X, Y – are linearly dependent, if $\rho(X, Y) = 0$, then the values X, Y – uncorrelated to which belong and independent. If the number $|\rho(X, Y)|$ close to one, then points $(x_1; y_1), (x_2; y_2), \dots, (x_k; y_k)$ lie almost on a straight line [21].

In the case of studying the dependence of several random variables (compilation of multifactor mathematical models, which corresponds to our case), a matrix of paired correlation coefficients (correlation coefficients of pairs $X_i X_j$) is considered. It is called the correlation matrix. With the help of this matrix it is possible to estimate the presence of a linear relationship between individual random variables of the studied population. In this case, if the random variables X_1, X_2, \dots, X_n are explanatory (factor) variables of a certain resultant feature Y , and between some of them there is a linear relationship, it is said that in a multifactor model there is multicollinearity. Thus, multicollinearity is the existence of a close linear relationship, or strong correlation, between two or more explanatory variables [3].

The presence of multicollinearity in the evaluation of model parameters can lead to negative consequences that can significantly reduce the practical value of the obtained quantitative characteristics of the relationship or make them inconsistent with the main properties of these estimates and therefore cannot be used in practice. Therefore, the analysis to identify and eliminate multicollinearity is a mandatory step in the development and testing of any multifactor model.

In our case, the proposed integrated indicator of financial stability is a generalization of a set of relative indicators that are to some extent

interrelated, and some of them, given the method of their calculation, may have a fairly close linear relationship. Therefore, the practical use of the proposed model involves checking the presence of multicollinearity among the indicators of the model and measures to eliminate it in case of detection. It should also be noted that in order to obtain reliable results, statistical analysis was conducted using financial statements for five years of all agricultural enterprises in Vinnytsia region. This allowed to significantly increase the size of the studied sample.

The study of multicollinearity was performed using a Microsoft Office Excel spreadsheet using the Farrar-Glauber algorithm [3]. To do this, in the first stage, all 19 indicators of the model were standardized according to the formula

$$x_{ik}^* = \frac{x_{ik} - \bar{x}_k}{\sigma_{x_k}}, \quad (5.4)$$

where $m = 19$ – number of explanatory variables, the indicators of the model ($k = \overline{1, m}$); n – number of surveyed enterprises ($i = \overline{1, n}$); \bar{x}_k – arithmetic mean k - th indicator; $\sigma_{x_k}^2$ – dispersion k -th indicator.

To find the correlation matrix used the formula:

$$r_{xx} = \frac{1}{n} (X^*)^T \cdot X^*, \quad (5.5)$$

where X^* – matrix of normalized indicators; $(X^*)^T$ – matrix transposed to the matrix X^* . Calculations have shown that there is a fairly close linear relationship between certain indicators (the closer the value of the partial correlation coefficients to ± 1 , the closer the linear relationship, and vice versa).

But a more general test involves finding the value of the criterion χ^2 :

$$\chi^2 = - \left[h - 1 - \frac{1}{6}(2m + 5) \right] \cdot \ln |r_{xx}|, \quad (5.6)$$

where $|r_{xx}|$ – determinant of the correlation matrix r_{xx} .

As calculations have shown the value of the determinant of the correlation matrix of the studied population $r_{xx} = -1.23 \cdot 10^{-17}$ and magnitude $\chi_{fact}^2 = 304,95$. The value of this criterion is compared with the table when $\frac{1}{2}m(m-1)$ degrees of freedom and levels of significance α . If, $\chi_{fact}^2 > \chi_{tabl}^2$ then there is multicollinearity in the array of explanatory variables. In our

case, the tabular value for the number of degrees of freedom $l = 171$ and level of significance $\alpha = 0,05, \chi_{tabl}^2 = 120$. Therefore, it was concluded that there is multicollinearity in the proposed model.

After examining the closeness of the relationships between indicators, groups of indicators were identified, between which there is a significant linear relationship:

- 1 group of linear communication: the coefficient of autonomy, the ratio of borrowed and own funds, the coefficient of maneuverability of equity, the coefficient of financial stability;

- 2 group linear relationship: the ratio of receivables and payables and the ratio of investment;

- 3 group linear relationship: asset turnover ratio, equity turnover ratio, mobile assets turnover ratio, return on capital ratio and mobility ratio;

- 4 group linear relationship: return on assets, rate of return on equity, rate of return on production capital.

In order to eliminate multicollinearity, 10 indicators were removed from the proposed model for assessing the level of financial stability, which in turn greatly simplified its appearance and use. The selection of indicators that remained in the model was carried out on the principles of greater general economic significance (content) of coefficients and the maximum exemption from duplication of economic indicators of each other. As a result of selection 9 indicators of model are received (tab. 5.1).

When re-checking for multicollinearity, the calculated value $\chi_{fact}^2 = 33,2$ turned out to be an order of magnitude less than the previously broken value. Comparing it with the tabular value of the distribution χ^2 ($\chi_{tabl}^2 = 49,8$) at the level of significance $\alpha = 0,05$ and the number of degrees of freedom $\frac{1}{2}m(m-1) = 36$, it was concluded that multicollinearity is not observed in the simplified model of integrated assessment of the level of financial stability.

Thus, after the elimination of multicollinearity, the integrated indicator of financial stability takes the following form:

$$\mathcal{J}^* = \alpha'_1 \sum K_i^{(I)} + \alpha'_2 \sum K_i^{(II)} + \alpha'_3 \sum K_i^{(III)} + \alpha'_4 \sum K_i^{(IV)}, \quad (5.7)$$

where $\alpha'_1, \alpha'_2, \alpha'_3, \alpha'_4$ – adjusted weighting factors of the first, second, third and fourth groups, respectively.

**System of indicators of simplified integrated assessment level
of financial stability**

Indicators	Generally accepted standards	Proposed standards
I. Degree of financial independence		
1.1 Coefficient of autonomy $K_1^{(I)}$	> 0,5	0,5–0,8
1.2 Rated capital structure ratio $K_3^{(I)}$	Increasing	> 1
1.3 Equity maneuverability ratio $K_4^{(I)}$	0,4–0,6	0,1–0,6
II. Liquidity and solvency		
2.1 Current liquidity ratio $K_2^{(II)}$	> 0,8	> 0,7
2.2 Absolute liquidity ratio (solvency) $K_3^{(II)}$	0,2–0,35	0,1–0,35
2.3 The ratio of receivables and payables $K_4^{(II)}$	> 2	1
III. Business activity		
3.1 Asset turnover ratio $K_1^{(III)}$	Increasing	> 0,8
IV. Profitability		
4.1. Return on assets ratio $K_1^{(IV)}$	Increasing	> 0,2
4.2. Coefficient of profitability of sales $K_2^{(IV)}$	Increasing	> 0,1

The recalculation of the level of financial stability of the surveyed enterprises showed that the discrepancy between the results obtained for the simplified and complete model is not significant, it means that the main positions of the ranked number of enterprises in terms of financial stability.

Thus, a simplified model can be used in the rapid analysis of the level of financial stability of enterprises. But for a more detailed and in-depth analysis to determine the main reasons for achieving a certain level of financial stability and for opportunities to develop financial recovery measures, it is necessary to use a complete model that is much more valuable for detailed internal analysis and forecasting factors that shape financial stability.

It should also be noted that considering and testing their own methods of calculating the integrated indicator, the authors of [4–20] did

not test the presence of multicollinearity in the set of proposed models. However, as the above analysis shows, this stage should be a mandatory and integral part of the development of any integrated model. It is worth noting the scientific work [7], in which the authors mention the method of principal components, the task of which is to linearly transform the associated factor features into a new set of independent random variables. However, this method was implemented by scientists only to determine the weights of indicators that characterize the components of anti-crisis potential.

The computer implementation of the developed model for assessing the level of financial stability of an agricultural enterprise was carried out on the basis of the Microsoft Office Excel spreadsheet package. The following stages were performed:

1. Preparation of template tables for input and output data.
2. Construction of a mathematical model using the above algorithms for calculating indicators.
3. Input of initial data and output of the obtained results in tabular form.
4. Modification of template tables for in-depth analysis using a complete model of financial stability assessment.

Thus, the developed software template allows a comprehensive assessment of the financial stability of the enterprise; it provides for a sequential transition from one subsystem to another. Each subsystem characterizes a separate aspect of the financial stability of the enterprise. The advantages of using the proposed method of assessing financial stability using economic and mathematical modeling are:

1. Universal character, as it can be used both for external (surface) assessment of the level of financial stability, and for detailed internal analysis, so it is possible to use different users.
2. Flexibility, which means that in each case it can be supplemented by other indicators or, conversely, simplified, which will not change or distort the principles of analysis.
3. Complexity, because the model takes into account all the main components that comprehensively characterize the concept of financial stability of the enterprise. Therefore, it is possible to take into account all the main factors that affect (or may affect) the level of financial stability.

The application of the model of financial stability assessment will allow:

- quantitative and qualitative analysis of individual components of the financial stability of the agricultural enterprise and its overall level, determining the extent of the impact of individual factors on the overall level of financial stability;
- make a conclusion about the level of financial stability, analyzing the degree of remoteness of the overall integrated indicator from the unit (standard);
- visually assess the actual level of each coefficient included in the diagnostic model in relation to its optimal values;
- determining the limits of changes in satisfactory indicators of financial stability (margin of safety), the level of financial stability of the enterprise (because the concept of financial stability may be temporary);
- to compare the enterprises of one branch with each other, in order to determine their rating and expediency of reorganization.

6. Economic and statistical analysis of the time series integrated indicator of financial stability

As known, a number of dynamics is called the sequence of values of a socio-economic indicator for certain periods of time [3]. Statistical assessment of the levels of a number of dynamics allows us to assess the main trends in the indicator for the period under study and to make a forecast for the near future on the basis of growth curves. The necessary stages of the analysis are: checking for abnormal levels; determining the presence of a trend; smoothing and smoothing of a number of dynamics; selection of trend model and calculation of its parameters by the method of least squares; study of the trend model for the adequacy, accuracy and presence of autocorrelation of residues; point and interval forecasting.

A review of the literature showed that according to the stages described above, the statistical study of time series for the integrated indicators proposed by the authors was not conducted. Several scientific studies provided only a visual assessment and formal analysis of changes in the values of the indicator over 5-6 years. It is worth noting the works [8; 12; 19], in which the authors attempted to conduct a correlation-regression analysis of the introduced integrated indicator and the corresponding forecast calculation for next year. However, in [8; 12] the whole analysis and conclusions were based only on four [12] or five [8] values of the time

series, which greatly calls into question their practical value and reliability of the forecast. A longer time interval (10 years) for the construction of trend models was used in [19]. The calculations were performed on the basis of the standard function “TREND” of the Microsoft Office Excel spreadsheet package. But no other econometric analysis of the studied time series was conducted by the authors.

In this regard, we consider it appropriate to acquaint the reader in detail with the basic methods and techniques of studying time series. Our further consideration will be focused mainly on the theoretical component of the econometric analysis of a number of dynamics. The result of the practical implementation of the above stages will be presented more concisely using the values of the integrated indicator of financial stability of the test enterprise for 10 years. Detailed data of practical calculations and their visualization can be found in [22]. In the future, the most successful agricultural enterprise of Vinnytsia district will be considered under the test enterprise.

1) Check for abnormal levels of a number of dynamics. It does not need to prove that the studied time series are not deterministic, but random. Therefore, abnormal values may appear among them. Such values may be due to technical errors or errors of the first kind. On the other hand, anomalous values may reflect real economic processes, such as rapid inflation, crises, changes in the vector of financial and economic activities of the enterprise and more; such anomalous values are errors of the second kind.

To detect anomalous levels of the time series y_1, y_2, \dots, y_n could be used the Irwin Test.

The calculation is carried out according to the formula

$$\lambda_i = \frac{y_i - y_{i-1}}{\sigma_y}, \quad i = 1, 2, \dots, n, \quad (6.1)$$

Note that in the case when the anomalous level of the time series is caused by an error of the technical order, it is replaced either by the corresponding value of the approximating curve, or the arithmetic mean of two adjacent levels of the series. Therefore, when abnormal levels are detected, the cause of their occurrence must also be determined. Checking for the presence of anomalous values of the above integrated indicator of financial stability of the test enterprise showed the presence of one anomalous level. A more

detailed analysis of the work of this enterprise allowed to establish the cause of its occurrence. As it turned out, this year capital investments were made in the form of expanding the main herd of cattle, which is related to the main specialization of the enterprise (breeding cattle). In particular, the increase in the financial stability of the enterprise in the following years convincingly demonstrated the relevance of such a strategic management decision.

2) Methods of studying a number of dynamics for the presence of a trend. If a number of dynamics show a long-term trend of changing economic indicators, then in this case they say that there is a trend. Thus, the trend is understood as a change that determines the general direction of development or the main trend of the time series. That is, the trend is a systematic (not accidental) component of long-term action.

The presence of a trend in the time series is checked by special methods. One of them is the method of series of characters, which is implemented by the following algorithm:

1. For the studied time series determine the sequence of signs based on the conditions

$$\delta_i = \begin{cases} +, & \text{when } y_{i+1} - y_i > 0, \\ -, & \text{when } y_{i+1} - y_i < 0. \end{cases} \quad (6.2)$$

in this case, if the adjacent values in the time series are the same, then take one of them.

2. Calculate the number of series $v(n)$. By series we mean a sequence of consecutive pros or cons, and one plus or one minus is considered a series.

3. Determine the length $l_{max}(n)$ of the longest series.

4. Find the number $l(n)$, that is determined by the following table.

Row length n	$n < 26$	$26 < n < 153$	$153 < n < 170$
Value $l(n)$	5	6	7

5. If at least one of the following two inequalities does not hold, then with a confidence level of 0.95 the hypothesis of no trend is rejected:

$$\begin{cases} v(n) > \left[\frac{1}{3} \cdot (2n-1) - 1,96 \cdot \sqrt{\frac{16n-29}{90}} \right]; \\ l_{max}(n) \leq l(n). \end{cases} \quad (6.3)$$

(Symbol $[a]$ means an integer part of a number a).

As calculations have shown, the first inequality was not fulfilled for the studied series of dynamics, therefore it was concluded that there is a trend of an integrated indicator of financial stability of the test enterprise.

Verification of the presence of a trend in the time series can be performed by other alternative methods, such as the method of checking the differences in the average levels or the Foster-Stewart method. It should be noted at once that the second method, the Foster-Stewart method, is more effective from the point of view of checking the presence of a trend, because it tests not only the mean value but also the variance. Here are the algorithms for implementing these methods.

The idea of the method of checking the differences of the middle levels is as follows:

1. Dynamic series y_1, y_2, \dots, y_n divide into two approximately equal parts in length n_1 and n_2 ($n_1 + n_2 = n$);

2. For each of these parts, calculate the average values \bar{y}_1, \bar{y}_2 and unbiased variances σ_1^2 and σ_2^2 ;

3. Using Fisher's test F_α we check the homogeneity of the variances of both parts of the series, where

$$F_\alpha = \begin{cases} \frac{\sigma_1^2}{\sigma_2^2}, & \text{when } \sigma_1^2 > \sigma_2^2; \\ \frac{\sigma_2^2}{\sigma_1^2}, & \text{when } \sigma_2^2 > \sigma_1^2. \end{cases} \quad (6.4)$$

The level of significance α is 0,1; 0,01 or 0,05. If the calculated value $F_\alpha^{(P)}$ is less than tabular $F_\alpha^{(T)}$, then the hypothesis of equality of variances is accepted and we proceed to check the presence or absence of a trend. If $F_\alpha^{(P)} \geq F_\alpha^{(T)}$, then the hypothesis of equality of variances is rejected and we conclude that this method does not answer the question of the presence or absence of a trend;

4. The hypothesis of no trend is tested using – Student's T Distribution
Here

$$t_p = \frac{|\bar{y}_1 - \bar{y}_2|}{\sigma \sqrt{\frac{1}{n_1} + \frac{1}{n_2}}}, \quad (6.5)$$

where σ – standard deviation of the difference of the means:

$$\sigma = \sqrt{\frac{(n_1 - 1)\sigma_1^2 + (n_2 - 1)\sigma_2^2}{n_1 + n_2 - 2}}. \quad (6.6)$$

If at the level of significance α , $t_p \leq t_\alpha$ (t_α – tabular value), then the hypothesis of no trend is accepted. If $t_p > t_\alpha$, then with probability $(1 - \alpha)$ we accept the hypothesis of the existence of a trend.

This method confirmed the previously concluded conclusions that the studied series has a tendency to develop.

Since two different methods of studying the trend of the integrated indicator of financial stability of the enterprise gave the same result, there is no need to use the Foster-Stewart method.

3) Mechanical smoothing of a number of dynamics. As a rule, forecasting of economic processes and phenomena on time series begins with construction of the schedule of a number of the chosen indicator. In order not to affect the forecast by random fluctuations of the series, smoothing and alignment of the series is carried out by various methods, which are divided into mechanical and analytical.

The simplest and most well-known methods of mechanical smoothing are the moving average method, the average growth rate method, the average growth method. These methods are more acceptable when the trend of the time series is close to linear.

Since the dynamics of a number of integrated indicators of financial stability of the test enterprise tends to increase first and then to saturation, it is advisable to use analytical curvilinear smoothing. For this purpose, the method of exponential smoothing was chosen, the essence of which is as follows.

If for a given dynamic series y_1, y_2, \dots, y_n the corresponding smoothed levels are denoted by S_i , $i = 1, 2, \dots, n$, then at exponential smoothing their values are calculated by the formula:

$$S_i = \alpha y_i + (1 - \alpha) S_{i-1}, \quad (6.7)$$

where α – smoothing parameter, $(1 - \alpha)$ – discount rate. It is easy to show that

$$S_i = \alpha \sum (1 - \alpha)^k y_{i-k} + (1 - \alpha)^i S_0, \quad (6.8)$$

this means that S_i it is the weighted average of all previous levels.

It is recommended to choose when processing economic time series $\alpha \in [0,1;0,3]$. In particular, the initial value S_0 accept or $S_0 = y_1$, or $S_0 = \frac{y_1 + y_2 + y_3}{3}$.

The advantage of this method in comparison with, for example, the moving average method is that during its use the first and last values of a series of dynamics are not lost. This is a very important argument in the study of small time series. Note also that the above technique was used in [22] for mechanical smoothing of the time series, which characterizes the integrated indicator of financial stability of the test enterprise, with the parameter.

4) Selection of the growth curve and calculation of its parameters. Growth curve models are typically used for economic forecasting. The set of analytical methods is to select a specific growth curve and determine its parameters. The growth curve is understood as a function that approximates this series of dynamics. The general stages of the forecast using growth curves are: the choice of the curve, the shape of which corresponds to the dynamics of the time series; finding the parameters of the selected curve; checking the curve for accuracy and adequacy of the studied process; calculation of point and interval forecasts.

Growth curves are usually selected from three classes of functions. The first class includes curves that are used to describe processes with monotonous development and no growth limits.

The second class includes curves that have a growth limit in the study period. Such curves are called saturation curves. If the saturation curves have an inflection point, they are referred to the third class. They are called S-shaped curves.

The integrated indicator of financial stability derived by us tends to saturate in its content. Therefore, the growth curve of this indicator can be taken as a curve of the type of Gompertz function, a logistic curve of the type of Pearl Reed function or a modified exponent.

Therefore, it is expedient to look for a model curve of growth of an indicator of financial stability of the test enterprise in the form:

$$\mathfrak{S} = \frac{1}{1 + a \cdot b^t}, \quad a > 0, \quad 0 < b < 1. \quad (6.9)$$

Parameters a and b, of which were found by the method of least squares after the conversion of the above equation to a linear form [22]:

$$\tilde{S} = \frac{1}{1 + 1,143 \cdot (0,877)^t}.$$

5) Assessment of the trend model for adequacy. The next stage of the analysis is the assessment of the obtained trend model for adequacy. That is, it is necessary to find out how correctly it reflects the studied economic process. This requirement is equivalent to the fact that the sequence of residues must have random fluctuations with a normal distribution law, zero mathematical expectations and the independence of their levels.

To study the randomness of deviations between theoretical and empirical values, we use one of such methods as the series method. This method uses a concept such as the median of the sample and is reduced to the following stages.

First, a number of residues u_i are ranked in ascending or descending order and the median is found $u_{me} = u_{(n+1)/2}$, when n – odd or $u_{me} = \frac{u_{n/2} + u_{(n/2)+1}}{2}$, when n – even. Then compare the initial series of residues with the median u_{me} . If at the same time $u_i > u_{me}$, then we put a sign “+”; if $u_i < u_{me}$, then we put a sign “-”; if $u_i = u_{me}$, then the value u_i is not taken into account.

The sequence of plus and minus that go in a row is called a series. If V – total number of series, and k_{\max} – the number of members of the longest series, then for the 5% level of significance we check the simultaneous implementation of the following two inequalities:

$$k_{\max} < [3,3 \cdot (\lg n + 1)]; \quad (6.10)$$

$$V > \left[\frac{1}{2} \cdot (n + 1 - 1,96 \cdot \sqrt{n - 1}) \right], \quad (6.11)$$

If at least one of the inequalities is not satisfied, then the hypothesis of randomness of the remnants of the time series is rejected and, therefore, the trend model is not adequate.

Calculations have shown that for the studied time series of the integrated indicator, both inequalities are satisfied, so it was concluded that the proposed trend model is adequate.

This result was also confirmed using the pivot point method. The idea of the method is as follows. A point u_i is called turning point if, $u_{i-1} < u_i > u_{i+1}$ or $u_{i-1} > u_i < u_{i+1}$.

If Π – total number of turning points, $\bar{\Pi}$ – their mathematical expectation, σ_{Π}^2 – their variance, where in case of random sampling of residues

$$\bar{\Pi} = \frac{2}{3}(n-2); \quad (6.12)$$

$$\sigma_{\Pi}^2 = \frac{(16n-29)}{90}, \quad (6.13)$$

then 5% of the significance of inequality

$$\Pi > \left[\bar{\Pi} - 1,96\sqrt{\sigma_{\Pi}^2} \right], \quad (6.14)$$

means that the trend model is adequate.

In practice, it is not always possible to immediately build a sufficiently high-quality forecasting model, so the stages of building trend models of economic dynamics can be performed repeatedly.

6) Check the presence of autocorrelation of residues. If the type of the trend function is chosen unsuccessfully, then the sequence of values of the residual series u_1, u_2, \dots, u_i may not have the property of independence. In this case, they say that there is an autocorrelation of errors.

The most common method of checking the presence of autocorrelation of residues is the Darbin-Watson test (DW):

$$d = DW = \frac{\sum_{i=2}^n (u_i - u_{i-1})^2}{\sum_{i=1}^n u_i^2}, \quad (6.15)$$

which can take values from the interval $[0; 4]$. (This criterion is sometimes called d -statistics).

If the residuals u_i are random variables normally distributed rather than auto correlated, then the DW values are near 2. With a positive autocorrelation of $DW < 2$, and with a negative $DW > 2$. For a given level of significance α , the number of observations n and the number of independent variables m in the table is the lower limit of DW_1 criterion and the upper limit of DW_2 .

If $DW_{fact.} < DW_1$, the residues have a positive autocorrelation. When $DW_{fact.} > DW_2$, we accept the hypothesis of no autocorrelation.

When $DW_1 < DW > DW_2$, then specific conclusions cannot be made and further research is needed, increasing the set of observations. It is

worth noting that the DW criterion is intended for small samples, which is important because the time series of the dynamics of economic phenomena are usually short.

You can also show the relationship between the autocorrelation coefficient ρ between adjacent residual members of the series and the DW criterion. Namely: if $\rho = 1$, then $DW = 0$; if $\rho = 0$, then $DW = 2$; if $\rho = -1$, then $DW = 4$. These ratios show that there are areas in which the Darbin-Watson test does not provide a specific answer about autocorrelation. The upper and lower limits of the DW criterion define the limits of this area for different sample sizes, a given level of significance, and a given number of explanatory variables.

Note that when $DW_{fact} > 2$, then we are talking about negative autocorrelation ($\rho < 0$). And since the critical values of the DW criterion are tabulated only for the case of positive autocorrelation, to draw a conclusion about the negative autocorrelation, it is necessary to compare with the critical value of the DW criterion is not calculated DW_{fact} and number $4 - DW_{fact}$.

For the indicator of financial stability $DW \approx 1,98$ we are considering, therefore, it was concluded that there is no autocorrelation of balances.

The magnitude of the deviations of the values of the levels of the series on the growth curve from the actual level also characterizes the accuracy of the trend model. To do this, it is necessary to calculate such statistical indicators as the standard deviation, σ , the mean relative error of the approximation, δ , the coefficient of convergence φ^2 , the coefficient of determination R^2 . The method of their calculation and the obtained actual values for the studied integrated indicator of financial stability of the test enterprise are given in [22]. Note also that these indicators allow you to choose from several alternative trend models the most accurate. In particular, the logistics curve turned out to be the most accurate for the introduced integrated indicator.

7) Forecasting the level of financial stability. The study of trend models of the dynamics of economic processes, as a rule, is carried out in order to predict the studied phenomena. Forecasting the time series is based on the method of extrapolation, the transfer of trends in the past to the future.

The application of the extrapolation method, using growth curves, is based on the following two assumptions: the time series does have a trend; the trend identified in the past will not change significantly in the future.

The forecast according to the trend model has two components: point and interval [21].

Point forecast is a numerical characteristic of the predicted process, which is determined by one number. It is obtained when in the equation of the trend model instead of time t we substitute the period of bias (predicted period) $t = n + 1, n + 2, \dots, n + \tau$. The length of the forecast period cannot be large and depends on the specifics of the forecast object, the time of its operation, the intensity of growth, the duration of the identified trends and patterns. In particular, the point forecast of the integrated indicator of financial condition, with a step of one year was carried out in [8; 12; 19]. Although, as noted above, the authors relied on a rather small time series (4-5 values) and did not conduct a general econometric analysis.

Interval forecast is a numerical characteristic, which is determined by two numbers – the ends of the interval, in which with a certain probability (confidence) should expect the appearance of the actual value of the projected economic and statistical indicator. From the economic point of view, the establishment of mathematically sound boundaries, gives an idea of the likely scenarios for the development of the phenomenon in the future, from the most possible pessimistic level to the most possible optimistic level. This approach is very important for the development of strategies for financial and economic activities of the enterprise. Unfortunately, a review of the literature has shown that the calculation of the interval forecast of the level of financial stability, the authors usually do not perform.

Finding the limits of confidence intervals in forecasting using growth curves is based on regression theory. These limits depend on the standard error of the forecast, the bias period, the number of time series levels and the significance level.

Here is an explanation of the use of general methods of interval forecasting in the time series (y_1, y_2, \dots, y_n) .

At the beginning it is necessary to determine the standard error $S_{\tilde{y}}$ of estimation of the forecasted indicator (y) by the formula:

$$S_{\tilde{y}} = \sqrt{\frac{\sum_{i=1}^n (y_i - \tilde{y}_i)^2}{n - m}}. \quad (6.16)$$

In the case of a straight-line trend, the confidence interval for y_p is:

$$y_p \in \left(\tilde{y}_{n+\tau} - S_{\tilde{y}} \cdot K ; \tilde{y}_{n+\tau} + S_{\tilde{y}} \cdot K \right), \quad (6.17)$$

where τ – period of prejudice; $\tilde{y}_{n+\tau}$ – point forecast according to the linear model on $(n + \tau)$ -period of time; $S_{\tilde{y}}$ – standard error in which $m = 2$;

$$K = t_{\alpha} \cdot \sqrt{1 + \frac{1}{n} + \frac{3 \cdot (n + 2\tau - 1)^2}{n(n^2 - 1)}};$$

t_{α} – tabular value of the Student’s criterion at the level of significance α .

To calculate the confidence interval of the forecast in the case of a straight-line trend, you can use the following formula:

$$y_p = \tilde{y}_{n+\tau} \pm t_{\alpha} \cdot S_{\tilde{y}} \cdot \sqrt{1 + \frac{1}{n} + \frac{(t_{\tau} - \bar{t})^2}{\sum (t_{\tau} - \bar{t})^2}}, \quad (6.18)$$

where t – serial number of the row level ($t = 1, 2, \dots, n$); summation is conducted for all observations; t_{τ} corresponds to the $(n + \tau)$ -th period of time, for which we make a forecast; \bar{t} – the time corresponding to the middle of the observation period for the original series.

If the beginning of the countdown is moved to the middle of the observation period,, $\bar{t} = 0$, then

$$y_{np} = \tilde{y}_{n+\tau} \pm t_{\alpha} \cdot S_{\tilde{y}} \cdot \sqrt{1 + \frac{1}{n} + \frac{t_{\tau}^2}{\sum t^2}}, \quad (6.19)$$

Similarly, confidence intervals can be found in the case of other growth curves that have a horizontal asymptote. In particular, for the logistics curve of the integrated indicator of financial stability introduced by us earlier

$$\mathfrak{S} = \frac{1}{1 + a \cdot b^t},$$

analysis involves reducing its appearance to linear $Y = B \cdot t + A$ by logarithm and further calculation of the confidence interval for the case of a linear trend in the new coordinates. The inverse transformation made it possible to determine the interval forecast of the integrated indicator of financial stability of the test economy with a confidence level of 0.95 [22]:

$$\tilde{\mathfrak{S}}_{np} = (0,663 ; 0,874).$$

Thus, the obtained interval value of the forecast level of financial stability indicates the existing potential in the test company to increase it (to 0.875), which is an optimistic scenario. However, there is also a pessimistic direction of a slight decrease in the value of the integrated

indicator (to 0.663). The reasons for such deviations may be changes in both internal and external environment of the enterprise.

Conclusions

The analysis provides an opportunity to summarize the following conclusions:

1. Economic and mathematical modeling of the assessment of financial stability of the enterprise allows you to quantify the relationship between the main factors that determine it and the magnitude of their impact.

2. The modern economic-mathematical model of the analysis of financial stability of the agricultural enterprise which combines interests of both internal, and external users of results of the analysis is developed in work. The development of integrated indicators took into account the determined weights of the components of financial stability and adjusted for agricultural enterprises normative values of each coefficient of the model.

3. The selected system of financial stability indicators was tested for multicollinearity. The study was conducted using the Farrar–Glauber test. After examining the closeness of the relationships between the indicators, in order to eliminate multicollinearity, ten indicators were removed from the model.

4. Comparing the results of the calculation of the integrated indicator according to the complete and simplified model, we note that the discrepancy between the obtained results is insignificant, the main positions of the ranked number of enterprises in terms of financial stability are preserved.

5. In the rapid analysis of the level of financial stability of enterprises it is necessary to use a simplified model, but for a more detailed and in-depth analysis to clarify the main reasons for achieving a certain level of financial stability and for opportunities to develop measures of financial recovery value for detailed internal analysis and forecasting the impact of factors that shape the financial stability of the enterprise.

6. The developed model for assessing financial stability can be attributed to a number of universal, as it has the following characteristics:

- the complexity of the study on the system of selected indicators;
- adaptive capabilities (can be used in the assessment of enterprises of any form of ownership and industry affiliation, adapted to the requirements of both internal and external users, both detailed and rapid analysis);

– continuity of the analytical process; – the possibility of deepening the analysis in selected areas that characterize the level of financial stability; – diversity (ability to assess financial stability at different times).

7. Based on the calculated values of the integrated indicator of financial stability of a private agricultural enterprise of Vinnytsia district, a number of dynamics were obtained. This series was studied for the presence of anomalous levels (Irwin method), for the presence of a trend (the method of signs and the method of checking the differences in mean levels).

8. In order to predict the level of financial stability of the analyzed enterprise exponential smoothing of the series (because the trend of the series is not close to linear).

9. The trend model of the growth curve in the analytical form is found, taking into account that the introduced indicator of financial stability for a given enterprise has a tendency of asymptotic saturation. The parameters of the curve were calculated by the method of least squares. The trend model was evaluated for adequacy and accuracy, point and interval forecasts were made for this agricultural enterprise.

References:

1. Ghnatienko, G. M., & Snytjuk, V. Je. (2008). *Ekspertni tekhnologiji pryjnattja rishenj* [Expert decision making technologies]. Kyiv: TOV "Maklaut", 444. (in Ukrainian)
2. Kucenko, D. M. (2021). Ekspertna ocinka u procesi diaghnostyky rivnja ekonomichnoji bezpeky pidpryjemstv iz metoju pryjnattja upravlinsjkykh rishenj [Expert assessment in the process of diagnosis of the level of economic security of enterprises for the purpose of making management decisions]. *Naukovyj visnyk Poltavskogo universytetu ekonomiky i torghivli. Serija «Ekonomichni nauky»* [Scientific Bulletin of Poltava University of Economics and Trade. A Series of "Economic Sciences"], 2–1(103), 7–11. DOI: <https://doi.org/10.37734/2409-6873-2021-2-1>
3. Dykha, M. V., & Moroz, V. S. (2016). *Ekonometrija: navchalnyj posibnyk* [Econometrics: a textbook]. Kyiv: «Centr uchbovoji literatury», 206. (in Ukrainian)
4. Zakabluk, Gh. O. (2018). Doslidzhennja dynamiky pokaznykiv finansovo-ekonomichnogo stanu promyslovykh pidpryjemstv na zasadakh integralnoho ocinjuvannja [Investigation of the dynamics of indicators of the financial and economic state of industrial enterprises on the basis of integral assessment]. *Investyciji: praktyka ta dosvid* [Investments: practice and experience]. 12, 36-41. Retrieved from: http://www.investplan.com.ua/pdf/12_2018/9.pdf
5. Lepetjukha, N. V., & Rudsjka, I. O. (2016). Integraljna ocinka efektyvnosti funkcionuvannja pidpryjemstva [The integral estimation of the enterprise functioning]. *Ghlobaljni ta nacionaljni problemy ekonomiky* [Global and National

Problems of Economics], 14, 424–429. Retrieved from: <http://global-national.in.ua/archive/14-2016/88.pdf>

6. Kovaljova, A. O., & Tanklevs'jka, N. S. (2020). Integhral'jna ocinka finansovo-ekonomichnogo stanu sil's'jkoghospodars'jkykh pidpryjemstv [Integrated assessment of financial and economic condition of agricultural enterprises]. *Strateghija ekonomichnogo rozvytku Ukrainy* [Strategy of economic development of Ukraine], 47, 86–105.

7. Piletska, S. T., & Korytko, T. Ju. (2018). Metodyka kompleksnoji ocinky antykrizovogo potencialu pidpryjemstva [Complex evaluation method of enterprises' anti-crisis potential]. *Ekonomika promyslovosti* [Economy of Industry], 3, 76–92.

8. Piletska, S., Korytko, T., & Tkachenko, Y. (2021). Modelj integhral'noji ocinky ekonomichnoji bezpeky pidpryjemstva [A Model of Integrated Assessment of the Enterprise Economic Security]. *Ekonomichnyj visnyk Donbasu* [Economic herald of the donbas], 3(65), 56–65. DOI: [https://doi.org/10.12958/1817-3772-2021-3\(65\)-56-65](https://doi.org/10.12958/1817-3772-2021-3(65)-56-65)

9. Yeletskykh, S., Svinarenko T., & Petrisheva, K. (2019). Metodychni pidkhody shhodo ocinjuvannja finansovo-ekonomichnoji bezpeky sub'jektiv pidpryjemnyckoji dijal'nosti iz vrakhuvannjam kryteriju finansovogho resursozberezhennja [Methodical approaches to assessing the financial and economic security of business entities, taking into account the criterion of financial resource saving]. *Ekonomichnyj visnyk Donbasu* [Economic herald of the donbas], 1(55), 94–102. DOI: [https://doi.org/10.12958/1817-3772-2019-1\(55\)-94-102](https://doi.org/10.12958/1817-3772-2019-1(55)-94-102)

10. Larikova, T. V. (2014). Osoblyvosti rozrakhunku integhral'noji ocinky finansovogho stanu sub'jektiv ghospodarjuvannja [The article is devoted feature of calculation of integral estimation of the financial state of subjects of menage]. *Naukovyj visnyk Kherson's'jkogho derzhavnogho universytetu. Ser.: Ekonomichni nauky* [Scientific Bulletin of Kherson State University. Series «Economic Sciences»], 6(1), 228–233. Retrieved from: http://www.ej.kherson.ua/journal/economic_06/56.pdf

11. Jacukh, O. O., & Zakharova, N. Ju. (2018). Finansovij stan pidpryjemstva ta metodyka jogho ocinky [Financial state of the enterprise and method of its evaluation]. *Vcheni zapysky Tavrijs'jkogho nacional'jnogho universytetu imeni VI Vernad's'jkogho. Serija: Ekonomika i upravlinnja* [Scientific notes of Taurida National V.I. Vernadsky University Series: Economy and Management], 29(68), no. 3, 173–180. Retrieved from: http://econ.vernadskyjournals.in.ua/journals/2018/29_68_3/35.pdf

12. Shiyko, V. I. (2018). Vdoskonalennja metodyky ocinjuvannja finansovoji stj'jivosti pidpryjemstv ghaluzi elektroenerghetyky [Improvement methodology for assessing the financial sustainability of power industry enterprises]. *Efektivna ekonomika* [Efficient economy], 5. Retrieved from: <http://www.economy.nayka.com.ua/?op=1&z=6347>

13. Lisnichuk, O. A., & Fadicieva, O. V. (2018). Systema pokaznykiv vykostannja finansovogho potencialu pidpryjemstva [The system of indicators of use of the financial potential of the enterprise]. *Infrastruktura rynku* [Market Infrastructure], 23, 287–292. Retrieved from: <http://www.market-infr.od.ua>

14. Vitvitska, U. Ja., & Shtym, Ju. V. (2018). Rejtyngnova ocinka finansovogho potencialu pidprijemstva [Rating assessment of the financial potential of the enterprise]. *Naukovyj visnyk Khersonskogo derzhavnogo universytetu. Ser.: Ekonomichni nauky* [Scientific Bulletin of Kherson State University. Series «Economic Sciences»], 30(4), 70–74. Retrieved from: http://www.ej.kherson.ua/journal/economic_30/4/19.pdf

15. Berzhanir, I. A., Vynnytska, O. A., & Gvozdie, N. I. (2018). Integralna ocinka finansovogho stanu pidprijemstva [Integral assessment of the financial state of an enterprise]. *Molodyj vchenyj* [Young Scientist], 2(2), 682–686. Retrieved from: <https://dspace.udpu.edu.ua/bitstream/6789/9043/1/Молодий%20вчений-254-258.pdf>

16. Khvostina, I. M. (2020). Volatyljnistj rjadiv dynamiky integhrovanykh pokaznykiv finansovogho stanu naftogazovykh pidprijemstv v umovakh ryzyku [Volatility of integrated indicators series of oil and gas enterprises' financial condition at risk]. *Aktualni problemy rozvytku ekonomiky regionu* [The actual problems of regional economy development], 2(16), 147–158. Retrieved from: <http://lib.pnu.edu.ua:8080/bitstream/123456789/10170/1/4582-Текст%20статті-10097-1-10-20201228.pdf>

17. Lobova, O. M., & Lomonosov, D. S. (2020). Suchasna praktyka ocinky finansovogho stanu pidprijemstv Ukrainy iz vykorystannjam nacionaljnykh modelej [Actual practice of assessing the financial condition of ukrainian enterprises by using national models]. *Ekonomika ta derzhava* [Economy and state], 3, 94–99. DOI: <https://doi.org/10.32702/2306-6806.2020.3.94>

18. Dubyns'ka, O. S. (2018). Vyznachenja typu finansovogho stanu pidprijemstva za kompleksnym integhralnym pokaznykom finansovoji zvitnosti [Determination as of the financial state of enterprise on complex integral index of financial reporting]. *Prychornomorsjki ekonomichni studiji* [Black Sea Economic Studies], 26(2), 136–141. Retrieved from: http://www.bses.in.ua/journals/2018/26_2_2018/30.pdf

19. Proskurovych, O. V., & Soroka, L. O. (2018). Ekonometrychne modeljuvannja finansovogho potencialu pidprijemstva [Econometric modeling of financial potential of the enterprise]. *Infrastruktura rynku* [Market Infrastructure], 19, 583–592. Retrieved from: http://www.market-infr.od.ua/journals/2018/19_2018_ukr/96.pdf

20. Andrenko, O. A., Mordovtsev, O. S., & Mordovtsev, S. M. (2020). Integralna ocinka finansovogho stanu ta kredytopromozhnosti komunaljnykh pidprijemstv Ukrainy [The Integral Assessment of the Financial Status and Creditworthiness of Communal Enterprises in Ukraine]. *Byznes Ynform* [Business Inform], 6(509), 116–122. Retrieved from: https://www.business-inform.net/article/?year=2020&abstract=2020_6_0_116_122&lang=en

21. Naiko, D. A., & Shevchuk, O. F. (2020). *Teorija jmovirnostej ta matematychna statystyka: navch. posib.* [Probability theory and mathematical statistics]. Vinnyca: VNAU, 382. (in Ukrainian)

22. Shevchuk, O. (2020). Financial stability of the enterprise. Forecast and adequacy of the mathematical model. *Slovak international scientific journal*, 2(39), 52–60.

**THEORETICAL AND METHODOLOGICAL
FUNDAMENTALS OF INTEGRAL ASSESSMENT
OF FINANCIAL SUSTAINABILITY OF THE ENTERPRISE**

Oleksandr Shevchuk¹

Olena Shevchuk²

DOI: <https://doi.org/10.30525/978-9934-26-193-0-15>

Abstract. The urgency of improving the financial security of Ukrainian enterprises in the current unstable economic conditions of their operation is one of the most important tasks of both the state and the business entities themselves. The search for opportunities to strengthen the financial situation should be facilitated by a systematic and objective analysis of the activities of any enterprise, the results of which allow you to respond quickly to changes in external and internal business environment, make sound management decisions on financial regulation.

The paper conducts a thorough study of existing theoretical and methodological approaches to determining the financial stability of the enterprise. It is proved that in determining the financial stability of the enterprise it is impossible to ignore social and environmental factors, so the definition of financial stability should cover all factors that shape it and the results of financially stable enterprise. The author's vision of the essence of the category "financial stability of the enterprise" was formed taking into account the above factors.

It is established that the financial stability of the enterprise plays an important role in ensuring expanded reproduction and profitability in the future. This is a complex category that studies the resource potential of the enterprise, its financial condition, dependence on the influence of internal

¹ Candidate of Physical and Mathematical Sciences,
Associate Professor of the Department of Mathematics, Physics and Computer Technologies,
Vinnytsia National Agrarian University, Ukraine

² Candidate of Economic Sciences,
Associate Professor of the Department of Computer Science and Economic Cybernetics,
Vinnytsia National Agrarian University, Ukraine;
Teacher of the Highest Category of the Separate Structural Subdivision
Technological and Industrial Professional College
Vinnytsia National Agrarian University, Ukraine

and external factors and the ability to ensure effective operation while maintaining solvency. Financial stability is a key guideline in business planning, the introduction of innovative technologies in the enterprise, in general, its indicators reflect the level of risk of operation. Financial stability is a key guideline in business planning, the introduction of innovative technologies in the enterprise, in general, its indicators reflect the level of risk of operation.

The main factors that determine the financial stability of the enterprise and risk management of its loss are considered. The existing approaches to the methodology of diagnostics, assessment and forecasting of financial stability of the enterprise are given.

It is proved that the assessment of the financial stability of an agricultural enterprise should be generalized, integrated and give an unambiguous answer about the level of financial stability of the enterprise. It must accumulate all the main aspects of the operation of the enterprise, ie take into account the importance of the most important indicators of financial and economic activities of economic entities.

It is emphasized that the integrated method of assessment is the most objective for such an analysis, as it allows you to quantify and evaluate the relationship between the main factors and predict their level in the future.

The study of existing models of assessment of financial stability of Ukrainian enterprises, indicated their disadvantages. Modern approaches to assessing the risk of bankruptcy using discriminant models are analyzed. The essence of the national model for assessing the financial condition of the beneficiary, its advantages and disadvantages are considered. The analysis of various methods of calculation of integrated indicators of the level of financial stability proposed by Ukrainian scientists is carried out. The urgency of the issue of developing a modern factor model of the integrated indicator, which needs to be improved and adapted to modern conditions of functioning of Ukrainian enterprises of the agricultural sector, is proved.

1. Introduction

Effective management of any enterprise is impossible without identifying risks that may adversely affect its future activities. It is not enough just to identify threats, it is necessary to make quality management decisions,

which are the basis for ensuring financial stability and continuity of the business entity.

The success of overcoming the crisis depends on the timely detection and use of effective methods to resolve it. The dynamics of the Ukrainian economy market requires further research to improve the scientific and methodological framework for identifying and assessing the financial crisis, its prevention and the formation of economic mechanisms and tools for business management in case of bankruptcy.

Financial and economic security is the main element and factor in creating economic security of the enterprise. Therefore, such concepts as “economic security” and “crisis management” are quite closely intertwined both substantively and functionally [1].

Anti-crisis management of the company begins with the birth of the idea of its creation. It is at this point that the initiator of entrepreneurial activity must be aware of the potential opportunities and threats that may arise during the operation of the firm [2].

The main characteristics of crisis management in modern conditions are:

- ensuring a stable financial condition of the enterprise in any economic, political or social changes;
- instant and effective response to changes in the external environment;
- the use of such management and financial mechanisms that would overcome the difficulties with the least losses for the company;
- timely diagnosis, which allows to identify and eliminate the negative effects of external and internal factors on the business entity;
- the choice of promising areas of development and strategic concept [3].

The essence of crisis management is expressed in the fact that crises can be: anticipate, expect, cause, accelerate, anticipate, postpone, mitigate, it is controlled, to a certain extent, the process to which you can and should prepare with special approaches, special knowledge, experience and art. The effectiveness of anti-crisis financial management of the enterprise is possible only when managers will be able to predict and forecast complex economic phenomena. Resources should be allocated according to anti-crisis priorities. The development of anti-crisis strategy should be based on the principles determined by the peculiarities of strategic planning, taking into account changes in business conditions and criteria for effective operation [4].

The main problems of management are low professionalism of managers and lack of practice of organizing teamwork for the result. For effective management and successful overcoming of crisis phenomena, it is necessary to increase the level of training, which is focused on the use of preventive rather than reactive methods of crisis management.

Thus, for the practical solution of problems of an estimation of efficiency of functioning of the enterprise careful studying of a situation on all its components is necessary. This allows only the method of integrated assessment of the effectiveness of the enterprise for all its groups of indicators. The system of indicators should be quite clear and reasonable, as it reflects the effectiveness of the enterprise from different angles and allows you to see what you need to pay attention to in the first place. Indicators and methods of evaluation should be specified depending on the activities of the enterprise and its industry.

2. Conceptual approaches to defining the essence financial stability of the enterprise

In the current conditions of agrarian crisis, a complete and objective analysis of the activities of agricultural enterprises is of particular importance, which allows to respond quickly to changes (especially negative) in both external and internal environment of the enterprise.

Therefore, the financial condition of economic entities requires constant assessment and control by managers of enterprises of all forms of ownership. It also attracts a lot of attention of Ukrainian economists, scientists who study the state, trends in agricultural production, the impact of various micro- and macro-level factors on the performance of agricultural producers.

One of the important factors for the successful operation of enterprises is the objective diagnosis and rapid assessment of financial condition, which allow timely development and implementation of effective measures to rehabilitate enterprises, prevent bankruptcy, increase their competitiveness and financial stability.

Only under conditions of stable financial condition of the enterprise can occupy a stable position in the region, effectively carry out modernization and reconstruction of production, to produce competitive products.

It should be noted that in the modern scientific literature such economic categories as “financial condition”, “financial stability” and “financial

stability” are not always unambiguously interpreted by the authors, and sometimes, their essence and interpretation differ significantly.

In particular, the concept of “financial stability” is often identified with “financial stability”, and in dictionary definitions there is an intertwining of the words “stable” and “sustainable”.

Also, most Ukrainian authors give a rather narrow and incomplete definition of financial stability, without revealing the essence of this complex and multifaceted economic category.

Thus, in [5] it is noted that the financial stability of the enterprise is characterized by the ratio of equity and borrowed capital, which cannot be agreed with, because only this ratio cannot conclude about the stable or unstable financial condition of the enterprise.

Petrovich Y.M. calls the financial stability of the firm’s independence from external borrowing. He believes that in order to assess the financial condition of a company, it is necessary to know how its assets are formed: from its own funds or from external liabilities. Therefore, an important analytical characteristic of the firm is its financial independence from external loan sources. According to this author, the stock of own funds is the stock of financial stability of the firm, provided that own funds exceed borrowed [6].

However, this definition is rather one-sided, as raising loan capital is a normal phenomenon and the opinion that the company’s refusal to use loans indicates its high financial stability is wrong, because raising loans within reasonable limits allows the company to use its financial resources more efficiently. resource. Thus, long-term loans help to expand the possibilities of faster renewal of material and technical base than can be done only at the expense of their own, often limited funds.

In particular, in [7] the author notes that financial stability is the result of activities that indicate the availability of the company’s own financial resources, the level of their use and directions of placement. But it is also impossible to agree with this definition, because the financial stability of the enterprise, although the result of activity, but characterizes the financial condition of the enterprise, on the other hand, using qualitative features that will provide the necessary conditions for enterprise activity.

In [8] it is noted that financial stability is a certain state of the enterprise’s calculations, which guarantees its constant solvency. This interpretation can

also be called incomplete and unclear, which blurs the line between the concepts of stability and solvency.

Instead, in the works of Korobov M.Ya., Lyakha L.M., Sveshnikova M.S., Savitsa G.V., Lakhtionova L.A. a fuller and more thorough definition of this category is proposed. In particular, Korobov M.Ya. characterizes financial stability as a state of financial resources in which the company would maintain the ability to continuously fulfill its financial obligations to its business partners, government, owners, employees. The author believes that companies are able to achieve stability of their finances only with strict adherence to the principles of commercial calculation, the main of which is the comparison of costs and results, obtaining maximum profits at minimum cost. If the parameters of the enterprise and the location of its financial resources meet the criteria of a positive characterization of the financial condition, it speaks of the financial stability of the enterprise [9].

In the scientific literature there are various conceptual theoretical and methodological approaches to determining the essence of financial stability of the enterprise, which can be divided into four groups:

- classic, which determines the financial stability in the narrow sense due to the excess of income of the entity over its costs;
- financial, based on which financial stability is identified with the solvency of the enterprise, so solvency is defined as one of its most important components, and financial stability is a necessary condition for sustainable and efficient development of the trading company;
- adaptive, in the context of which financial stability is equated to the ability of the enterprise to function, develop and adapt within a constantly changing environment;
- comprehensive, which summarizes the above approaches and determines that financial stability should be understood as the state and quality of financial resources of the entity, in which the company remains solvent, able to fully and timely fulfill its obligations under adverse effects internal and external factors of the environment and has a margin of safety, which ensures the preservation of the values of financial indicators at a stable level in the event of increasing negative factors and promotes rapid growth – in a favorable period of the economic cycle.

Gerega O.V. emphasizes such four components of the potential of financial and economic stability of enterprises as: (1) financial condition

and stability; (2) resource support; (3) resource efficiency; (4) capacity building and development [10].

In particular, according to the system-cost approach of S.M. Zhukevich [11, p. 208] the financial and economic stability of the enterprise is measured because of its ability to carry out systemic resistance to a changing environment, while maintaining an optimal functional structure that allows smooth and efficient engage in the main entrepreneurial activity. Therefore, the scientist quite rightly concludes that financial and economic stability is a necessary condition for financial stability and balance.

Some scientists highlight another type of enterprise resilience, such as the financial security limit [12]. It is determined by the presence of a certain reserve of financial strength achieved by the enterprise during the previous period of activity and protects against the effects of adverse destabilizing factors.

Such factors, in addition to purely economic, should include social – the level of wages, safety and labor protection, the state of social infrastructure of the village, etc., as well as the greening of enterprises.

Environmental management, development and implementation of measures to protect the environment, improve existing technological processes and take into account environmental factors as a result of the introduction of scientific and technological progress, should become mandatory elements of new management policy, especially in agriculture.

Scientists dealing with environmental issues have been emphasizing for many years that the characteristic feature of modern economic development is the global environmental crisis, the scale of which is growing rapidly in the context of scientific and technological progress. They note that the rate of environmental degradation is accelerating: 85% of the country's territory is polluted [13], 80% is affected by erosion, 17% of land has begun flooding, about 20% of land is contaminated with heavy metals. Great damage to the environment is caused by production and household waste.

Regarding agriculture, scientists note that in general only one in ten hectares of agricultural land has a normal ecological status [14].

Of course, the environmental strategy of the enterprise should not conflict with economic strategies. That is, when forming an economic strategy, it is necessary to take into account environmental factors. In particular, in the near future to introduce the obligation to measure the environmental

potential of each agricultural enterprise. Namely, the calculation of at least such basic indicators as the coefficient of resource conservation (by type of resource); coefficient of production output, certified according to environmental parameters; an indicator of the level of environmental pollution (possibly with their inclusion in the notes to the annual financial statements).

Based on the above considerations and priorities of today, in determining the financial stability of the enterprise cannot ignore social and environmental factors, ie the definition of financial stability should cover all factors that shape it and the results of financially stable enterprise.

Thus, based on the principles of complexity and balance of socio-economic and environmental activities, the financial stability of the enterprise should be considered as a state of accumulation, distribution and use of financial resources, in which the enterprise, freely maneuvering them, using the latest resource-saving and environmentally friendly continuous process of production and sale of products, its expansion and renewal, aimed at increasing the competitiveness of the enterprise and improving the socio-economic development of the team and the countryside.

3. The main factors determining the financial stability of the enterprise

The whole set of factors that affect the financial stability of the enterprise is divided into external and internal. External factors are factors that do not depend on the activities of the enterprise and at the same time have different strengths of influence on it. These are factors in the entity's external environment. Internal factors depend on the activities of the enterprise. The negative or positive impact of these factors is mainly determined by the literacy of management and marketing policy.

To achieve financial stability requires the optimal ratio of both internal and external factors.

Note that in the economic literature, the factor is understood as the cause, the driving force of a process that determines its nature (content) or its individual features. Factors are interrelated and interdependent in dynamic motion in both time and space [15]. If any of them fall out of the analysis, the assessment of the influence of other factors, as well as conclusions may be distorted and not relevant to the real situation.

Closely related, some factors affect the performance of enterprises in different ways, and therefore, it is very important to successfully assess and prevent the impact of these factors (especially – external). The effect of some factors may immediately worsen the financial condition of the enterprise (including unexpectedly lead to bankruptcy), others may have a gradual impact on the activities of the entity.

In countries with unstable economies, the financial condition of enterprises depends more on the influence of external factors that reflect the economic and political situation. For developed countries, the bankruptcy of enterprises is only a third due to external factors and two thirds due to internal. Therefore, in a relatively stable external environment, any business entity should pay more attention to the internal environment, analyze the factors that can be managed.

In modern economic literature, the external environment of the enterprise is considered as a complex multi-stage structure in which there are two main levels: macro- and micro-environment.

1) Macro environment (general environment), includes economic, political, social, legal, technological and environmental factors that reflect the socio-economic relations in the country and society as a whole.

2) Micro environment, covers the factors that have a direct impact on a particular enterprise. These are factors such as consumers, suppliers, creditors, competitors, employees, government agencies and others.

The macro environment determines the general conditions of economic activity, influences the factors of the microenvironment and through them – the development of the enterprise. Thus, various changes in the external environment will inevitably affect the financial results of the enterprise.

Therefore, it is especially important when planning any type of enterprise activity is a constant analysis of the external environment, forecasting its changes at least in the near future.

The classification of the main external factors that most affect the financial condition of the agricultural enterprise is shown in Figure 1.

Most often, methods of deduction and induction are used to assess the impact of external factors on the results of the enterprise; mathematical modeling; forecasting methods; expert methods and others. But, with the constant dynamic change of the environment, it is difficult to determine the most effective method of analysis, and therefore analysts have to combine

Chapter «Economic sciences»

several methods depending on the specifics of the studied factor and access to the necessary information.

External factors influencing the financial condition of an agricultural enterprise	Economic: the level of economic development of Ukraine; level of state regulation of agriculture; inflation rate in the country; disparity in prices for industrial and agricultural products; current taxation system; credit policy in the agro-industrial complex; effective consumer demand and income level; the degree of development of the market infrastructure of the agro-industrial complex, insurance services, foreign economic relations, the financial market of the agro-industrial complex; state of money turnover, forms of payment; level of Ukrainian and foreign competition; level of investment in agriculture.
	<i>Political</i> : political situation in Ukraine; the role and place of agriculture in the overall set of political programs of the government and the most influential parties.
	<i>Legal</i> : stability of legislation; level of antitrust policy; policy of state protectionism.
	<i>Technological and innovative</i> : the general level of scientific and technical condition of the country and type of activity; scientific support of technological processes in agro-industrial complex; development of innovative activity in the state.
	<i>Ecological</i> : depletion of land fertility, reduction of raw materials and material resources; climate change; pollution of territories with waste; land erosion; inefficient use of natural resources.
	<i>Socio-cultural</i> : living standards of the population (life traditions, cultural values of the people, mentality); working conditions; demographic processes in the country.
	<i>Soil and climatic</i> : seasonality of agricultural production; climate, meteorological conditions each year, natural disasters; relief, soil quality; set of water bodies.

Figure 1. External factors influencing the financial condition agricultural enterprise

But, unfortunately, only a small number of farm managers can assess the degree of risk of losing financial stability due to various external factors using mathematical methods, as collecting and processing large amounts of information needed for such analysis is difficult, especially in the absence of professional skills. Therefore, it is customary to trust more experience and intuition, or professionally trained professionals in these matters. It is more realistic to use an expert method of risk analysis in modern conditions.

Simultaneously with the analysis of external, it is impossible to underestimate the negative impact of internal factors on the life of the enterprise. Often, a company's financial problems are due to management incompetence, lack of management experience in dynamic market conditions, illiterate strategic planning, and so on. Due to inefficient management of the enterprise, significant errors can lead to deterioration of the financial condition of the entity, reduce its financial stability.

Internal factors affecting the financial stability of agricultural enterprises are shown in Figure 2.

Internal factors affecting the financial stability of agricultural enterprises	<i>Financial and economic</i> : the structure of financial capital of the enterprise; composition and structure of current assets and their turnover; price and cost of products, their dynamics; the ratio of costs and revenues of the enterprise, the dynamics of profitability; efficiency of profit distribution; size and dynamics of receivables and payables; the amount of reserve funds of the enterprise (the share of venture capital).
	<i>Production (operational)</i> : industry affiliation of the enterprise, local location; the size of the entity; specialization and concentration of production; state of technical equipment, level of mechanization and automation of production; innovation activity (possibility of using new production technologies at the enterprise); material and resource potential of the enterprise, efficient use of resources; organization of the production cycle, the relationship of all parts of production.
	<i>Commercial and sales</i> : development of marketing services at the enterprise, the effectiveness of marketing research; range and quality of products.
	<i>Entrepreneurial (managerial)</i> : system and methods of enterprise management (professional abilities and competence of management, focus on the laws of market economy); effectiveness of strategic planning; state of accounting; environmental factor in management decisions.
	<i>Social</i> : working conditions and living standards of employees; level of material stimulation of labor.

Figure 2. Internal factors influencing the financial condition agricultural enterprise

Note that there is a close connection and interdependence between the financial and sales aspects of the enterprise. Yes, financial success is usually the result of better performance. The growth of production, improving the quality and range of products, rhythmic production and shipment of products contributes to the timely and sometimes early receipt of funds

on the current account. This is one area of influence. However, there is another that is due to changes in the efficiency of production processes. For example, increasing production efficiency always reduces the need for resources and, consequently, reduces the cost of funds.

Normal financial activity, in turn, creates appropriate conditions for production, provides additional opportunities for its unplanned increase.

To analyze the internal environment of the enterprise (using financial statements), most authors suggest using the following basic methods:

1. Factor analysis – assessment of the impact of individual factors on the performance indicator, for example, changes in financial results due to changes in sales, cost and selling price.

2. Comparative analysis – temporal-spatial comparison of homogeneous indicators – between different enterprises, average data, optimal values, for different divisions of the enterprise and so on.

3. Horizontal analysis – a comparison of absolute and relative indicators in the dynamics (for example, determining the dynamics of changes in the solvency of the enterprise by year).

4. Vertical analysis – determination of the share of individual indicators in their totality (for example, the share of equity in the total amount of sources of financing of the enterprise).

5. Analysis of coefficients (relative indicators) – the ratio of individual reporting indicators.

From the listed methodical approaches, it is most expedient to use a method of coefficients. This is due to the fact that relative indicators more objectively characterize the trends of comparative indicators, and therefore more suitable for assessing trends and forecasting their change.

The methodological structure and sequence of formation of the potential of financial stability of the domestic enterprise is shown in Figure 3.

Thus, the uncertainty of market conditions, a number of negative and heterogeneous in nature economic and social factors in the synergistic effect cause the emergence of various and unexpected risks in the activities of modern economic entities. Their neutralization (minimization) to maintain business efficiency is considered in the context of management aspects of ensuring the sustainability of the enterprise. The financial stability management subsystem of an entity is present in any management concept.

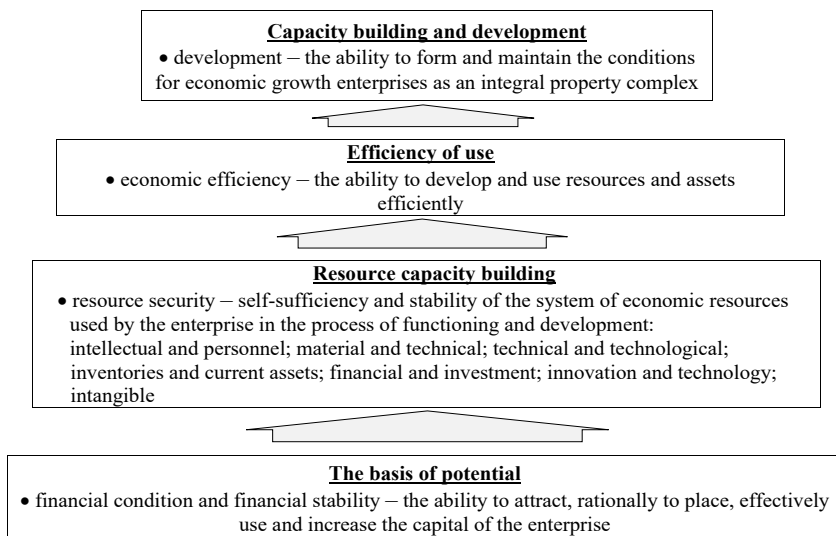

Figure 3. Conceptual structure and sequence of formation of potential of financial stability of the enterprise

4. Methodology for diagnosing, assessing and forecasting financial stability

According to the analysis of literature sources, there is currently no single methodology for determining the financial stability of the enterprise.

In addition, Ukrainian and foreign authors offer a large list of indicators with different methods of calculation and determination of the type of financial stability of the enterprise. But in general, we can identify two main approaches to the study of this issue:

The first approach involves the analysis of absolute indicators in the first stage and the analysis of relative indicators in the second stage of the study. A significant disadvantage of this most common approach is that scientists usually do not link these stages together, and the results of calculations of the relative indicators themselves are also unrelated.

The second approach is determined by the choice of a whole system of indicators, which is due to different interpretations of the essence of the

concept of financial stability. Obviously, the choice of a system of indicators is a determining factor in the analysis. Taking into account such factors as different sizes of farms and the impact of inflation, the main role in the study of financial stability is given to relative indicators.

The calculation of absolute indicators that characterize the degree of security of sources of their funding, with subsequent determination of the type of financial stability is quite common in economic sources and scientific articles [16–19].

The calculation method involves assessing the availability (surplus or deficit) of own funds; own and long-term borrowed funds and general funds according to the formulas:

$$\bar{D}_b = \text{own working capital} - \text{stocks};$$

$$\bar{D}_{b+d} = (\text{own working capital} + \text{long-term liabilities}) - \text{inventories};$$

$$\bar{D}_s = \text{the total value of sources} - \text{stocks}.$$

Based on the calculations, a three-component indicator is formed, which allows to determine the type of financial stability of the enterprise (Table 1):

$$\bar{S} = \left\{ S(\bar{D}_e), S(\bar{D}_{e+d}), S(\bar{D}_s) \right\},$$

as

$$S(x) = \begin{cases} 1, & \text{if } x \geq 0, \\ 0, & \text{if } x < 0. \end{cases}$$

Table 1

**Indicators of stocks with sources of their formation
by types of financial stability**

Indicators	Type of financial stability			
	Absolute financial stability	Normal financial stability	Unstable financial situation	Crisis financial situation
\bar{D}_e	≥ 0	< 0	< 0	< 0
\bar{D}_{e+d}	≥ 0	≥ 0	< 0	< 0
\bar{D}_s	≥ 0	≥ 0	≥ 0	< 0
Indicator of the type of financial stability	(1,1,1)	(0,1,1)	(0,0,1)	(0,0,0)

Absolute financial stability is characterized by the fact that all the company's reserves are covered by its own funds, the company is not dependent on external creditors, which is extremely rare. Moreover, absolute financial stability can hardly be considered ideal, as it means that the company's management does not use external sources of funding for its core business.

An enterprise with normal financial stability uses long-term borrowed funds to cover inventories in addition to its own funds. This type of inventory financing is "normal" from the point of view of financial management and is the most desirable for the company.

In the case of unstable (pre-crisis) financial condition, there is a violation of solvency, but there is a possibility of restoring the balance due to replenishment of sources of own funds, reduction of receivables, accelerating the turnover of inventories. Financial instability is considered normal (permissible) if the amount of short-term loans and borrowings raised to finance stocks does not exceed the total value of raw materials and finished products. Our calculations show that a rather small share (less than 10%) of agricultural enterprises in Vinnytsia have an unstable crisis, while the rest are on the verge of bankruptcy, as their cash, short-term securities and receivables do not cover even accounts payable and overdue loans.

However, it should be noted that the above method gives an idea only of the qualitative characteristics of the object of study, and the analyst cannot provide any quantitative conclusions, deepen the analysis of factors that shape the level of financial stability, develop recommendations.

Therefore, a more thorough study of financial stability should be based on the calculation and analysis of relative indicators. However, it should be noted the lack of a single methodology for assessing the financial stability of the enterprise. Ukrainian and foreign scientists offer a fairly large list of relative indicators with different calculation methods. But, as a rule, when assessing financial stability are limited to about 3-6 of the most common in theory and practice relative indicators. Only a small number of authors, considering the analysis of financial stability as the main and comprehensive stage of assessing the financial condition of the enterprise, structure the indicators of financial stability into separate groups.

Kalyshenko V.O., Moskalets K.M. [16], Yasinovska I.F. [17, p. 172] systematizing the methods of assessing financial stability, identified such

as: aggregate, coefficient, margin, point, balance, integral, factor and matrix. Each of them plays a role in the study of various aspects of financial stability. Thus, the aggregate method is the basis for determining the type of financial stability, margin – the margin of financial strength, matrix – calculating the structure and determining the quality of balance sheet assets and their financing adequacy, and integrated – the degree of financial stability.

Hryniv B.V. [18, p. 124–125] distinguishes the necessary and ancillary ratios of financial stability, including the main ratios: financial independence (autonomy, concentration of equity), maneuverability of equity, self-financing of current assets, liquidity, total coverage. Among the auxiliary, he singles out the coefficients: borrowing, investing, self-financing of stocks. The researcher emphasizes that additional coefficients should be used to avoid duplication only if the basic ones are clarified and supplemented.

Instead, Ionin E.E. [19, p. 17], pointing to the significant progress in the development of methodological foundations of research on financial stability, justifies the importance of analyzing financial indicators for early diagnosis of bankruptcy and the list of key indicators includes coefficients: financial independence, financial dependence, debt, liabilities and own capital, the ratio of equity and liabilities.

Thus, some scientists to assess the stability of the financial condition of the enterprise propose to use a system of indicators that characterize changes: the structure of capital of the enterprise, its location and sources of education; efficiency and intensity of its formation; solvency and creditworthiness; stock of its financial stability.

Izmaylova K.V., using absolute and relative indicators, assesses the financial stability of the enterprise according to the following criteria:

- the level of coverage of tangible working capital (stocks) with stable sources of funding;
- solvency of the enterprise (its potential ability to cover term liabilities with mobile assets);
- share of own or stable sources in total sources of financing [20].

For enterprises with financial crisis (the fourth type of financial stability), the following set of indicators of financial stability is recommended to assess the probability of bankruptcy: return on capital for “net profit”; product profitability; turnover of funds invested in current assets; coefficient of financial independence; liquidity (coverage ratio of current liabilities).

Based on these parameters, an integrated indicator is built, which is based on the comparison of each parameter for a long period of operation of the enterprise with the highest achievements of the enterprise on these parameters during the analyzed period.

Another method of financial stability analysis mentioned in the literature includes the following stages:

1. Analysis of the composition and placement of assets.

2. Analysis of the dynamics and structure of sources of financial resources (calculation of indicators of capital structure; calculation of indicators of the state of fixed assets).

3. Characteristics of the availability and structure of working capital.

4. Characteristics of the availability of working capital: determining the characteristics of the formation of inventories and costs; determination of indicators of providing stocks and costs with sources of their formation; identification of the type of financial situation: (calculation of indicators of working capital).

5. Analysis of accounts payable and receivable.

6. Analysis of solvency [21].

In our opinion, the above technique has a number of disadvantages:

– when analyzing the financial stability of agricultural enterprises, it is not so important for us to have an idea of the availability, structure of working capital, as indicators of efficiency of their use;

– there are no indicators of profitability (payback) of invested capital.

The literature offers two approaches to solving the problem of quantifying financial stability:

1. To assess the financial condition it is necessary to focus exclusively on data on sources of funding, capital. In this case, the assessment of the financial stability of the enterprise is carried out only on the basis of balance sheet liabilities.

2. To assess the financial stability of the enterprise it is necessary to analyze the relationship between assets and liabilities of the balance sheet, to monitor the use of funds.

And although the author considers the second approach more complete and justified, we cannot agree with the analysis of financial stability only using the balance sheet. After all, some authors rightly, in our opinion, supplement the above analysis with indicators of profitability (profitability) of enterprise capital.

Regarding the second approach to analysis, when assessing the optimal ratio of equity and borrowed capital of the enterprise, the indicators are divided into two blocks:

1. Capitalization ratios (which characterize the financial condition of the enterprise from the standpoint of the structure of sources of funds).
2. Coverage ratios (which characterize the financial stability from the standpoint of costs associated with the maintenance of external sources of borrowed funds).

Assessment of the level of financial and economic stability of the enterprise should: be generalized, integrated, give an unambiguous answer about the level of financial and economic stability of the enterprise in relation to comparison; accumulate all major aspects of the enterprise; take into account the possibility of short-term deterioration of certain indicators of financial and economic activity of the enterprise, which, however, are not characteristic of deteriorating stability of the enterprise – for example, implementation of marketing strategy, which involves the development of new markets.

5. Integral assessment of the financial stability of the enterprise

Given the fact that financial stability is a complex multifaceted concept that includes a large number of indicators with different critical limits and areas of optimization, it is advisable to use deterministic factor analysis, namely – an integrated method for diagnosing financial stability of economic entities.

The use of this technique allows to obtain more accurate results of the influence of factors compared to the methods of chain substitutions, absolute and relative differences and to prevent ambiguous assessment of the influence of factors, because in this case the results do not depend on the location of factors in the model. factors that decompose between them in proportion to their isolated impact on performance.

The advantages of this method are that it is not necessary to establish the order of change of factors, it is possible to study not only the relationship between individual factors and the overall result, but also the nature of inter factor relationships.

The main purpose of using the above method is to try to find the key factors that most influence (or have influenced) the level of financial

stability of agricultural enterprises in order to manage them. Under other conditions, the content of such an analysis is lost.

In economically developed countries, an integrated assessment of the level of financial stability of the enterprise (bankruptcy risk) is carried out on the basis of generally accepted methods [5; 6; 12; 15], among which the most famous are factor models of Altman, Beaver, Conan and Golder, Lusy, Toffler, Springgate. However, it should be noted that the use of these models, as shown by studies of Ukrainian economists [26; 29–32; 35] have no practical value and do not provide reliable results. Approbation of the above models at Ukrainian enterprises showed a significant inconsistency in the assessment of bankruptcy risk due to different methods of reflecting inflation factors, different capital structure, as well as due to differences in legislation and information base.

Ukrainian enterprises, especially agro-industrial ones, where there are specific features of the production cycle, need an individually developed modern model of assessing financial condition, including the probability of bankruptcy, which will take into account primarily the specifics of activities and national economy, legislation, etc. Such attempts were made by Ukrainian scientists in [22–26; 28–30; 32–35]. Note also that the two proposed models [22; 23] were developed by the authors specifically for the agro-industrial sector, which in this case is of particular value.

Consider these techniques in more detail:

1. The model of bankruptcy for agricultural enterprises proposed in [23] was developed on the basis of the well-known two-factor model of E. Altman. The author proposes to calculate the integrated indicator of bankruptcy risk according to the formula:

$$Z = -1,3496 - 0,6183 x_1 + 0,6867 x_2, \quad (1)$$

where: Z – integrated indicator of the risk of bankruptcy of agricultural enterprises; x_1 – coefficient of the working capital ratio (ratio of current assets to short-term liabilities); x_2 – coefficient of financial dependence (the ratio of borrowed and borrowed funds to total assets).

At $Z = 0$ we have the equation of the discriminant boundary. For companies where $Z = 0$ the probability of bankruptcy is 50%. If $Z < 0$, then the probability of bankruptcy is less than 50% and then decreases as Z decreases. If $Z > 0$, the probability of bankruptcy is more than 50% and increases with increasing Z .

However, the disadvantage of the two-factor model of bankruptcy is that it does not provide a comprehensive assessment of the financial condition of the enterprise, there may be significant deviations from the actual indicators. Although the authors propose to take into account the trend of changing profitability of sales, it should be noted that the methodology does not correlate the above additional indicator with the integrated.

2. Discriminant factor model for diagnosing the risk of bankruptcy of agricultural enterprises [22] is as follows:

$$Z = 0,111 x_1 + 13,239 x_2 + 1,676 x_3 + 0,515 x_4 + 3,80 x_5; \quad (2)$$

where x_1 – the share of working capital in the formation of current assets; x_2 – working capital per unit of currency; x_3 – turnover ratio of total capital; x_4 – return on assets of the enterprise, %; x_5 – coefficient of financial independence (share of equity in the total balance sheet currency).

The comparative constant is the number 8. If the value of Z is greater than 8, then the risk of bankruptcy is insignificant or non-existent. If the value of Z is less than 8, there is a risk of bankruptcy: from 8 to 5 – the risk is small, from 5 to 3 – medium, if the value is less than 3 – large, less than 1 – one hundred percent financial insolvency.

3. In [24] a universal discriminant function is proposed, which is calculated by the formula:

$$Z = 1,5 x_1 + 0,08 x_2 + 10 x_3 + 5 x_4 + 0,3 x_5 + 0,1 x_6; \quad (3)$$

where x_1 – cash-flow / commitment; x_2 – currency balance / commitment; x_3 – profit / currency balance; x_4 – profit / sales revenue; x_5 – production stocks / sales revenue; x_6 – sales revenue / currency balance.

The authors propose to interpret the obtained values of Z – indicator as follows: if $Z > 2$ then the company is considered financially stable and it is not threatened with bankruptcy; in the case when $1 < Z < 2$ – financial balance (financial stability) of the enterprise is violated, but under the condition of transition to anti-crisis management it is not threatened with bankruptcy; at $0 < Z < 2$ – the company is threatened with bankruptcy if it does not take remedial action and if $Z < 0$ – the company is semi-bankrupt.

4. The coefficient of probability of bankruptcy proposed in [25] is calculated by the formula:

$$Z = 8,38 x_1 + x_2 + 0,054 x_3 + 0,63 x_4; \quad (4)$$

where x_1 – working capital / average annual value of assets; x_2 – undivided profit / equity; x_3 – sales revenue / average annual value of assets; x_4 – undivided profit / general expenses. Interpretation of the obtained results is performed using Table 2.

Table 2

Determining the probability of bankruptcy of the enterprise according to the method

Bankruptcy risk, Z	Probability of bankruptcy, %
Less than 0	maximum (90 – 100)
from 0 to 0,18	high (60 – 80)
from 0,18 to 0,32	average (35 – 50)
from 0,32 to 0,42	low (15 – 20)
More than 0.42	minimal (до 10)

Source: [25]

5. In [26] the integrated indicator of financial stability of the enterprise is proposed to be calculated by the formulas:

$$Z = \alpha_1 + \alpha_2 + \alpha_3 \sqrt{x_1^{\alpha_1} \cdot x_2^{\alpha_2} \cdot x_3^{\alpha_3}}, \quad (5)$$

or

$$Z = \frac{\alpha_1 \cdot x_1 + \alpha_2 \cdot x_2 + \alpha_3 \cdot x_3}{\alpha_1 + \alpha_2 + \alpha_3}, \quad (6)$$

where x_1 – the level of solvency of the enterprise; x_2 – the level of financial independence of the enterprise; x_3 – level of asset quality; $\alpha_1, \alpha_2, \alpha_3$ – weighting factors of the relevant summary indicators.

In 2016, Ukraine issued an order of the Ministry of Finance “On approval of the Procedure for assessing the financial condition of a potential beneficiary of an investment project, the implementation of which is provided for financial self-sufficiency, as well as determining the type of collateral for servicing and repaying loans provided by international financial organizations. which will be carried out at the expense of the beneficiary”, which defines the procedure for assessing the financial stability (inverse concept of bankruptcy risk) of Ukrainian enterprises.

This legal document proposes the use of different models to assess the financial condition of enterprises depending on the industry and their size (Table 3).

Table 3

Models for calculating the integrated indicator of the financial condition of the beneficiary (large and medium enterprises)

№	Groups of economic activities	Formulas
1	Agriculture, forestry and fisheries	$Z = 1,3 K_3 + 0,03 K_4 + 0,001 K_5 + 0,61 K_6 + 0,75 K_7 + 2,5 K_8 + 0,04 K_9 - 0,2$
2	Manufacture of food products, beverages and tobacco	$Z = 0,035 K_1 + 0,04 K_2 + 2,7 K_3 + 0,1 K_6 + 1,1 K_7 + 1,2 K_8 + 0,05 K_9 - 0,8$
3	Manufacturing industry	$Z = 0,95 K_3 + 0,03 K_4 + 1,1 K_6 + 1,4 K_7 + 3,1 K_8 + 0,04 K_9 + 0,03 K_{10} - 0,45$
4	Mining and quarrying; processing industry; electricity and gas supply; water supply, sewerage	$Z = 0,025 K_1 + 1,9 K_3 + 0,45 K_6 + 1,5 K_8 + 0,03 K_9 - 0,5$
5	Construction	$Z = 0,02 K_1 + 1,7 K_3 + 0,01 K_4 + 0,3 K_6 + 0,4 K_7 + 2,9 K_8 - 0,1$
6	Wholesale and retail trade, repair of motor vehicles; temporary accommodation and catering	$Z = 1,03 K_3 + 0,001 K_4 + 0,16 K_6 + 0,6 K_7 + 2,9 K_8 + 0,08 K_9 - 0,14$
7	Transport, warehousing, postal and courier activities; telecommunications	$Z = 0,07 K_2 + 1,27 K_3 + 0,32 K_6 + 1,98 K_8 + 0,04 K_9 + 0,04 K_{10} - 0,15$
8	Financial and insurance activities (except banks)	$Z = 0,025 K_1 + 2,7 K_3 + 0,005 K_4 + 0,13 K_7 + 2,4 K_8 - 0,93$
9	Information and telecommunications; other operations and services	$Z = 0,03 K_1 + 0,9 K_3 + 0,01 K_4 + 0,002 K_5 + 0,15 K_6 + 0,5 K_7 + 2,9 K_8 - 0,05$

Source: [35]

Thus, two groups of enterprises were identified by size – large and small enterprises and nine groups by branches of economic activity of the company. The following ten financial ratios are used to build models: K_1 – coverage ratio (liquidity of the third degree); K_2 – intermediate coverage factor; K_3 – coefficient of financial independence; K_4 – ratio of non-current assets to equity; K_5 – return on equity; K_6 – coefficient of profitability of sales by financial results from operating activities (EBIT); K_7 – EBITDA margin; K_8 – return on assets for net income; K_9 – turnover ratio of current assets; K_{10} – turnover ratio of loan capital by financial results before tax, financial expenses and depreciation [27].

The financial ratios used to build models depend on the industry. Without exception, all models use the financial independence ratio and the

return on assets (ROA) ratio. These indicators are the basis for the financial analysis of any enterprise, as they reflect the efficiency of the company's resources (ROA) and the independence of the enterprise from the influence of creditors and debt capital, which characterizes the ability to cover own liabilities.

For each type of economic activity and size of the enterprise there is a corresponding table of interpretation of results.

The above-mentioned national system for assessing the financial condition of the entity eliminates national and sectoral factors influencing the quality of the results obtained (compared to classical models for assessing the risk of bankruptcy). However, the results obtained from the use of the national model do not fully reflect the real situation in the enterprise and do not allow to accurately predict its financial condition in the future.

As it turned out, in the course of the study, these methods give mixed results regarding the level of financial stability of agricultural enterprises in the Vinnytsia region. Comparing the actual data of calculations with the criteria for evaluating the integrated indicators for each method, a sharp contrast of the results of the analysis was obtained, and in some cases even their opposite. In particular, if according to the first method, it turned out that almost all enterprises in the region have a minimum (or average) probability of bankruptcy, and, consequently, financial stability at the appropriate level, the latter – all enterprises (except one) are on the brink of financial crisis bankruptcy. It should be noted that a similar crisis situation has been recorded before, when calculating absolute indicators and determining on their basis a three-component indicator of financial stability. Thus, the latter method better than others assesses the financial position of the enterprise, but it also has certain shortcomings:

1. Including theoretically in the summary indicators in addition to the coefficients of solvency and financial independence coefficients of the third group of indicators characterizing the level of asset quality (share of highly liquid assets, receivables quality ratio and net current assets ratio), the authors do not specify the values groups and weights that were determined by the expert method for the other two analytical areas. Which in turn complicates the practical use of this group of indicators in this method of calculating the integrated indicator of financial stability.

2. After calculating the actual values of integrated indicators, we do not get an answer to the question of interpretation of its negative values. In particular, further actions in the analysis are unknown when obtaining a negative (worst) result for all analyzed enterprises (when both actual and regulatory values are less than one), because the methodology does not detail the analysis of the results. Having received one ambiguous conclusion, which confirms the difficult financial situation, which the authors described as “the financial stability of the company is unsatisfactory”, it is impossible to compare different companies and analyze the degree of influence of key factors on the financial stability of each facility. The specifics of different types of economic activity and their segments are also not taken into account.

6. Conclusion

One of the important factors for the successful operation of enterprises is the rapid assessment of the level of financial stability, which allows timely development and implementation of effective measures for the rehabilitation of enterprises, prevent bankruptcy, increase their competitiveness. Methodological approaches to assessing the sustainability of Ukrainian enterprises are constantly being improved by scientists and transformed in accordance with the industry direction and modern economic conditions. However, in the economic literature there is a lack of specificity and unambiguity in the interpretation of some concepts that characterize the field of research, including vagueness in the definition of such categories as: “financial stability”, “stability”, “solvency”, “stable financial condition”.

Based on the principles of complexity and balance of socio-economic and environmental activities, financial stability of the enterprise should be considered as a state of accumulation, distribution and use of financial resources, in which the company, freely maneuvering them, using the latest resource-saving and environmentally friendly technologies continuous process of production and sale of products, its expansion and renewal, aimed at increasing the competitiveness of the enterprise and improving the socio-economic development of the team and the countryside.

Analyzing the financial stability of the enterprise, foreign and Ukrainian scientists use different approaches and techniques. Their diversity emphasizes the lack of a single methodology for assessing the

level of financial stability, which would objectively reflect the financial situation in the company. The analysis of various methods of calculating integrated indicators of financial stability, proposed by Ukrainian scientists, indicates that the issue of developing a modern factor model of the integrated indicator is quite relevant, needs improvement and adaptation to modern conditions of domestic agricultural enterprises. At the same time, this model should not only determine the level of financial stability of agricultural enterprises, but also provide an in-depth analysis of the formation of the results obtained; conduct research on inter factor relationships and determine the impact of each coefficient on the level of the aggregate indicator of both the individual analytical group and the overall integrated indicator.

Given the fact that the scientific literature offers a significant number of relative indicators of financial stability and a variety of approaches to determining its level, it is advisable to use the method of expert assessments, which will be discussed in the next section of the monograph.

References:

1. Azarenkova Gh. M., Bilomistnyj O. M., Bilomistna I. I. (2014). *Ekonomichna bezpeka: derzhava, rehion, pidpryjemstvo: monohrafija* [Economic security: state, region, enterprise: monograph] / za red. O. M. Trydida. Kyiv: UBS NBU, 192 p.
2. Shpak Nestor, Pyrogh Oljgha, Romanyshyn Marija (2015). *Ekonomichna stabiljnistj sub'jektiv ghospodarjuvannja v umovakh khaotychnogho rozvytku nacionaljnoji ekonomiky Ukrajiny: monohrafija* [Economic stability of business entities in the chaotic development of the national economy of Ukraine: a monograph]. Lviv: Lvivjska politehnika, 216 p.
3. Skibicjkyj O. M., Matvjejev V. V., Lisoval V. P. (2013). *Upravlinnja vyrobnyctvom. Menedzhment pidpryjemnyckoji dijalnosti: Navch. posibnyk* [Production management. Business management. Teaching manual] / Za redakciju L. I. Skibicjkoji. Kyiv: Kondor.
4. Azarenkova Gh. M., Bondarenko I. Ju., Azarenkov S. Gh. (2014). Zabezpechennja finansovoji bezpeky pidpryjemstva jak osnovy jogho efektyvnoji dijalnosti [Providing financial security of the enterprise as a basis for its effective activity]. *Finansovo-kredytna dijalnistj: problemy teoriji ta praktyky* [Financial and credit activities: problems of theory and practice], 1(16), 168–176. DOI: <https://doi.org/10.18371/fcapter.v1i16.28560>
5. *Ekonomika pidpryjemstva: Pidruchnyk* [Business Economics] / Za red. S.F. Pokropyvnogho (2001). 2-e vyd., pererob., dop. Kyiv: KNEU, 528 p.
6. Petrovyh J. M., Budishheva I. O., Ustinova I. Gh. (1996). *Ekonomika vyrobnychogho pidpryjemnyctva: Navch. posib.* [Economics of industrial entrepreneurship]. Lviv: Oskart, 416 p.

7. Mamontova N. A. (2000). Umovy zabezpechennja finansovoji stijkosti pidpryjemstv [Conditions for ensuring the financial stability of enterprises]. *Finansy Ukrainy* [Finance of Ukraine], no. 8, pp. 103–106.

8. Borysova V. A. (2000). Metodologichni osnovy analizu finansovogho stanu pidpryjemstv aghropromyslovogho vyrobnyctva [Methodological bases of the analysis of a financial condition of the enterprises of agro-industrial production]. *Finansy Ukrainy* [Finance of Ukraine], no. 10, pp. 66–68.

9. Korobov M. Ja. (2000). *Finansovo-ekonomichnyj analiz dijalnosti pidpryjemstv: Navch. posib.* [Financial and economic analysis of enterprises]. Kyiv: Znannya, 378 p.

10. Gheregha O. V. (2021). *Upravlinnja potencialom finansovo-ekonomichnoji stijkosti torhoveljnykh pidpryjemstv* [Management of the potential of financial and economic stability of commercial enterprises]: Dysertacija na zdobuttja naukovogho stupenja kandydata ekonomichnykh nauk za specialnistju 08.00.04 – ekonomika ta upravlinnja pidpryjemstvamy (za vydamy ekonomichnoji dijalnosti). Ljvivs'kyj torhoveljno-ekonomichnyj universytet, Lviv. Available at: http://www.lute.lviv.ua/fileadmin/www.lac.lviv.ua/data/pidrozdyly/Aspirantura/Rady/Spec_vchena_rada/Dysertacii/2021_04/Gerega_Diser.pdf

11. Zhukevych S. M. (2016). Diaghnostyka finansovo-ekonomichnoji stijkosti sub'jekta ghospodarjuvannja: konceptualnyj pidkhid [Diagnosis of finance and economic stability of business entity: conceptual approach]. *Innovacijna ekonomika* [Innovative economy], no. 5–6(63), pp. 206–211.

12. Krajnyk O. P., Klepkova Z. V. (2000). *Finansovyy menedzhment. Navchalnyj posibnyk* [Financial management]. Ljviv: Derzhavnyj universytet “Ljvivs'jka politehnika”. Kyiv: “Dakor”, 260 p.

13. Danylyshyn B. M. (2000). Stalyj rozvytok Ukrainy: realiji i problemy [Sustainable development of Ukraine: realities and problems]. *Problemy stalogho rozvytku Ukrainy* [Problems of sustainable development of Ukraine]. Kyiv: BMT, 402 p.

14. Trehobchuk V. M. (2000). Konceptualjni osnovy stalogho ta ekologichno zabezpechnogho rozvytku Ukrainy [Conceptual bases of sustainable and ecologically safe development of Ukraine]. *Problemy stalogho rozvytku Ukrainy* [Problems of sustainable development of Ukraine]. Kyiv: BMT, 402 p.

15. Cyghylyk I., Kropeljnycjka S. (2002). Ekonomichnyj analiz v systemi pidpryjemnyctva [Economic analysis in the business system]. *Ekonomika, finansy, pravo* [Economics. Finances. Law], no. 4, pp. 7–10.

16. Kalyschenko V. O., Moskalec K. M. *Oghljad ta uzagaljnennja metodychnykh pidkhodiv do ocinky finansovoji stijkosti pidpryjemstva* [Review and generalization of methodological approaches to assessing the financial stability of the enterprise]. Available at: <http://intkonf.org/kalishenko-vo-moskalets-km-oglyad-ta-uzagalnennya-metodichnih-pidhodiv-do-otsinki-finansovoyi-stijkosti-pidpriemstva/>

17. Jasinovs'jka I. F. (2016). Suchasni pidkhody do ocinky finansovoji stijkosti pidpryjemstv [Modern approaches to assessing the financial stability of enterprises]. *Jevropejsjki perspektivy* [European Perspectives], no. 2, pp. 169–175.

18. Ghryniv B. V. (2014). Dejaki problemy metodyky analizu finansovoji stijkosti pidpryjemstva [Some problems of the method of analysis of financial

stability of the enterprise]. *Visnyk Ljvivs'koho komercyjnoho akademiji. Serija: Ekonomichna* [Bulletin of the Lviv Commercial Academy. Series: Economic]. Lviv, no. 44, pp. 123–127.

19. Ionin E. E. (2016). Indykatory finansovoi stijkosti pidpryjemstva yak instrument rannjoi diagnostyky bankrutstva [Indicators of the enterprise as a tool for early diagnosis of bankruptcy of financial stability]. *Finansy, oblik, banky* [Finance, accounting, banks], no. 1(21), pp. 11–20.

20. Izmajlova K. V. (2001). *Finansovyj analiz* [Financial analysis]: Navch. posib. 2-ghe vyd., stereotyp. Kyiv: MAUP, 152 p.

21. Ljakh L. M. (2001). Pro metodyku vyznachennja koeficijentiv finansovoi stijkosti siljs'kogohospodars'kykh pidpryjemstv [On the method of determining the coefficients of financial stability of agricultural enterprises]. *Ekonomika APK*, no. 2, pp. 71–73.

22. Savycjka Gh. V. (2004). *Ekonomichnyj analiz dijalnosti pidpryjemstva* [Economic analysis of the enterprise]: Navch. posib. Kyiv: Znannja, 654 p.

23. *Fynansovoe polozhenye predpryjatja (ocenka, analiz, planyrovanje)* [Financial position of the enterprise (assessment, analysis, planning)]: Nauchno-metodycheskoe yzdanye (1999) / Pod red. d.e.n., professora A. V. Chupysa. Sumy: Yzdateljstvo "Unyversytetskaja knygha", 332 p.

24. Tereshhenko O. O. (2000). *Finansova sanacija ta bankrutstvo pidpryjemstv* [Financial position of the enterprise (assessment, analysis, planning)]: Navch. posibnyk. Kyiv: KNEU, 412 p.

25. Ghadzevych O. I. (2004). *Osnovy ekonomichnogho analizu i diagnostyky finansovo-ghospodars'koho dijalnosti pidpryjemstv* [Fundamentals of economic analysis and diagnosis of financial and economic activities of enterprises]: Navchalnyj posibnyk. Kyiv: Kondor, 180 p.

26. Benj T. Gh., Dovbnja S. B. (2002). Integhraljna ocinka finansovogho stanu pidpryjemstva [Integral assessment of enterprises' financial state with the help of cognitive diagnostic model of bankruptcy probability]. *Finansy Ukrainy* [Finance of Ukraine], no. 6, pp. 52–60.

27. Ministry of Finance of Ukraine (2016). Order "Approval of the Financial Condition of a Potential Beneficiary of an Investment Project Evaluation Procedure, the realization of which is envisaged on the terms of financial self-sufficiency, as well as determining the type of security for servicing and repayment of a loan provided at the expense of international financial organizations whose servicing will be carried out at the expense of the beneficiary". Available at: <https://zakon.rada.gov.ua/laws/show/z1095-16>

28. Zakabluk, Gh. O. (2018). Doslidzhennja dynamiky pokaznykiv finansovo-ekonomichnogho stanu promyslovykh pidpryjemstv na zasadakh integhralnogho ocinjuvannja [Investigation of the dynamics of indicators of the financial and economic state of industrial enterprises on the basis of integral assessment]. *Investyciji: praktyka ta dosvid* [Investments: practice and experience], 12, 36–41. Available at: http://www.investplan.com.ua/pdf/12_2018/9.pdf

29. Lepetjukha, N. V., & Ruds'jka, I. O. (2016). Integhraljna ocinka efektyvnosti funkcionuvannja pidpryjemstva [The integral estimation of the enterprise

functioning]. *Ghlobaljni ta nacionaljni problemy ekonomiky* [Global and National Problems of Economics], 14, 424–429. Available at: <http://global-national.in.ua/archive/14-2016/88.pdf>

30. Kovaljova, A. O., & Tanklevsjska, N. S. (2020). Integhraljna ocinka finansovo-ekonomichnogho stanu silijskogospodarsjkykh pidpryjemstv [Integrated assessment of financial and economic condition of agricultural enterprises]. *Strateghija ekonomichnogho rozvytku Ukrainy* [Strategy of economic development of Ukraine], 47, 86–105.

31. Piletska, S. T., & Korytko, T. Ju. (2018). Metodyka kompleksnoji ocinky antykryzovogho potencialu pidpryjemstva [Complex evaluation method of enterprises' anti-crisis potential]. *Ekonomika promyslovosti* [Economy of Industry], 3, 76–92.

32. Piletska, S., Korytko, T., & Tkachenko, Y. (2021). Modelj integhralnoji ocinky ekonomichnoji bezpeky pidpryjemstva [A Model of Integrated Assessment of the Enterprise Economic Security]. *Ekonomichnyj visnyk Donbasu* [Economic herald of the donbas], 3(65), 56–65. DOI: [https://doi.org/10.12958/1817-3772-2021-3\(65\)-56-65](https://doi.org/10.12958/1817-3772-2021-3(65)-56-65)

33. Yeletskykh, S., SvinarenkoT., & Petrisheva, K. (2019). Metodychni pidkhody shhodo ocinjuvannja finansovo-ekonomichnoji bezpeky sub'jektiv pidpryjemnyckoji dijalnosti iz vrakhuvannjam kryteriju finansovogho resursozberezhennja [Methodical approaches to assessing the financial and economic security of business entities, taking into account the criterion of financial resource saving]. *Ekonomichnyj visnyk Donbasu* [Economic herald of the donbas], 1(55), 94–102. DOI: [https://doi.org/10.12958/1817-3772-2019-1\(55\)-94-102](https://doi.org/10.12958/1817-3772-2019-1(55)-94-102)

Khvostina, I. M. (2020). Volatyljnistj rjadiv dynamiky integhrovanykh pokaznykiv finansovogho stanu naftoghazovykh pidpryjemstv v umovakh ryzyku [Volatility of integrated indicators series of oil and gas enterprises' financial condition at risk]. *Aktualni problemy rozvytku ekonomiky regionu* [The actual problems of regional economy development], 2(16), 147–158. Available at: <http://lib.pnu.edu.ua:8080/bitstream/123456789/10170/1/4582-Текст%20статті-10097-1-10-20201228.pdf>

34. Lobova O. M., Lomonosov D. S. (2020). Suchasna praktyka ocinky finansovogho stanu pidpryjemstv Ukrainy iz vykorystannjam nacionaljnykh modelej [Actual practice of assessing the financial condition of ukrainian enterprises by using national models]. *Ekonomika ta derzhava* [Economy and state], 3, 94–99. DOI: <https://doi.org/10.32702/2306-6806.2020.3.94>

CHAPTER «TECHNICAL SCIENCES»

VISCOSITY AND THERMAL CONDUCTIVITY OF RUBIDIUM AND CESIUM IN THE GAS PHASE

Viktor Dzis¹

Olena Dyachynska²

DOI: <https://doi.org/10.30525/978-9934-26-193-0-16>

Abstract. An experimental installation has been developed to study the viscosity of alkali metal vapor in a wide range of high (up to 2000 K) temperatures, which implements the method from a viscometer with an annular channel. The design of the viscometer of the measuring cell makes it possible to directly measure the temperature of the working element of the viscometer. This provides an accurate determination of the temperature of the investigated alkali metal vapor in the working gap.

The original method of stabilization of the steam generator operation mode was applied, which allowed to ensure the stationary flow of the investigated alkali metal vapor in the working element of the viscometer. Distinctive features of the created installation are high stability of modes of its work and considerable resource.

An experimental study of the viscosity of rubidium and cesium in the gas phase was carried out by the method of a viscometer with an annular channel at the following values of the state parameters:

for cesium $T = 900 \dots 1770$ K, $P = 12 \dots 135$ kPa;

for rubidium $T = 990 \dots 1750$ K, $P = 39 \dots 135$ kPa.

Most of the experimental data obtained are in the temperature range above 1200 K. The average error of the experimental data is 3%. From the experimental data on the viscosity of cesium and rubidium in the gas phase, the values of the effective cross sections of the «atom-atom» collisions and

¹ Candidate of Technical Sciences,

Associate Professor of the Department of Mathematics, Physics and Computer Technologies,
Vinnytsia National Agrarian University, Ukraine

² Assistant of the Department of Mathematics, Physics and Computer Technologies,
Vinnytsia National Agrarian University, Ukraine

the relative cross-sections of the «atom-molecule» collisions were obtained. Calculated equations and tables of viscosity and thermal conductivity of cesium and rubidium vapor in the temperature range 700-2000 K and pressures 1-1500 kPa, including the saturation line, have been developed.

An experimental study of the viscosity of rubidium and cesium vapor at high temperatures have been conducted with implementation of the method from a viscosimeter with an annular channel. From the experimental data on the viscosity of cesium and rubidium in the gas phase, the values of the effective cross sections of the «atom-atom» collisions and the relative cross-sections of the «atom-molecule» collisions were obtained. Calculated equations and tables of viscosity and thermal conductivity in a wide range of temperatures and pressures have been developed.

1. Introduction

The alkali metal vapor in the state parameters $T = 700... 2000\text{K}$, $P = 1... 1500\text{ kPa}$ available for experimental study consists of atomic and molecular components with a rather low concentration of clusters and charged particles. The concentration of diatomic molecules in a pair is unequivocally determined by the parameters of its state: pressure and temperature. Thus, the viscosity and thermal conductivity of alkali metals in the gas phase in the selected temperature range can be considered as the processes of transfer in a binary mixture of rarefied ideal gases, taking into account the course of dissociation reactions.

Theoretical methods for calculating the viscosity and thermal conductivity of alkali metal vapors are significantly limited due to the lack of sufficiently accurate data on the interaction potentials of «atom-atom», «atom-molecule» and «molecule-molecule». The experiment is still the only source of information necessary for the transfer coefficients of alkali metal vapor.

Experimental studies of alkali metal vapor transfer processes are associated with difficulties in the implementation of experimental methods due to the high chemical activity of alkali metals at high temperatures, and with the study of cesium there appear a number of additional complications associated with its specific properties. In real conditions of the experiment, the processes associated with thermoelectron emission and surface ionization, photoeffect and photoionization can occur, at high temperatures

the number of inelastic collisions of atoms increases, and at high pressures the reality of gases manifests itself. However, it is possible to create such experimental conditions in which the listed effects are not noticeable, and to identify the vapor state region in which the ideal gas model can be used to describe the transfer phenomena, in which molecule formation and decay reactions take place, which allows to apply the results of strict kinetic Chapman-Jensky and Hirschfelder-Brokau theories [1] for a mixture of reacting gases and its specific application for alkali metal vapors [2; 3].

The aim of this work is to establish the dependence of viscosity and thermal conductivity of rubidium and cesium in the gas phase on temperature and pressure and to construct calculation equations and tables of viscosity and thermal conductivity in a wide range of temperatures and pressures.

2. Research method

Experimental methods previously used to study the vapor viscosity of alkali metals, except for the method of a viscometer with an annular channel [5; 6; 8], are limited to a temperature of 1200-1300 K.

The annular-channel viscometer method allows experiments with alkali metal vapors at temperatures well above 1200 K. It was first used by V.I. Dolgov [8] to study the viscosity of lithium vapor. In [8] the advantage of this method over the previously used methods of measuring the viscosity of alkali metal vapors is shown, its disadvantages are considered. I.F. Stepanenko [5] improved this method, developed the original design of the measuring cell. In [6] the flow of alkali metal vapor in the working gap of the viscometer was analyzed, the method of calibration of the measuring element and measurement of condensate flow was improved, accuracy was significantly increased, lithium vapor viscosity $T = 1595 \dots 1983$ K, $P = 15 \dots 107$ kPa and sodium at $T = 1109 \dots 1524$ K, $P = 12 \dots 100$ kPa was researched.

At temperatures up to 2000 K and pressures of 1 ... 1500 kPa, alkali metals in the gas phase can be considered as a binary gas mixture consisting of atoms and diatomic molecules, between which dissociation reactions take place.

Theoretical methods for calculating the viscosity and thermal conductivity of alkali metal vapor as a reactive gas mixture of atoms and diatomic molecules are significantly limited due to the lack of accurate

data on the potentials of «atom-molecule» and «molecule-molecule» interaction. Existing calculation methods are connected with a number of simplifications that reduce the results of such calculations to the level of estimates. The experiment is still the only source of information necessary for the transfer coefficients of alkali metal vapor. Theory [2; 3] makes it possible to obtain the values of the relative cross sections of the atom-atom and atom-molecule collisions from experimental viscosity data and, using them, to calculate the coefficients of thermal conductivity and vapor viscosity in a wide range of state parameters.

One of the most convenient experimental methods for studying the viscosity of alkali metal vapor is the annular-channel viscometer method. In such a viscometer, an alkali metal vapor flows through a channel between two coaxial cylinders. This design of the viscometer makes it possible, in relation to classical capillary methods, to reduce by an order of magnitude the linear dimensions of the working element, which ensures the stability of the vapor temperature and the stability of its composition along the working element.

An experimental installation for the study of the viscosity of alkali metals was developed on the basis of [5; 6; 8]. It is a closed circulation circuit, the high-temperature part of which is made of niobium-zirconium alloy, and the low-temperature part of stainless steel. The measuring element of the cell is an annular channel formed by two coaxial cylinders. The measuring cell is equipped with a drip device that provides high stability of the steam generator. The design of the viscometer allows you to directly measure the temperature of the inner part of the measuring element of the viscometer, which improves the accuracy of determining the temperature of steam in the annular gap of the cell.

Schematic diagram of the installation is shown in Figure 1.

The measuring cell of the installation (elements 1-7) is placed in the vacuum chamber 8. The cell consists of an evaporator I, a viscometer (elements 2, 3), a superheater 4, a pressure tube 5, a refrigerator 6, a drip device 7. The working element of the viscometer is an annular gap formed between the inner surface of the pipe 2 and the cylindrical insert 3. The temperature of the evaporator is maintained by the heater 9, and of the viscometer by the heater 10. The cell has a system of thermal screens II, consisting of two packages of end and three packages of radial screens. The

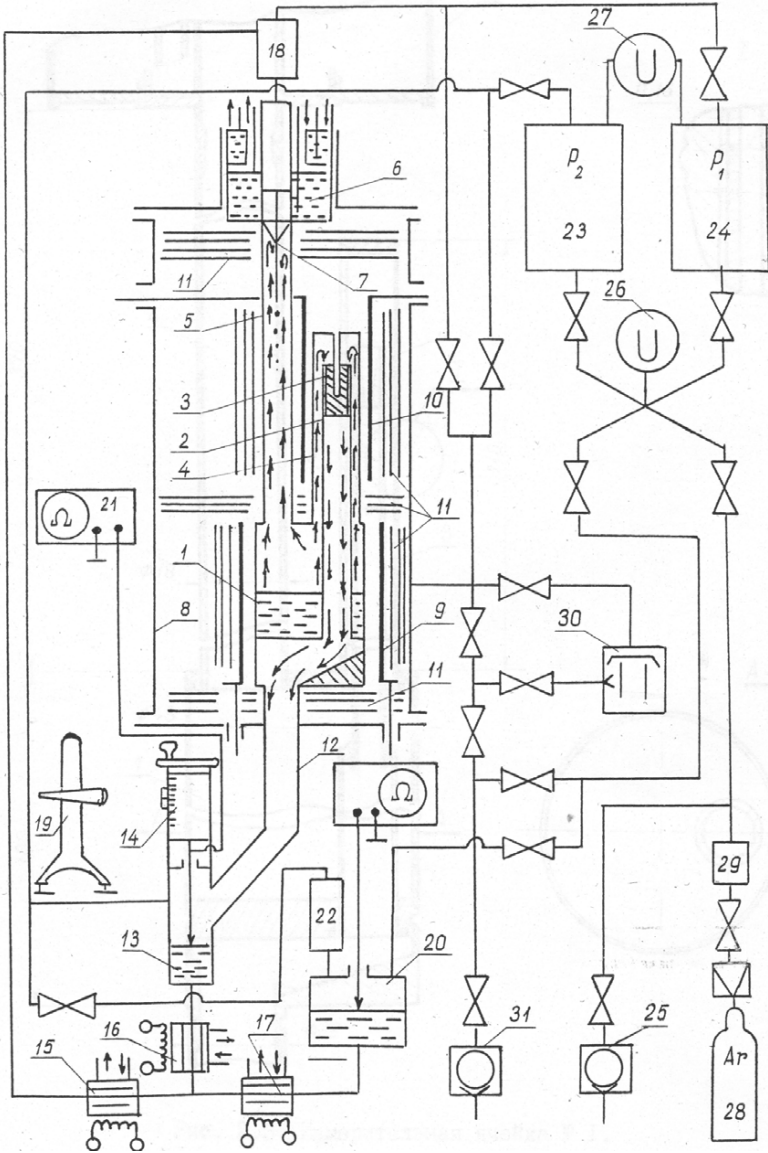

Figure 1. Schematic diagram of the installation

upper and lower flanges of the vacuum chamber are connected to its body by means of a ditch – wedge connection. A condensate collection line 12 is welded to the lower flange of the chamber. A measuring cell is connected to its upper part by means of a vacuum connection «ball-cone», and a flow meter 13 is attached to the lower part of the cell, equipped with a device for fixing small movements of the flowmeter needle 14.

The flowmeter is connected to a system of liquid taps 15, 16, 17, by means of which the drain vessel 20 is connected to the flowmeter or ballast vessel 18. The displacement of the flowmeter needle is measured by a catheter 19, the moment of contact with the needle of the surface of the liquid metal in the flowmeter is measured by the value of the electrical resistance resistance «needle – flow meter». The drain vessel is connected to the filling device 22 through the pipe 31.

The housing, upper and lower flanges of the vacuum chamber are cooled by water. The «ball-cone» vacuum connection of the cell is cooled by means of a copper heat sink connected to the lower flange of the chamber.

The gas system consists of receivers 23, 24 and a high-vacuum pump 25. It serves to create the working pressure in the measuring cell and the pressure drop in the area of the viscometer. The argon pressure in the system is measured by a mercury U-like manometer 26, and the pressure drop between the receivers by an oil U-like manometer 27, the atmospheric pressure is measured by a mercury manometer (ICB type – 1).

Argon in the gas system of the installation comes from the cylinder 28 through the gas filter 29 filled with liquid alkali metal (respectively Cs or Rb).

High vacuum $P \approx 1 \cdot 10^6$ millimetres of mercury column) in the chamber 8, and if necessary in the receivers 23, 24 is created by a high-vacuum system consisting of a vacuum diffusion pump 30 and a vacuum mechanical pump 31.

The measuring cell, gas and vacuum systems are interconnected by stainless steel pipes and switched together by means of vacuum valves.

Electric heaters 9, 10 are made of molybdenum foil, powered by AC mains through low-voltage transformers, the primary voltage of which is set by a voltage regulator.

The principle of operation of the installation is as follows: the investigated metal vapor comes from the steam generator to the steam heater, passes

through the measuring element of the viscometer, condenses in the cold part of the condensate collection line and is collected in the flow meter. The pressure drop on the measuring element is created through the intermediate inert gas – argon.

The viscosity of the vapor is determined by the mass flow rate of the alkali metal through the annular channel at a given value of the pressure drop across the measuring element of the viscometer. To do this, the installation must ensure high stationary flow of steam in the annular channel at constant values of temperature and pressure of the experiment.

Two measuring cells (Figures 2, 3), which differ in the design of the viscometer, were used in the work. The measuring cell consists of an evaporator 1, a viscometer (elements 2, 5), a superheater 3, a pressure pipe 4, a refrigerator 6 with a drip device 7.

The working element of the viscometer is an annular channel formed between the inner surface of the pipeline 2 and the cylindrical insert 5. The dimensions of the annular channels of the cells are given in table 1.

Table 1

Cell	№ 1	№ 2
Internal diameter of a pipe, mm	$5,00 \pm 0,01$	$6,05 \pm 0,01$
Diameter of a cylindrical insert, mm	$4,68 \pm 0,01$	$5,73 \pm 0,01$
Length of a working site, mm	$26,0 \pm 0,1$	$32,0 \pm 0,01$

The cylindrical insert of the cell № 2 differs from the cylindrical insert of the cell № 1 (Figures 4, 5) by the geometry of the inlet section, the method of attachment and has a recess for installing the thermocouple.

The cylindrical insert of the cell № 1 was inserted into the tube 2, the upper struts were welded to its ends. In the cell № 2 the cylindrical insert was inserted into the pipe 2 and welded to the end of the pipe 3, the upper and lower locking protrusions slide freely on the surface of the pipe.

All parts of the measuring cell, except for the refrigerator and the needle of the drip device, are made of niobium alloy NbCU and are interconnected by electron beam welding.

The body of the refrigerator is made of stainless steel, the stainless steel-niobium connection is made in the cold zone ($T < 320 \dots 400$ K), which eliminates mechanical loads on the welded joint due to thermal expansion.

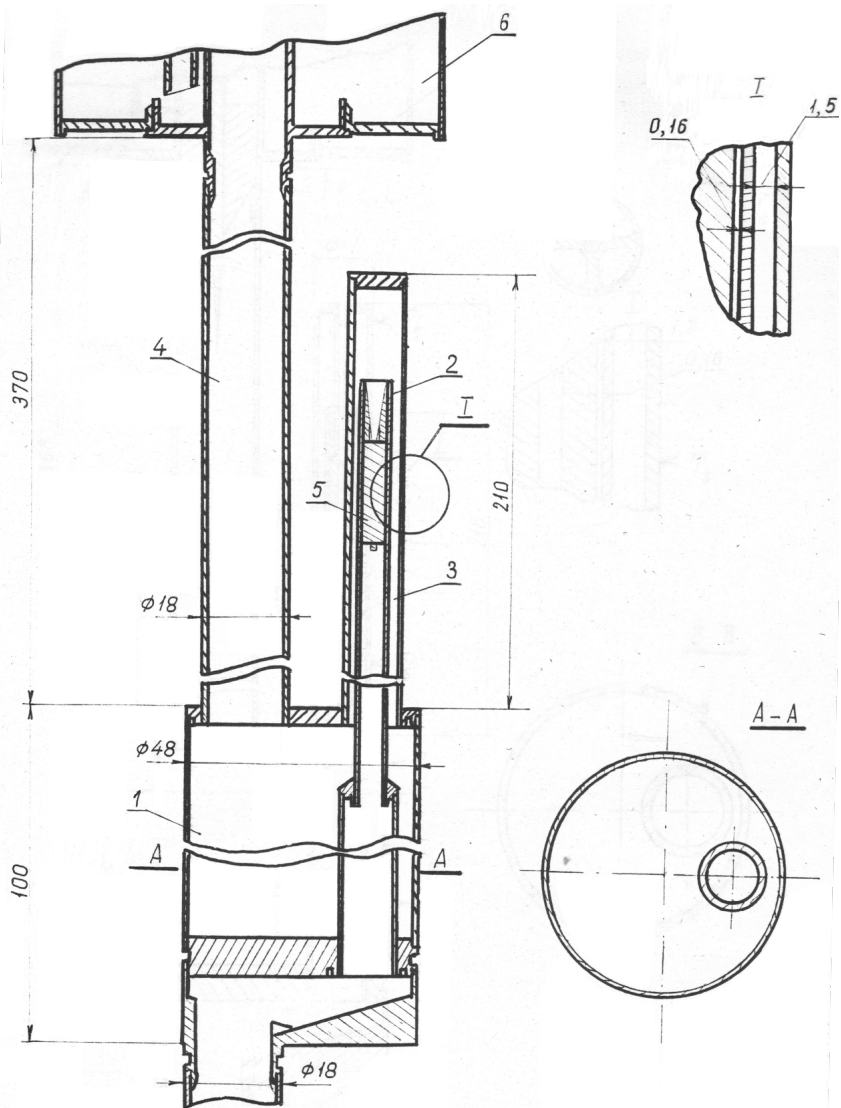

Figure 2. Measuring cell № 1

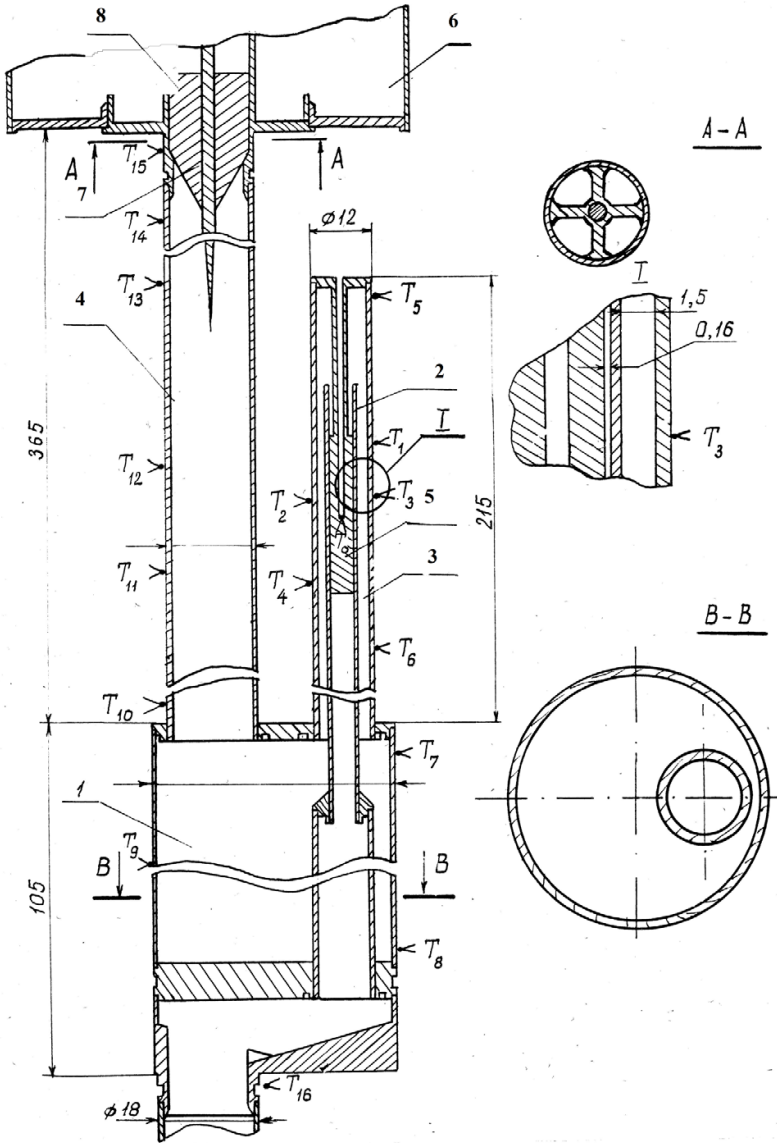

Figure 3. Measuring cell № 2

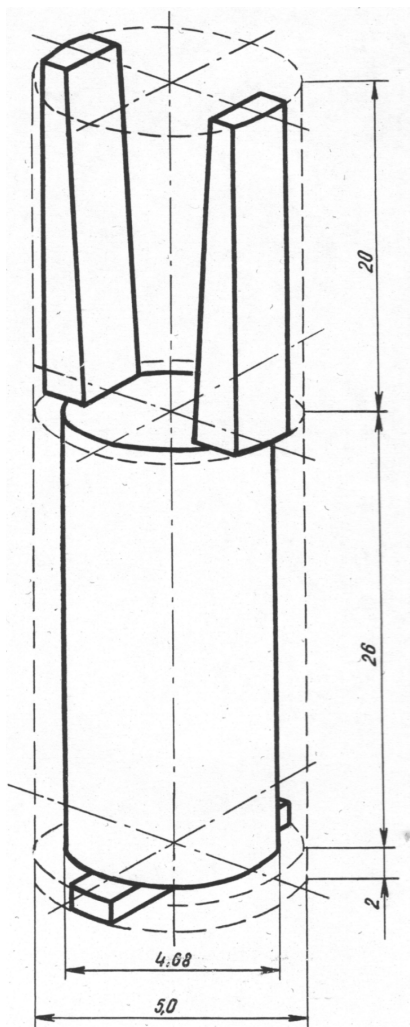

Figure 4. Cylindrical insert of the measuring cell № I

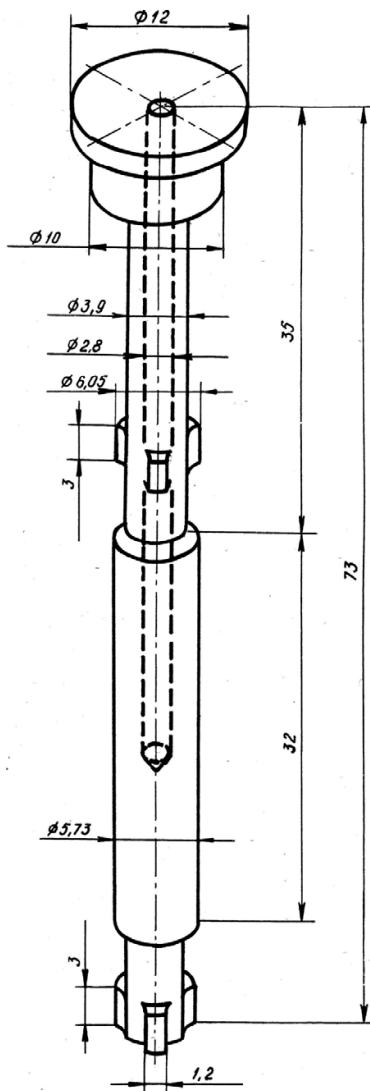

Figure 5. Cylindrical insert of the measuring cell № 2

The refrigerator of the measuring cell has two sections: low-temperature (water-cooled), designed to cool the vacuum seal cell-upper flange of the vacuum chamber and high-temperature ($T \sim 400$ K), cooled with silicone oil PFMS-4, designed to cool the drip devise.

The drip device (elements 7, 8, Figure 3) is used for condensation and return of liquid alkali metal in small portions (in the form of drops) to the steam generator 1. It is a needle-shaped tungsten rod 7, fixed by molybdenum heat sink 8 in the refrigerator area. The cell temperature was measured at control points T1 – T16 by tungsten – rhenium thermocouples BP5 / 20-I.

Liquid cranes are intended commutation of mains with alkali metal. They are (Figure 6) two coaxial tubes 1, 2 with an electric heater 3. In the main 1 is an alkali metal. The outer tube 2 can be cooled by water or heated by an electric heater 3.

In the cold state in the inner tube 1 a plug of crystalline alkali metal is formed – the valve is closed, when heating the section of the main above the melting point the plug is eliminated – the valve is open.

The real geometric factor of the viscometer with an annular channel differs from the calculated one. This is due to a number of reasons: tolerances to the size of the elements, the presence of fasteners and centering elements, the displacement of the elements of the viscometer due to thermal deformation and dimensional changes when heated. Therefore, to

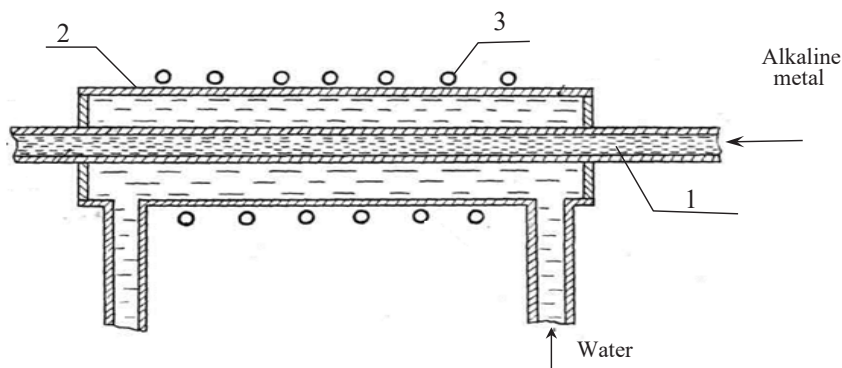

Figure 6. Liquid tap

determine the real value of the geometric factor of the measuring element, it is necessary to calibrate the viscosity of well-studied gases. In addition, the local loss factor remains unknown, which depends on the Reynolds number, geometric dimensions and shape of the annular channel. Theoretically, it is almost impossible to calculate the value. In most cases, it is determined by the results of calibration experiments [52; 53].

To determine the characteristics of the measuring element of the viscometer, stationary and non-stationary calibrations of measuring cells were performed.

Stationary calibration allows to determine the real value of the geometric factor f of the viscometer of the measuring cell, as well as to obtain the dependence $f(Re)$, which takes into account the loss of kinetic energy at the entrance to the measuring channel [6].

Calibration was performed at atmospheric pressure by the method of stationary purge of the measuring element with standard gases (dry air, argon).

The viscosity η_{st} of standard gases is taken from [54]. The Reynolds number was calculated by a known ratio:

$$R_e = \frac{2\rho v\sigma}{\eta},$$

where σ – the gap value of the channel, v – the average gas flow rate in the channel.

Before calibration, each measuring cell was annealed in vacuum at a pressure of $P = 1 \cdot 10^{-5}$ millimeters of mercury column and temperature $T = 1800 \dots 1900$ K for 2-3 hours. Stationary calibration was performed before and after experiments with alkali metal vapors. For calibration cell № 1 calibration 4 experiments were performed, and for cell № 2-5. Calibration experiments were performed in a wide range of Reynolds numbers ($Re = 10 \dots 220$), at a close value of Re were taken 3-7 experimental points, and their total number in the series ranged from 30 to 150. The obtained experimental values of the geometric factor f were approximated by a linear dependence $f = f_0 + A \cdot Re$.

The calibration results are shown in table 2, where: N is the number of experimental values, $\frac{\Delta f}{f}$ – the relative value of the relative error, %.

Based on the results of stationary calibration, the following conclusions can be drawn:

1. Geometric factors of measuring cells did not change during experiments with alkali metal vapors.

2. The loss of kinetic energy at the entrance to the measuring channel clearly depends on the Reynolds number. The value of the geometric factor, taking into account local losses in the range of Reynolds numbers $Re = 0 \dots 200$ decreases for cell № 1 by 6 %, and for cell № 2 by 2%.

The geometric factor of the measuring element of the viscometer with an annular channel also depends on the temperature. Its relative change (hereinafter the correction for thermal expansion is equal to:

$$\varepsilon_T = \frac{f_T}{f},$$

where f and f_T – the values of the geometric factor at the temperature of T_0 and T .

Table 2

The results of stationary calibration of the measuring cells

$$f \cdot 10^{12} = f_0 + A \cdot Re, m^3$$

Cell №	f_0	$A \cdot 10^4$	N	$\frac{\Delta f}{f}$ %	Re	Gas	Calibration time
1	1,206	2,85	146	0,56	10...220	Air	Before experiments with cesium
1	1,221	3,17	47	0,74	16...178	Argon	
1	1,209	2,90	26	0,80	20...166	Argon	After experiments with cesium
1	1,218	3,33	94	0,64	18...200	Air	
1	1,214	3,00	313	0,46	10...220		Generalized meaning
2	0,660	0,649	87	0,72	22...205	Air	Before experiments with cesium
2	0,666	0,679	58	0,78	26...110	Argon	
2	0,668	0,685	104	0,66	28...210	Air	After experiments with cesium, before experiments with rubidium vapor
2	0,660	0,633	43	0,88	20...85	Argon	
2	0,662	0,654	76	0,68	18...160	Air	After experiments with rubidium vapor
2	0,663	0,653	368	0,56	18...210		Generalized meaning

To determine the correction, non-stationary calibration of the measuring cells in the operating temperature range was performed (for the cell № 1 $T = 800 \dots 1500$ K, for the cell № 2 $T = 800 \dots 1850$ K). The correction was determined depending on the time of change of the pressure difference of the inert gas that passed through the measuring cell of the viscometer.

Non-stationary calibration of the measuring cells was performed on argon and neon of high purity. Since in the cell № 2 the cylindrical insert of the viscometer (Figure 3) can be shifted in the vertical direction when

Table 3

Results of non-stationary calibrations of the measuring cells

Cell, №	Interval temperatures, K	α	$b \cdot 10^5$	N	$\frac{\sigma \varepsilon_i}{\varepsilon_i}, \%$	Gas	Calibration time
1	800...1500	1,034	7,75	59	0,80	argon	Before conducting experiments with cesium vapor
1	800...1430	1,042	7,53	21	0,98	neon	
1	800...1360	1,046	7,69	33	0,86	argon	During experiments with cesium vapor
1	820...1400	1,038	7,57	64	1,10	argon	After conducting experiments with cesium vapor
1	800...1500	1,040	7,62	177	0,77		Generalized meaning
2	790...1850	1,170	2,81	81	0,76	argon	Before conducting experiments with cesium vapor
2	830...1840	1,163	2,98	33	0,92	neon	
2	850...1800	1,159	3,06	42	0,86	argon	During experiments with cesium vapor
2	810...1850	1,172	2,73	48	0,73	argon	After experiments with cesium vapor, before experiments with rubidium vapor
2	960...1810	1,175	2,80	37	1,02	argon	During experiments with rubidium vapor
2	920...1500	1,165	2,90	40	0,86	argon	During experiments with rubidium vapor
2	790...1850	1,168	2,85	281	0,63		Generalized meaning

the cell is heated, the amount of correction ε_i can change with increasing evaporator temperature. Therefore, for the cell № 2 additional calibration experiments were performed at different temperatures of the steam generator.

As can be seen from Figure 1, non-stationary calibration can be performed on the main experimental installation. This allows you to control the value of the geometric factor f during experiments with vapors of alkali metals, without disassembling the installation. To do this, the alkali metal during the experiment was completely distilled from the steam generator into the flow meter, where it was frozen, and then there was conducted, according to the previously described method, a series of reference and control experiments.

In the temperature range $T = 800 \dots 1850$ K (for the cell № 1 $T = 800 \dots 1500$ K) the dependence is described within the error of calibration experiments by linear dependence:

$$\varepsilon_i = a + bT.$$

The calibration results are shown in table 3, where N – the number of experimental points; $\frac{\sigma\varepsilon_i}{\varepsilon_i}$ – standard, %.

The relative changes $\frac{\varepsilon_i}{\varepsilon_i}$ in the corrections for the cells in the operating temperature range are:

- for the cell № 1 $(\varepsilon_{1500} - \varepsilon_{800}) / \varepsilon_{800} = 4,8\%$;
- for the cell № 2 $(\varepsilon_{1850} - \varepsilon_{800}) / \varepsilon_{800} = 2,5\%$.

Corrections for thermal expansion $\varepsilon_i(T)$ for both measuring cells changed monotonically, no hysteresis dependences $\varepsilon_i(T)$ were observed.

3. Experimental part

Alkali metal in the glass ampoules was placed in the refuelling device 19 (Figure 1). The working volume of the installation was pumped to a pressure of $P \sim 10^{-5} - 10^{-6}$ millimetres of mercury column). The gas system, flow meter, drain and ballast vessel were heated to a temperature of $400 \dots 500$ K. The working volume of the installation was «washed» several times with argon, and then filled with high purity argon ($P = 100$ kPa). The pressure in the receivers 22 and 23, the cell, the filling device and the drain vessel was equalized. The temperature of the drain vessel and the filling device was maintained at $60 - 80$ ° C above the melting point of the alkali metal.

With the closed liquid taps 15 and 17 in the filling device the glass ampoule with alkali metal is crushed, and liquid alkali metal flows into the drain vessel. The level of metal in the drain vessel is controlled by a contact needle. The flowmeter is heated, the liquid tap 17 is opened. Excess pressure of argon is created – between the drain vessel and the flowmeter, then the initial level of alkali metal in the flowmeter is exposed. The liquid valve 17 is closed. The drain and ballast vessels, the main pipeline 29, the steam generator, the pressure pipe, the refrigerator of the measuring cell are heated. The liquid tap 16 opens. Excess argon pressure is created between the drain and ballast vessels. With excess pressure, the alkali metal is first distilled into the ballast vessel 18, and from there flows into the steam generator 1 of the measuring cell. Liquid valves 15 and 16 are closed, the pressure in the gas system is equalized.

The alkali metal vapor elasticity curve $P=f(T)$ [51] determines the temperature T and the vapor saturation pressure P_S of the investigated alkali metal, which corresponds to the planned parameters of the experiment. In the gas system of the installation argon P_{Ar} pressure is created, which is slightly higher P_S . The flow meter, the condensate collection path ($T = 400 \dots 450$ K) and the refrigerator of the measuring cell ($T = 300 \dots 400$ K) are heated.

The boiler (steam generator) and the viscometer of the measuring cell are adjusted at the appropriate temperature T_K , T_B . When $P_{Ar} > P_S$ liquid alkali metal is «crushed» by argon. The pressure in the gas system is slowly released. When $P_{Ar} = P_S$ the process of boiling alkali metal in the steam generator of the measuring cell begins. Hot alkali metal vapor fills the pressure pipe. The boiling moment is recorded by the readings of thermocouples $T_{10} \dots T_{15}$ installed on the height of the pressure pipe of the measuring cell (Figure 7).

The alkali metal vapor column displaces argon from the hot zone of the pressure pipe into the refrigerator zone. There is no alkali metal vapor in the cold zone of the pressure pipe and argon in the hot zone. Thus, the alkali metal vapor is «locked» by argon, i. e. we have the ability to regulate the alkali metal vapor pressure through the intermediate inert gas. This method of setting the pressure has been repeatedly used in thermal and spectrophysical experiments with alkali metal vapors [6; 24; 27; 34] and has shown high reliability.

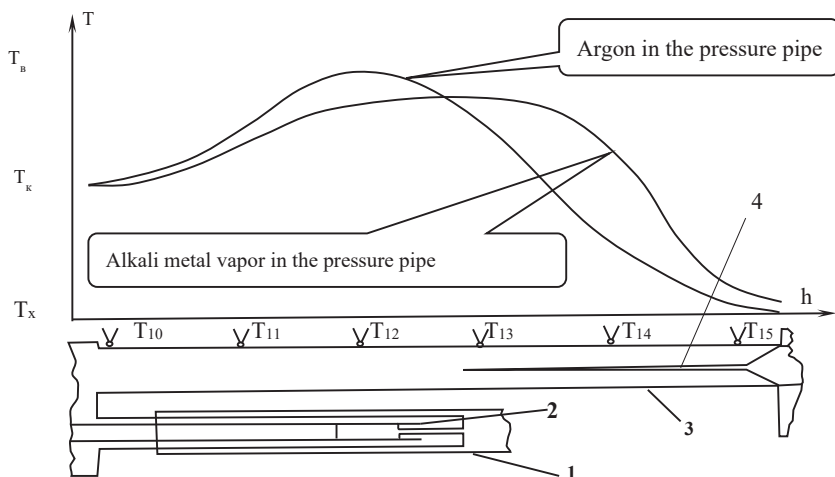

**Figure 7. Temperature distribution by the height of the pressure pipe:
 1 – heater, 2 – viscometer, 3 – pressure pipe, 4 – drip device,
 T10-T15 thermocouple BP5 / 20**

Alkali metal vapor condenses on the drip device. It then flows down the needle of the drip device into the upper part of the hot zone of the pressure pipe and in small portions (in the form of small drops) returns to the steam generator, partially evaporating in the counterflow of steam. The counterflow of steam also carries argon into the cold zone, which is released from the liquid alkali metal on the needle of the drip device. The alkali metal condenses on the refrigerator of the drip device and flows down the needle of the drip device down in small drops. It returns to the evaporator at a temperature close to the boiling point, which provides high stability of steam generation. As can be seen from Figure 7, drainage of alkali metal on the walls of the pressure pipe is impossible, because the wall temperature is much higher than its boiling point.

After stabilization of temperature modes of the installation between the receivers 22 and 23 (Figure 1) the pressure difference on the measuring element is set. Under the action of the pressure drop, alkali metal vapor passes through the end channel and condenses in the cold part of the condensate collection line, then flows into the flow meter. In the flowmeter,

the metal level is controlled by a contact needle. The contact needle is moved by the device of small displacements 14, the displacement of the needle is determined by the catheter 19 (Figure 1). Consumption of alkali metal is determined by the rate of filling the flow meter.

At stable modes of the operation of installation the speed of filling of the flowmeter $B = \Delta h / \tau$ (Δh -height of rise of level of condensate of the flowmeter for a period of time $\Delta \tau$) has to be constant, and dependence $h=f(\tau)$ – linear:

$$h = h_0 + B \cdot \tau.$$

To increase the accuracy of measuring the flow of alkali metal and control the process of condensate flow into the flow meter during the experiment, the coefficients h_0, B and their random errors were calculated $\delta h_0 / h_0, \delta B / B$ [26; 63; 69]. The experiments were completed when the required accuracy of the coefficient was reached B (in most cases $\delta B / B < 1\%$. If this level was not reached, the measurement cycle was terminated due to the limited service life of the installation. Typically, condensate level measurements in the flowmeter were performed 5-15 times for each measurement cycle. After full consumption of the alkali metal of the steam generator, the liquid alkali metal was distilled from the flow meter into the drain vessel and then into the steam generator, and the measurement cycle was repeated at new parameter values.

Two series of the experiments with cesium vapor and one series of experiments with rubidium vapor were performed. The experiments were performed on isotherms, with the deviation of the points on the isotherm was 10 ... 15 K.

The first series of the experiments with Cs pairs was performed on the measuring cell №1 without a drip device. 46 experimental values of viscosity in the temperature range 900 ... 1250 K at pressures 12 ... 125 kPa were obtained [65; 69; 74]. At temperatures above 1300 K there was instability in the operation of the steam generator installation.

The second series of the experiments was performed with a measuring cell № 2, which is equipped with a drip device. The drip device provided high stability of the steam generator of the measuring cell in a wide range of temperatures and pressures. 121 experimental values of cesium vapor viscosity were obtained, the temperature range of 960 ... 1770 K at pressures

of 19 ... 135 kPa was investigated [59; 69; 70; 71; 72]. The installation worked stably.

Experiments with rubidium vapor were performed on the cell № 2, 61 experimental values of viscosity in the temperature range of 990 ... 1750 K at pressures of 39 ... 135 kPa were obtained [66; 72].

The temperature of the measuring element of the viscometer during the experiments was maintained with high accuracy. During the experiments, the temperature variation in the height of the working element of the viscometer was $\pm 2 \dots 5$ K (thermocouples T_0, T_1, T_2, T_3, T_4 , Figure 7), the temperature change during the experiments did not exceed $\pm 2 \dots 3$ K. For the cell № 2, the difference between readings between thermocouples T_2, T_3 and central T_0 , which is located inside the cylindrical insert of the viscometer, did not exceed $2 \dots 3$ K, i. e. was outside the accuracy of temperature measurement by thermocouples.

The temperature of the steam generator during the experiments was also quite stable. There was almost no change in the readings of thermocouples $T_7 - T_9$ over time during the experiment. The temperature difference in the height of the steam generator did not exceed 10 K. The high stability of the evaporator cell № 2 is primarily due to the high efficiency of the drip device.

The experiments used alkali metals of the following composition (according to the passports of the manufacturer):

cesium:

$Cs \geq 99,99 \%$; $K < 0,002 \%$; $Na < 0,0005 \%$; $Ca < 0,005 \%$; $Rb < 0,001 \%$;

rubidium:

$Rb \geq 99,97 \%$; $K < 0,003 \%$; $Na < 0,0003 \%$; $Cs < 0,03 \%$.

During the experiment, the state of the alkali metal in the installation was monitored by comparing the experimental viscosity values determined at close parameters at the beginning and the end of each series of experiments.

Calculation formula of the method:

$$\eta = \frac{\pi\mu}{24RTQ_m} (2P_2 + \Delta P)\Delta P^* f_{\varepsilon_T}\varepsilon_\lambda, \quad (1)$$

$$\Delta P^* = \Delta P - \left(0.77\rho V^2 - \frac{\Delta P^2}{P_2} \right), \quad (2)$$

Where η – the dynamic viscosity of the alkali metal vapor, T – the vapor temperature, ΔP – the pressure drop across the measuring channel, Q_m – the mass flow rate, P_2 – the vapor pressure at the outlet of the measuring channel, μ – the molar mass, ρ – the vapor density, V – the average vapor flow rate measuring channel, f – geometric factor of the cell, ε_λ – correction for the molecular slip, ε_T – correction for the thermal expansion.

Given the composition of the pair, its molar mass is equal to:

$$\mu = \mu_0 (1 + x_2), \quad (3)$$

where x_2 – the molar fraction of molecules in the pair (1,63 – 1,65);

μ_0 – molar mass of the atom.

Mass costs of steam Q_m are:

$$Q_m = \rho_p \pi R_T^2 \frac{\Delta h}{\tau} = \rho_p \pi R_T^2 B, \quad (4)$$

where ρ_p – the density of the liquid phase of the alkali metal at the temperature T ;

R_T – radius of the flowmeter at temperature T_p .

$$R_T = R [1 + \alpha (T_p - T_0)]$$

T_0 – flow meter calibration temperature;

R – temperature flow meter radius T_0 ;

α – coefficient of linear expansion.

The condensate density was determined from the data [63]:

$$\rho_{Cs} \cdot 10^{-3} = 1,9058924 + 0,29801989\tau - 0,028529531\tau^2 + 4,6810162\tau^3 + 4,0361819\tau^4 + 1,736613\tau^5 - 0,29684317\tau^6, \text{ kg/m}^3 \quad (5)$$

$$\rho_{Rb} \cdot 10^{-3} = 1,3511203 + 1,5219888\tau - 5,4165931\tau^2 + 7,415271\tau^3 - 5,3606866\tau^4 - 1,9604833\tau^5 - 0,28895999\tau^6, \text{ kg/m}^3 \quad (6)$$

where $\tau = T_p / 1000$

The alkali ρ metal vapor density was determined by the equation:

$$\rho_{\Pi} = \mu_0 (1 + x_2) \frac{\bar{P}}{RT_T}, \quad (7)$$

where \bar{P} – the average pressure of the experiment $\bar{P} = P_2 + \frac{\Delta P}{2}$;

T_T – gas vapor temperature in the viscometer channel.

The effective values of the geometric factors f of the cells and the correction for the thermal expansion of the measuring elements ε_T were determined by the results of the calibrations:

for the cell № 1

$$f = (1,214 + 3,00 \cdot 10^{-4} Re) \cdot 10^{-12}, m^3 \quad (8)$$

$$\varepsilon_T = 1,040 + 7,62 \cdot 10^{-5} T, \quad (9)$$

for the cell № 2

$$f = (0,663 + 6,53 \cdot 10^{-5} Re) \cdot 10^{-12}, m^3 \quad (10)$$

$$\varepsilon_T = 1,168 + 2,85 \cdot 10^{-5} T. \quad (11)$$

Reynolds numbers Re were determined by the equation (12),

$$Re = \frac{2\rho v \sigma}{\eta}, \quad (12)$$

where σ – the magnitude of the gap of the channe;

v – ge average gas flow rate in the channel.

Correction ε_λ for the molecular slip by equation:

$$\varepsilon_\lambda = 1 + \frac{6\lambda}{\sigma}, \quad (13)$$

where λ – the average free path of the molecules is three temperatures T .

The contribution of the correction for the viscosity in rubidium vapors is 0,2-4,1 %, and for cesium – 0,2-3,1%.

The average free path length of atoms λ included in the equation (13) is equal to:

$$\lambda = \frac{\eta_1}{0,49\rho\bar{c}}, \quad (14)$$

where η_1 – the viscosity of a monoatomic pair, which in the first approximation was calculated by [2].

The average thermal velocity \bar{A} of atoms is:

$$\bar{c} = \sqrt{\frac{8RT}{\pi\mu}} \quad (15)$$

The average flow rate of steam in the channel was determined by the ratio:

$$\bar{v} = \frac{Q_m}{\rho S}, \quad (16)$$

where S – the cross-sectional area of the channel.

The constants used in the calculations:

1. Energy of the dissociation of molecules [5]:

$$D_{OCS}^0 = 44380 \pm 1000 \text{ Дж/моль}, D_{ORb}^0 = 48570 \pm 1000 \text{ J/mol.}$$

2. Molar masses of the monoatomic components [53]:

$$\mu_{Cs} = 132,9054 \text{ kg/kmol}, \mu_b = 85,4673 \text{ kg/kmol.}$$

3. The oil density of U-manometers was determined experimentally by comparing the readings of oil, water and mercury manometers:

$$\rho_m = 881 \pm 3 \text{ kg/m}^3 \text{ – for the cell № 1, } i\rho_m = 993 \pm 3 \text{ kg/m}^3 \text{ – for the cell № 2.}$$

An experimental study of the viscosity of cesium vapor (T = 900-1770 K, P = 12-130 kPa, two series of experiments, 205 experimental values of viscosity) and rubidium (T = 960-1750 K, P = 35-135 kPa, obtained – 61 experimental value of viscosity) was carried out and the confidence interval of the error of the experimental values of viscosity at the confidence level of P = 0,95 is in the range of 2,5 – 3,6% and averages 3%.

Table 4

Experimental values of cesium viscosity in the gas phase

№	T, K	P, kPa	$\eta \cdot 10^7, Pa \cdot S$	X ₂ , %	$\Delta\varepsilon, \%$	№	T, K	P, kPa	$\eta \cdot 10^7, Pa \cdot S$	X ₂ , %	$\Delta\varepsilon, \%$
1	2	3	4	5	6	7	8	9	10	11	12
I series of experiments						I series of experiments					
1	903	12,0	265,5	1,49	3,9	44	1227	42,9	330,0	0,98	3,9
2	906	13,4	264,4	1,62	3,1	45	1233	25,6	342,7	0,57	3,1
3	911	15,8	263,5	1,84	3,1	46	1254	48,7	348,1	1,00	3,0
4	917	26,5	264,0	2,90	3,7	II series of experiments					
5	916	40,4	253,6	4,31	2,7	1	964	60,7	269,6	4,70	3,4
6	914	40,2	251,2	4,34	3,5	2	972	80,1	263,8	5,78	2,8
7	916	48,6	252,2	5,10	2,8	3	973	27,3	273,4	2,11	2,8
8	921	56,2	246,0	5,64	3,4	4	974	30,5	277,7	2,34	2,7
9	924	52,1	250,2	5,17	4,2	5	975	44,2	271,9	3,30	2,7
10	920	51,7	251,2	5,27	3,2	6	975	36,2	273,6	2,73	2,8
11	972	86,4	264,8	6,18	2,8	7	975	20,8	282,6	1,61	2,9
12	973	43,7	273,0	3,30	2,9	8	977	71,0	265,2	5,05	2,7
13	1038	46,7	288,2	2,47	2,7	9	977	88,3	263,2	6,13	2,7
14	1057	73,8	288,9	3,46	4,3	10	978	58,0	268,5	4,17	2,8
15	1056	91,5	286,3	4,24	2,8	11	978	33,7	276,3	2,51	2,8

Viktor Dzis, Olena Dyachynska

(Continuation of the Table 4)

1	2	3	4	5	6	7	8	9	10	11	12
16	1040	20,1	310,5	1,08	4,3	12	978	93,9	264,6	6,44	2,7
17	1040	67,1	286,7	3,45	2,8	13	980	74,4	269,2	5,18	2,7
18	1031	52,2	288,7	2,85	3,5	14	1040	70,8	284,6	3,62	2,8
19	1054	88,0	287,0	4,13	3,0	15	1046	38,0	293,7	1,95	2,8
20	1052	108,7	278,8	5,06	3,5	16	1047	106,9	283,0	5,11	3,1
21	1048	39,0	295,4	1,98	3,0	17	1048	75,8	291,0	3,71	2,6
22	1055	76,5	282,5	3,61	4,5	18	1048	43,7	296,2	2,20	2,8
23	1052	122,6	275,1	5,64	2,8	19	1049	54,5	290,0	2,71	3,1
24	1059	101,0	280,6	4,58	2,9	20	1049	133,7	278,1	6,18	2,7
25	1057	76,6	282,7	3,58	2,7	21	1050	84,5	280,2	4,06	3,5
26	1045	47,7	284,8	2,43	3,2	22	1052	122,1	272,0	5,62	2,9
27	1128	119,7	304,2	3,92	3,0	23	1068	80,3	292,2	3,55	2,8
28	1129	87,3	299,0	2,91	3,4	24	1128	58,6	305,7	2,00	2,7
29	1139	66,8	307,5	2,16	3,0	25	1129	112,7	305,9	3,69	2,7
30	1121	50,8	306,0	1,80	3,1	26	1129	45,3	316,6	1,55	3,5
31	1134	18,4	318,0	0,63	2,9	27	1130	86,4	309,1	2,89	2,9
32	1138	29,2	307,3	0,97	3,2	28	1134	75,9	312,5	2,49	2,7
33	1143	74,8	313,4	2,36	3,3	29	1134	41,1	312,4	1,38	3,2
34	1152	52,6	308,5	1,62	3,2	30	1136	103,2	312,4	3,30	2,7
35	1133	132,9	395,6	4,23	2,7	31	1138	58,0	318,0	1,89	3,2
36	1143	112,8	300,2	3,48	3,0	32	1144	72,6	310,8	2,29	2,7
37	1139	69,8	303,6	2,25	2,7	33	1225	98,8	333,1	2,21	2,7
38	1139	31,4	316,1	1,04	2,9	34	1225	76,4	341,4	1,73	2,8
39	1245	109,8	330,3	2,27	3,3	35	1226	106,7	325,3	2,37	3,2
40	1235	132,2	323,7	2,81	2,9	36	1228	66,8	349,0	1,50	2,8
41	1234	116,9	325,3	2,51	2,9	37	1229	131,6	332,5	2,86	2,7
42	1239	91,2	334,2	1,94	2,8	38	1231	51,3	348,9	1,15	2,7
43	1240	107,1	319,6	2,26	3,0	39	1231	124,8	336,6	2,70	2,8
40	1231	29,4	346,0	0,66	3,4	81	1499	113,8	410,1	1,04	2,7
41	1233	58,0	343,8	1,28	2,8	82	1500	35,9	432,1	0,33	2,8
42	1234	39,5	348,7	0,88	2,8	83	1501	75,0	418,7	0,69	3,0
43	1236	115,4	347,6	2,46	3,0	84	1503	94,0	410,0	0,86	3,1
44	1236	85,7	340,5	1,85	2,8	85	1504	30,5	430,7	0,28	2,8
45	1237	43,8	343,3	0,96	3,8	86	1504	134,1	414,3	1,21	2,8
46	1239	38,0	349,0	0,83	2,7	87	1505	57,9	420,1	0,53	3,2

Chapter «Technical sciences»

(End of Table 4)

1	2	3	4	5	6	7	8	9	10	11	12
47	1325	39,0	375,5	0,62	2,9	88	1506	98,8	426,3	0,89	2,7
48	1326	79,7	372,7	1,25	3,0	89	1508	43,8	426,4	0,40	2,8
49	1328	80,2	367,7	1,25	2,6	90	1508	131,3	423,3	1,17	2,9
50	1328	100,6	367,0	1,56	3,1	91	1508	121,3	410,2	1,09	3,0
51	1329	113,8	366,6	1,75	3,4	92	1510	83,4	427,2	0,75	2,6
52	1329	133,8	364,1	2,04	2,8	93	1513	47,8	430,1	0,43	2,6
53	1329	120,7	366,8	1,85	3,4	94	1596	58,8	459,4	0,42	2,8
54	1330	88,1	367,5	1,36	2,7	95	1597	117,3	450,6	0,83	2,9
55	1330	58,5	372,9	0,91	4,2	96	1598	114,3	446,0	0,81	2,6
56	1332	58,0	368,3	0,90	2,8	97	1598	19,4	435,1	0,14	2,7
57	1332	43,5	371,4	0,68	2,9	98	1600	90,9	448,1	0,64	2,8
58	1334	72,6	372,0	0,11	2,9	99	1601	106,4	457,1	0,75	2,7
59	1334	48,7	368,7	0,75	3,3	100	1603	99,3	452,1	0,70	3,4
60	1335	31,2	376,3	0,48	4,2	101	1605	83,8	451,9	0,59	2,6
61	1335	127,0	373,3	1,90	2,7	102	1607	72,0	442,9	0,50	2,9
62	1336	44,2	377,1	0,68	3,2	103	1607	38,4	442,8	0,27	2,8
63	1337	99,1	374,2	1,49	2,7	104	1608	30,4	464,0	0,21	3,0
64	1338	69,2	370,1	1,05	2,8	105	1609	20,3	460,8	0,14	2,9
65	1343	91,9	372,2	1,36	2,7	106	1609	36,0	429,3	0,25	2,7
66	1350	121,2	367,2	1,73	3,4	107	1610	45,8	459,3	0,32	2,6
67	1427	57,3	395,8	0,65	3,1	108	1610	26,3	465,0	0,18	2,9
68	1429	98,8	391,6	1,11	3,2	109	1691	101,6	452,8	0,58	2,7
69	1429	130,4	392,8	1,46	2,7	110	1693	119,1	454,7	0,67	2,8
70	1430	68,0	404,0	0,77	2,9	111	1696	112,4	452,6	0,63	2,7
71	1430	120,5	395,8	1,34	2,9	112	1729	84,2	468,4	0,44	3,1
72	1430	28,8	404,6	0,33	2,7	113	1747	102,2	469,0	0,51	2,8
73	1431	73,2	387,0	0,82	2,9	114	1751	86,1	466,9	0,43	2,9
74	1433	113,8	397,5	1,26	2,8	115	1752	108,7	475,6	0,54	2,9
75	1434	20,0	413,9	0,28	2,9	116	1758	74,9	468,4	0,37	2,9
76	1435	89,3	402,8	0,99	3,0	117	1763	35,9	482,6	0,18	3,2
77	1437	117,4	405,6	1,28	3,1	118	1764	53,3	486,0	0,26	2,8
78	1446	95,8	405,3	1,03	2,6	119	1767	42,9	480,2	0,21	2,9
79	1498	100,9	424,5	0,93	3,3	120	1770	98,1	464,9	0,47	2,8
80	1498	71,3	416,8	0,66	2,8	121	1770	64,6	475,4	0,31	3,1

Table 5

Experimental values of rubidium viscosity in the gas phase

№	T, K	P, kPa	$\eta \cdot 10^7$, Pa · S	X ₂ , %	$\Delta\varepsilon$, %	№	T, K	P, kPa	$\eta \cdot 10^7$, Pa · S	X ₂ , %	$\Delta\varepsilon$, %
1	2	3	4	5	6	7	8	9	10	11	12
1	989	41,9	255,9	3,41	2,9	32	1312	111,2	335,4	1,87	2,7
2	995	114,2	235,9	8,10	3,0	33	1313	59,2	334,6	1,01	3,1
3	996	59,5	251,1	4,52	3,3	34	1322	135,9	323,7	2,19	2,9
4	998	105,6	232,1	7,45	2,7	35	1437	117,6	363,6	1,28	3,1
5	998	87,0	242,8	6,29	3,0	36	1438	108,9	372,5	1,19	3,1
6	1010	110,4	233,8	7,25	3,1	37	1440	75,5	355,7	0,82	3,0
7	1096	132,7	262,9	5,51	3,0	38	1443	90,2	361,2	0,97	3,0
8	1098	100,8	275,3	4,25	3,0	39	1444	118,1	358,7	1,26	4,2
9	1098	126,7	259,1	5,24	2,8	40	1444	39,6	364,7	0,43	3,2
10	1100	86,0	277,1	3,64	3,7	41	1445	135,9	354,2	1,44	3,1
11	1102	60,2	281,0	2,50	2,9	42	1447	65,3	369,2	0,70	3,0
12	1103	103,5	278,4	4,25	2,9	43	1447	52,8	366,0	0,57	3,7
13	1104	79,3	281,2	3,31	3,0	44	1449	56,2	364,7	0,60	3,2
14	1104	124,6	262,3	5,01	3,5	45	1450	39,6	372,0	0,42	3,0
15	1105	76,5	278,8	3,18	3,0	46	1452	46,8	361,1	0,49	3,9
16	1105	63,0	283,5	2,65	3,3	47	1563	106,3	409,0	0,80	4,0
17	1112	43,1	284,3	1,78	3,3	48	1563	104,6	400,4	0,79	3,1
18	1115	35,1	287,4	1,43	4,7	49	1578	121,5	400,7	0,87	3,6
19	1122	116,3	271,4	4,32	4,0	50	1580	90,4	404,3	0,65	3,2
20	1231	70,4	316,9	1,65	3,0	51	1582	126,3	396,8	0,90	3,1
21	1236	43,5	316,5	1,01	3,6	52	1583	102,5	401,3	0,73	3,1
22	1237	79,7	316,5	1,82	3,6	53	1584	80,2	414,0	0,57	3,5
23	1240	114,1	297,5	2,54	3,1	54	1584	134,8	401,6	0,95	3,1
24	1246	120,7	315,0	2,61	2,7	55	1591	125,7	400,2	0,87	3,0
25	1249	126,7	306,6	2,70	3,1	56	1734	105,3	451,9	0,51	3,1
26	1299	120,6	324,6	2,12	2,8	57	1736	80,3	450,4	0,39	3,9
27	1300	78,8	333,8	1,40	3,3	58	1739	134,0	442,4	0,64	4,2
28	1300	86,4	330,1	1,53	3,0	59	1740	94,9	453,5	0,45	2,9
29	1301	102,8	331,0	1,81	3,1	60	1746	123,8	445,5	0,58	3,0
30	1308	126,3	321,7	2,15	3,9	61	1751	125,4	449,1	0,58	3,3
31	1311	112,7	321,7	1,90	3,1						

where: T – alkali metal vapor temperature, K;

$\bar{P} = P_2 + \Delta P$ – average pressure, kPa;

η – experimental value of viscosity, $Pa \cdot s$;

ΔP – pressure drop at the measuring section, kPa;

x_2 – molar fraction of diatomic molecules in the alkali metal vapor, %;

$\Delta \varepsilon$ – the confidence limit of the error of the experimental value of the viscosity at a confidence level of $P = 0,95$.

The molar fraction of diatomic molecules was calculated according to [2].

$$x_2 = 1 - \frac{2}{1 + \sqrt{1 + \frac{4P}{1,01325K_p}}}, \quad (17)$$

where P – the pressure of vapour; K_p – equilibrium constant.

$$K_p = \exp \left\{ \frac{2\Phi_1^* \cdot \Phi_2^*}{R} - \frac{D_0^0}{RT} \right\} \quad (18)$$

where T – temperature vapour;

D_0^0 – dissociation energy of the molecules;

R – universal gas table;

Φ_1^* and Φ_2^* – respectively isobaric – isothermal potential of the atomic and molecular components [44]:

$$\Phi_i^* = f_0 + f \cdot \ln \chi + f_{-2} \cdot \chi^2 + f_{-1} \cdot \chi^{-1} + f_1 \cdot \chi + f_2 \cdot \chi^2 + f_3 \cdot \chi^3$$

where $\chi = T / 1000$, and the values of the coefficients f_i are given in table 6.

Table 6

Coefficients of equation 1.65 [44]

f_i	Cesium		Rubidium	
	$2\Phi_1^* - \Phi_2^*$		$2\Phi_1^* - \Phi_2^*$	
	$298,6 < T \leq 1500 \text{ K}$	$1500 < T \leq 6000 \text{ K}$	$298,6 < T \leq 1500 \text{ K}$	$1500 < T \leq 6000 \text{ K}$
f_0	121,649	444,587	112,349	370,373
f	17,1427	224,653	13,8048	190,8541
f_{-2}	-1,2241·10-3	-0,6190364	-1,0199·10-3	-0,6288884
f_{-1}	0,26749	27,35144	0,19684	25,54826
f_1	-271,4918	-790,859	-194,6768	-589,339
f_2	1062,86	644,888	750,05	419,334
f_3	-1694,904	-230,756	-1135,468	-129,528

For cesium and rubidium in the temperature range $T = 900 \dots 1800$ K and pressures $P = 10 \dots 150$ kPa at $D_{0cs}^\circ = 44380$ J/mol, $D_{0rb}^\circ = 48570$ J/mol [45] the molar fraction of the molecules is $x_2 = 0.1 \dots 10$ %.

4. Calculation of the collision cross sections

The viscosity of the alkali metal vapor can be expressed through two parameters [2]: the effective cross-sections of the «atom-atom» $\sigma_{11}^2 \Omega_{11}^{(2,2)*}$ collisions and the relative cross-section of the «atom-molecule» β_{12}^2 collisions. The effective cross-sections of «atom-atom» $\sigma_{11}^2 \Omega_{11}^{(2,2)*}(T)$ collisions characterize the dependence of the viscosity of a monoatomic pair on temperature, and relative β_{12}^2 – the dependence of viscosity on the concentration of the diatomic molecules, which is a function of pressure.

The viscosity of a two-component mixture is determined from the ratio [2; 3]:

$$\frac{1}{\eta} = \frac{X_\eta + Y_\eta}{1 + Z_\eta}, \quad (19)$$

$$X_Z = \frac{1}{\eta_1} X_1^2 + \frac{2x_1}{\eta_{12}} + \frac{1}{\eta_{22}} X_2^2, \quad (20)$$

$$Y_\eta = \frac{3}{5} A_{12}^* \left\{ \frac{x_1^2 M_1}{\eta_1 M_2} + \frac{2x_1 x_2}{\eta_{12}} \cdot \frac{(M_1 + M_2)^2}{4M_1 M_2} \frac{\eta_{12}^2}{\eta_1 \eta_{22}} + \frac{x_2^2 M_2}{\eta_2 M_1} \right\}, \quad (21)$$

$$Z_\eta = \frac{3}{5} A_{12}^* \left\{ x_1 \frac{M_1}{M_2} + 2x_1 x_2 \cdot \left[\frac{(M_1 + M_2)^2}{4M_1 M_2} \left(\frac{\eta_{12}}{\eta_1} + \frac{\eta_{12}}{\eta_{22}} \right) - 1 \right] + x_2^2 \frac{M_1}{M_2} \right\}, \quad (22)$$

$$\eta_{ij} \cdot 10^7 = 26,693 \sqrt{\frac{2M_i M_j T / (M_i + M_j)}{\sigma_{ij}^2 \Omega_{ij}^{(2,2)*}}}, \quad (i, j = 1, 2), \text{ Pa} \cdot \text{s}, \quad (23)$$

$$\eta_{11} = \eta_1, \eta_{22} = \eta_2, \sigma_{11}^2 = \sigma_1^2, \sigma_{22}^2 = \sigma_2^2, \quad (24)$$

where M_1, M_2 – the mass of the atom and the molecule of the alkali metal, respectively;

x_1, x_2 – molar particles of the atoms and molecules;

η_1 – viscosity of the monoatomic gas;

η_2 – viscosity of the diatomic gas;

η_{12} – the viscosity of a hypothetical gas consisting of molecules by mass $2M_1 M_2 T / (M_1 + M_2)$, interacting on the potential curve of the atom-molecule;

$\sigma_{ij}^2 \Omega_{ij}^{(2,2)*}$ – effective cross sections of the gas particle collisions.

Given that $2M_1 = M_2$, and introducing the concept of the relative cross section of the particles $\beta_1^2, \beta_{12}^2, \beta_2^2$ V.S. Yargin [2; 3] for a pair of alkali metals received:

$$\eta_{cm} = \eta_1 \frac{1+b_{1\eta} \cdot x_2 + b_{2\eta} \cdot x_2^2}{1+a_{1\eta} \cdot x_2 + a_{2\eta} \cdot x_2^2}, \quad (25)$$

where

$$a_{1\eta} = 2 \left(0,5\sqrt{3} \beta_{12}^2 + \frac{9\sqrt{6}}{40} A_{12}^* \beta_{12}^2 - 1 \right) / (1 + 0,3A_{12}^*), \quad (26)$$

$$a_{2\eta} = -(a_{1\eta} + 1) + 0,5\sqrt{2} (1 + 1,2A_{12}^*) \beta_2^2 / (1 + 0,3A_{12}^*), \quad (28)$$

$$b_{1\eta} = -1,8A_{12}^* \left(1 - 0,5\sqrt{2} \beta_{12}^2 - \frac{\sqrt{4}}{4} A_{12}^* \beta_1^2 \right) / (1 + 0,3A_{12}^*), \quad (29)$$

$$b_{2\eta} = -b_{1\eta} + 0,9A_{12}^* (1 + 0,3A_{12}^*), \quad (30)$$

$$\beta_{12}^2 = \frac{\sigma_{12}^2 \Omega_{12}^{(2,2)*}}{\sigma_1^2 \Omega_{11}^{(2,2)*}}, \quad (31)$$

$$\beta_1^2 = \frac{\sigma_{12}^2 \Omega_{12}^{(2,2)*}}{\sigma_2^2 \Omega_{22}^{(2,2)*}}, \quad (32)$$

$$\beta_2^2 = \frac{\sigma_2^2 \Omega_{22}^{(2,2)*}}{\sigma_1^2 \Omega_{11}^{(2,2)*}}, \quad (33)$$

$$\beta_{12}^2 = \beta_1^2 \cdot \beta_2^2, \quad (34)$$

$$2\beta_{12}^2 = \beta_2^2 + 1, \quad (35)$$

Subsequently, given that the alkali metals in the gas phase, the molar fraction of molecules $x_2 \ll 1$, having decomposed (25) in a row on a small parameter x_2 in [2; 3], we obtained:

$$\eta(x_2, T) = \eta_1(T) \left(1 + \sum_{n=1}^m A_n x_2^n \right) \quad (36)$$

where A_n it is determined by the ratios:

$$\left. \begin{aligned} A_1 &= -a_{1\eta} + b_{1\eta}; A_2 = -a_{1\eta} A_1 + b_{2\eta} - a_{2\eta} \\ A_n &= a_{1\eta} A_{n-1} - a_{2\eta} A_{n-2}; n \geq 3 \end{aligned} \right\}, \quad (37)$$

Given that $A_{12}^* = 1,2$ [5; 22], we have:

$$a_{1\eta} = 1,2735\beta_{12}^2 + 0,9724\beta_1^2 - 2, \quad (38)$$

$$a_{2\eta} = -(a_{1\eta} + 1) + 1,286\beta_2^2, \quad (39)$$

$$b_{1\eta} = +1,5852 + 1,3754\beta_{12}^{-2} + 0,9724\beta_1^{-2} - 2, \quad (40)$$

$$b_{2\eta} = 0,794 - b_{1\eta}, \quad (41)$$

From (36) we have that the excess viscosity due to the contribution of the diatomic vapor molecules is:

$$\frac{\eta - \eta_1}{\eta_1} = \frac{\Delta\eta}{\eta_1} = \sum_{n=1}^m A_n x_2^n, \quad (42)$$

Limiting in the equation (42) the first term, we have:

$$\frac{\Delta\eta}{\eta_1} = A_1 x_2. \quad (43)$$

The first approximation (43) has a clear physical meaning: the viscosity phenomenon is determined by the cross sections of the «atom-atom» and «atom-molecule» collisions, and the difference between the viscosity of the mixture and the viscosity of a monoatomic pair is determined only by the relative cross sections of the «atom-molecule» collisions β_{12}^2 . The sign A of the coefficient characterizes the effect of viscosity pressure (dependence of viscosity on pressure, i. e. on the concentration of molecules). If $A < 0$, then with increasing (greater pressure) viscosity increases $\Delta\eta > 0$. When $A < 0$ viscosity decreases with increasing pressure $\Delta\eta < 0$. If $A = 0$, regardless of the pressure, at the same time $\beta_{12}^2 = \beta_{12critikal}^2$. It follows from the equations (37) and (43):

$$\beta_{12critikal}^2 = 1.21, \quad (44)$$

The second term of the equation (42) takes into account the contribution of the intermolecular interactions that are determined β_{12}^2 , and the third and subsequent terms of the equation refine the physical picture without making qualitative changes [3].

Thus, the obtained theoretical results determine the viscosity of the alkali metal pair as a function of the absolute cross sections of the «atom-atom» $\sigma_{11}^2 \Omega_{11}^{(2,2)*}$ collisions and the relative «atom-molecule» collisions β_{12}^2 . Thus, the series according to x_2 (42) is a very convenient mathematical tool that allows processing, comparison and analysis of the various experimental data on the viscosity of alkali metals in the gas phase.

The viscosity of a single-volume pair η_1 in a wide temperature range is linearly dependent on temperature:

$$\eta_1(T) = \eta_0 + A(T - 1000). \quad (45)$$

The viscosity of a monoatomic pair $\eta_l(T)$ and the effective cross sections of the atomic $\sigma_{11}^2 \Omega_{11}^{(2,2)*}(T)$ collisions are related by the ratio:

$$\eta_l(T) \cdot 10^7 = \frac{26,693 \sqrt{\mu T}}{\sigma_{11}^2 \Omega_{11}^{(2,2)*}(T)} \quad (46)$$

To determine the unknown parameters η_0, A, β_{12}^2 , you need to minimize the target function

$$F(\eta_0, A, \beta_{12}^2) = \sum_{i=1}^N \frac{1}{\Delta \eta_i^2} (\eta_i - \eta_{Ti})^2, \quad (47)$$

where η_i – is the experimental viscosity value, $\Delta \eta_i$ – is the i viscosity error, η_{Ti} – is the viscosity value calculated from the ideal dissociating gas scheme [2].

$$\eta_{Ti} = \left[\eta_0 + A(T-1000) \frac{1 + b_{1\eta} x_2 + b_{2\eta} x_2^2}{1 + a_{1\eta} x_2 + a_{2\eta} x_2^2} \right], \quad (48)$$

$\sigma_{11}^2 \Omega_{11}^{(2,2)*}$ where x_2 – the molar fraction of diatomic molecules in the pair $a_{1\eta}, a_{2\eta}, b_{1\eta}, b_{2\eta}$ – coefficients determined by the cross sections of the collisions «atom-atom» and «atom-molecule» β_{12}^2 [2].

The results of minimizing the target function $F(\eta_0, A, \beta_{12}^2)$ for experimental data [59; 69] at the dissociation energy of molecules of cesium $D_{0Cs}^0 = 44380 \pm 1000$ J/mol [45] and rubidium $D_{0Rb}^0 = 48570 \pm 1000$ J/mol [45] are shown in the table 7.

Table 7

The results of the experimental data processing

Metal	Coefficients of the equation 3		β_{12}^2	$\Delta \eta, \%$	$\Delta A, \%$	$\Delta \beta_{12}^2, \%$
	$\eta_0 \cdot 10^7, Pa \cdot s$	$A \cdot 10^7, Pa \cdot s / K$				
Cs	292,4	0,256	2,2	1,8	2,4	5,2
Rb	268,4	0,233	2,3	2,1	3,0	6,5

The viscosity of a monoatomic pair in the temperature range 700-2000 K is described by the equations:

$$\eta_l(T)_{Cs} = 292,4 + 0,256(T-1000), Pa \cdot s, \quad (49)$$

$$\eta_l(T)_{Rbs} = 268,4 + 0,233(T-1000), Pa \cdot s. \quad (50)$$

Let's calculate the effective cross sections of the collisions of the atoms $\sigma_{11}^2 \Omega_{11}^{(2,2)*}(T)$ for the pair *Cs* and *Rb*. According to the equation (5) we have:

T, K		700	900	1000	1100	1200	1300	1500	1700	1800
$\sigma_{11}^2 \Omega_{11}^{(2,2)*}, A^{\circ 2}$	<i>Cs</i>	37,8	34,6	33,3	32,1	31,0	30,1	28,4	26,9	26,3
	<i>Rb</i>	32,9	30,2	29,1	28,1	27,1	26,3	24,8	23,6	23,0

In the temperature range 700 ... 2000 K, the dependence of the effective cross sections of the «atom-atom» collisions on the temperature is approximated by the equations:

$$\left. \begin{aligned} \sigma_{11}^2 \Omega_{11}^{(2,2)*}(T)_{Cs} &= 54.7 - 32.5 \frac{T}{1000} + 13.29 \left(\frac{T}{1000} \right)^2 - 2.22 \left(\frac{T}{1000} \right)^3, \quad A^{\circ 2} \\ \sigma_{11}^2 \Omega_{11}^{(2,2)*}(T)_{Rb} &= 41.7 - 26.8 \frac{T}{1000} + 10.50 \left(\frac{T}{1000} \right)^2 - 1.69 \left(\frac{T}{1000} \right)^3, \quad A^{\circ 2} \end{aligned} \right\}$$

The dependence of the relative cross sections of the «atom-molecule» β_{12}^2 collisions on the temperature could not be established because the error $\Delta \beta_{12}^2$ is too large. It is easy to show that to reduce it to 5 %, it is necessary to significantly expand the investigated pressure range $\Delta P \sim 1...2 \text{ mPa}$ and increase the accuracy of the input experimental data of the alkali metal vapor viscosity to 1 ... 2 %, which is currently a rather complex scientific and technical problem.

5. Generalization of the experimental results

According to the theory of the transfer phenomena, the viscosity and thermal conductivity of the alkali metals in the gas phase are a function of the absolute cross sections of the collisions «atom-atom» $\sigma_{11}^2 \Omega_{11}^{(2,2)*}$ and relative – «atom – molecule» β_{12}^2 . Thus, the theory [2; 3] makes it possible to process, compare and analyze a variety of experimental data on the viscosity of the alkali metals in the gas phase.

The theory of the thermal conductivity of the chemically reactive gas mixtures is based on the fact that the thermal conductivity of such a mixture is given in the form [2]:

$$\lambda = \lambda_f + \lambda_r, \tag{51}$$

where: λ_f the component of the thermal conductivity without taking into account the effect of the chemical reaction on the heat transfer process (the frozen component of thermal conductivity), λ_r the component of the thermal

conductivity due the energy transfer as a result of the reactions («reaction» component of the thermal conductivity).

The «reaction» component of the thermal conductivity is [2]:

$$\lambda_r = \frac{D_{12}P}{T} \left(\frac{D_0(T)}{RT} \right)^2 \frac{x_1 x_2}{(1+x_2)^2}, \quad (52)$$

$$D_0(T) = D_0^0 + 2H_1(T) - H_2(T), \quad (53)$$

where D_0^0 the energy of dissociation at the temperature $T = 0$, $H_1(T)$ and $H_2(T)$ – the enthalpy of the atomic and molecular components at the temperature T .

The «frozen» component of the thermal conductivity of the alkali metal vapor is served as a sum

$$\lambda_f = \lambda_{tr} + \lambda_{int}, \quad (54)$$

where λ_{int} the thermal conductivity due to the internal degrees of freedom of the interacting particles; λ_{tr} thermal conductivity due to the energy transfer caused by the translational degrees of freedom.

According to [2]

$$\lambda_{int} = \frac{nD_{22}(C_{p,2} - \frac{5}{2}R)}{1 + \frac{x_1}{x_2} \frac{D_{22}}{D_{11}}}, \quad (55)$$

where $C_{p,2}$ the specific heat at constant pressure, R caused by the universal gas constant.

$$\frac{1}{\lambda_{\Pi}} = \frac{X_{\lambda} + Y_{\lambda}}{1 + Z_{\lambda}}, \quad (56)$$

$$X_{\lambda} = \frac{1}{\lambda_{11}} x_1^2 + \frac{2x_1 x_2}{\lambda_{12}} + \frac{1}{\lambda_{22}} x_2^2, \quad (57)$$

$$Y_{\lambda} = \frac{1}{\lambda_{11}} V^{(1)} + \frac{2x_1 x_2}{\lambda_{12}} V^{(Y)} + \frac{1}{\lambda_{22}} x_2^2 V^{(2)}, \quad (58)$$

$$Z_{\lambda} = x_1 V^{(1)} + 2x_1 x_2 V^{(Z)} + x_2^2 V^{(2)}, \quad (59)$$

$$\lambda_{ij} \cdot 10^4 = 833 \sqrt{\frac{T(M_1 + M_2)}{2M_1 M_2}} \frac{1}{\sigma_{ij}^2 \Omega_{ij}^{(2,2)*}} \quad (i, j = 1, 2), W/(m \cdot K), \quad (60)$$

where:

$$\left. \begin{aligned} V^{(r)} &= 0,3A_{12}^* \frac{\lambda_{12}^2}{\lambda_1 \lambda_2} - V^{(3)} \\ V^{(1)} &= \frac{4}{15} A_{12}^* + \frac{1}{10} B_{12}^* + \frac{5}{24} \\ V^{(2)} &= \frac{4}{15} A_{12}^* - \frac{2}{5} B_{12}^* + \frac{1}{12} \\ V^{(3)} &= \frac{1}{5} B_{12}^* + \frac{3}{16} \frac{B_{12}^*}{A_{12}^*} + \frac{25}{64} \frac{1}{A_{12}^*} + \frac{1}{12} \\ V^{(4)} &= \frac{4}{15} A_{12}^* + \frac{1}{5} B_{12}^* + \frac{1}{12} \end{aligned} \right\} \quad (61)$$

$$A_{12}^* = \frac{\Omega_{12}^{(2,2)*}}{\Omega_{12}^{(1,1)*}}, \quad (62)$$

$$B_{12}^* = \frac{5\Omega_{12}^{(1,2)*} - 4\Omega_{12}^{(1,3)*}}{\Omega_{12}^{(1,1)*}}. \quad (63)$$

The thermal conductivity associated with the transfer of energy due to the translational degrees of freedom of the particles is [2; 3]:

$$\lambda_{tr} = \lambda_1 \frac{1 + b_{1\lambda} x_2 + b_{2\lambda} x_2^2}{1 + a_{1\lambda} x_2 + a_{2\lambda} x_2^2}, \quad (64)$$

where λ_1 the thermal conductivity of the monoatomic vapor.

The thermal conductivity due to the contribution of the internal degrees of freedom of the particles is [2; 3]:

$$\lambda_{int} = \lambda_1 \frac{4\sqrt{3}}{25} A_{12}^* \frac{2C_{p,2} - 5R}{2R} \frac{x_2}{1 - \left(1 - \frac{D_{21}}{D_{22}} x_2\right)}, \quad (65)$$

$$\frac{D_{21}}{D_{22}} = \frac{\sqrt{6} A_{12}^*}{2 A_{22}^* \beta_{12}^2}, \quad (66)$$

The «reaction» component of the thermal conductivity is:

$$\lambda_r = \lambda_1 \frac{0,2771 A_{12}^*}{B_{12}^*} \left(\frac{D_0(T)}{RT} \right)^2 \frac{x_2(1-x_2)}{(1+x_2)^2}, \quad (67)$$

Where

$$\left. \begin{aligned} a_{1\lambda} &= \frac{4\sqrt{3}}{3} \cdot \frac{1-V^{(3)}}{1-V^{(1)}} \beta_{12}^2 + 0,3\sqrt{6} \frac{A_{12}^*}{1+V^{(1)}} \beta_1^2 \\ a_{2\lambda} &= -(a_{1\lambda} + 1) + \sqrt{2} \frac{1+V^{(2)}}{1+V^{(1)}} \beta_2^2 \\ b_{1\lambda} &= -2 \frac{V^{(1)} \cdot V^{(4)}}{1+V^{(1)}} + 0,3\sqrt{3} \frac{A_{12}^*}{1+V^{(1)}} \beta_{12}^2 \\ b_{2\lambda} &= - \left(b_{1\lambda} \cdot \frac{V^{(1)} \cdot V^{(2)}}{1+V^{(1)}} \right) \end{aligned} \right\} \quad (68)$$

$$A_{22}^* = \frac{\Omega_2^{(2,2)*}}{\Omega_2^{(1,1)*}}, \quad (69)$$

When $A_{22}^* = 1,2$ and $B_{12}^* = 1,2$ we have:

$$\left. \begin{aligned} a_{1\lambda} &= 1,3359\beta_{12}^2 + 0,6262\beta_1^2 - 2 \\ a_{2\lambda} &= -(a_{1\lambda} + 1) + 0,9272\beta_2^2 \\ b_{1\lambda} &= 1,4936 + 0,4428\beta_{12}^2 + 0,6262\beta_1^2 \\ b_{2\lambda} &= -(b_{1\lambda} + 0,3445) \end{aligned} \right\} \quad (70)$$

Having laid out expressions (64) and (65) in a row on a small parameter x_2 Yargin V.S. received [2, 3, 24, 68]:

$$\lambda(x_2, T) = \lambda_1(T) \left\{ 1 + \sum_{n=1}^m B_n x_2^n + B_p \left(\frac{T_p}{T} \right)^2 \frac{x_2(1-x_2)}{(1+x_2)^2} \right\}, \quad (71)$$

where

$$B_p = 0,3335\beta_{12}^2, \quad (72)$$

$$B_n = B_n^{(n)} + B_n^{(BH)}, \quad (73)$$

$$\left. \begin{aligned} B_1^{(n)} &= -a_{1\lambda} + b_{1\lambda} \\ B_2^{(n)} &= -a_{1\lambda} B_1^{(n)} - a_{2\lambda} b_{2\lambda} \\ &\dots \dots \dots \\ B_n^{(n)} &= -a_{1\lambda} B_{n-1}^{(n)} + a_{2\lambda} B_{n-2}^{(n)}, n \geq 3 \\ B_1^{(BH)} &= 0,3325\beta_{12}^2 \left(\frac{C_{p,2}}{R} - \frac{5}{2} \right) \\ &\dots \dots \dots \\ B_n^{(BH)} &= B_1^{(BH)} (1-1,2248\beta_1^2)^{n-1} \end{aligned} \right\} \quad (74)$$

$$T_p = \frac{D_0(T)}{R}. \quad (75)$$

Equations (70) – (75) show that the coefficients B of the series for x_2 the viscosity and thermal conductivity of the alkali metal vapors depend only on the absolute cross-sections of the «atom-atom» $\Omega_{11}^{(2,2)*}$ collisions and the relative cross-sections of the «atom-molecule» collisions β_{12}^2 .

Thus, the theory we considered [2; 3; 24; 68] makes it possible to process and compare the results of the experimental studies of the viscosity and thermal conductivity of the alkali metal vapor. Excess relative viscosity and thermal conductivity can be given as functions of the molar fraction of the molecular component x_2 , and the coefficients of the approximating polynomial are known as the functions of the collision cross sections. Approximating equations (36), (71) make it possible to carry out a reasonable extrapolation of the coefficients of the viscosity and thermal conductivity of the alkali metal vapor outside of the experimental studies, as well as to establish the relationship between the viscosity and thermal conductivity through the particle collisions. For a monoatomic pair of the alkali metals from (1.5) and (1.35) we have [2; 24].

$$\frac{\lambda_1(T)}{\eta_1(T)} = \frac{0,312 \cdot 10^5}{M}. \quad (76)$$

We compare our cross-sections of the particle collisions with the literature data on the viscosity and thermal conductivity of cesium and rubidium in the gas phase.

A large number of works performed by various methods have been devoted to the experimental study of the alkali metal vapor viscosity. Almost all of them are limited to a temperature of 1800 K. The viscosity of steam at high temperatures was studied in only two studies [6; 8]. The analysis of the results of studies of the viscosity and thermal conductivity of cesium and rubidium vapor was performed in [2; 3; 68]. Most alkali metals with increasing pressure are characterized by an increase in thermal conductivity and a decrease in viscosity. The data of different authors on these coefficients, as a rule, agree well with each other. And only cesium falls out of the general picture, for him the results of experimental studies on the viscosity of different authors differ in the sign of the pressure effect, and in the thermal conductivity – in the magnitude of this effect.

The work is devoted to the experimental study of the viscosity of the cesium vapor [2; 3; 14; 18; 19; 20; 21; 22; 23; 48; 65; 71; 72].

Henson R. M., Stratton T. E., Toodd J. [22] conducted a study of the viscosity of the cesium vapor by the method of a straight capillary at $T = 600 \dots 1000$ K, the experimental data are described by the equation:

$$\eta = (2,5 \pm 0,5) \cdot 10^{-7} \left(\frac{T}{650} \right)^{0,7}, \text{ Pa} \cdot \text{s} \quad (75)$$

According to the authors, the error is $\pm 20\%$, the obtained experimental values of the viscosity are not given. The method of the experiment and the design of the installation are not described.

Lee D.I., Bonilla S.F. [18; 19] measured the viscosity coefficient of cesium vapor in the temperature range of 950 ... 1280 K at pressures of 40 ... 500 kPa using the spiral viscometer method. Two series of experiments were conducted, more than 70 experimental points were obtained, which are presented in the graphical form. The dependence of the viscosity on pressure is ambiguous. At the temperatures below 1080 K the vapor viscosity decreases with increasing pressure, and at the high temperatures increases. The authors point to a large scatter of experimental data of about 20 %. The smallest deviation is characterized by the points obtained at the atmospheric pressure, for which the smoothed data are described by the equation:

$$\eta \cdot 10^7 = -648,14 + 1511,52 \left(\frac{T}{1000} \right) - 628,65 \left(\frac{T}{1000} \right)^2, \text{ Pa} \cdot \text{s} \quad (76)$$

In the experiments [18; 19], the pressure drop across the capillary was set using an intermediate inert gas and measured with a differential manometer. The investigated cesium vapor came from the evaporator into the capillary, and then condensed in the flow meter. The measured volume of the flowmeter was pre-calibrated according to the height of the working area.

The geometric factor of the capillary was determined after its installation on the set place on experiments with argon. The viscosity of the cesium vapor was calculated by the Poiseuille formula taking into account:

- a) correction for the curvature of the capillary;
- b) slip correction;
- c) correction for thermal expansion of the capillary;
- d) correction for energy losses at the input.

To reduce the correction for the curvature of the capillary experiments were performed at the pressure drops in the working area, ensuring compliance with the Dean criterion:

$$Re \cdot \sqrt{d/D} \leq 6, \quad (78)$$

where Re – is the Reynolds number,

d – is the inner diameter of the capillary,

D – is the average diameter of the spiral.

In the first series of experiments, a capillary made of *S* 304 steel with an inner diameter of 0,822 mm was used. The viscosity of the cesium vapor in the temperature range 950 ... 1210 K at the atmospheric pressure was studied. Since the installation did not provide a system for distilling the liquid alkali metal from the flowmeter into the evaporator, after each cycle of experiments, the metal was distilled from the flowmeter into the evaporator – through a capillary. The second series of experiments provided a system for the distilling condensate from the flow meter into the evaporator, which in general increased the service life of the installation. A capillary made of Haines-25 alloy was used. In this series of experiments, the main array of the experimental viscosity values was obtained. In the installation, as the authors point out, during the second series of experiments there was a microcrack, the capillary was subjected to corrosion.

Tippetskirch H.V. [21] studied the viscosity of the cesium vapor at the temperatures of 1602-1622 K and a pressure of 3,95 mPa. 4 experimental points near the saturation line were obtained. In the experiments [21], the purified cesium was placed in a vessel made of tungsten-rhenium alloy. The inner diameter of the vessel is $6,755 \pm 0,005$ mm, the height of the working part is $13,032 \pm 0,01$ mm. The mass of the filled metal was determined by weighing the vessel before and after filling and was $0,0913 \pm 0,005$ g. Then the vessel was mounted on a suspension, heated and brought to a state of torsional vibrations. The vapor viscosity was determined by the magnitude of the decrement of the damping attenuation of the vessel with the cesium gas.

The pressure in the experiments [21] was determined by the elasticity curve, the errors of the experimental data according to the authors are 5 %.

In the group of thermophysics MAI under the leadership of the Professor Vargaftik N. B. the viscosity of the cesium vapor in the temperature range 900 ... 1200 K at pressures of 50 ... 250 kPa was studied by the method

of a straight capillary [2; 3; 20; 25; 23; 25]. The installation was a closed circulation circuit made of stainless steel. The investigated metal vapor from the evaporator through the steam heater entered the steam dehumidifier, took the temperature of the experiment and passed through the capillary. After leaving the capillary, the steam condensed in the refrigerator and flowed into a U-shaped flowmeter. The flowmeter temperature was kept constant by means of a liquid thermostat. Condensate flow was determined by the time of passage of the metal level between the two contact needles of the flow meter, which were at different heights. The pressure difference at the measuring section of the viscometer was set through the intermediate inert gas and was measured with an oil manometer. Capillary outlet pressure was measured with a mercury manometer. The installation provided the ability to control the geometric factor of the capillary during experiments without draining the metal from the measuring element. The calculation of the viscosity of the cesium vapor was performed according to the Poiseuille formula with the corrections for the gas compressibility, inlet pressure loss, molecular slip and thermal expansion of the capillary.

32 experimental points were obtained in the work, experiments were performed on isobars. As a result, the viscosity of the cesium vapor decreases with increasing pressure. The authors estimate the accuracy of the obtained data at 2,5 %. Processing the results [2; 14; 25] gives:

$$\left. \begin{aligned} \eta_1 \cdot 10^7 &= 258 + 0,220(T-900), \text{Pa} \cdot \text{s} \\ \eta &= \eta_1 (1 - 1.65x_2 + 3x_2^2), \text{Pa} \cdot \text{s} \end{aligned} \right\} \quad (79)$$

that corresponds β_{12}^2 .

At the Moscow Aviation Institute under the direction of Professor Vargaftik N. B. the viscosity of the cesium vapor was studied by means of a viscous meter with an annular channel. 167 values of the vapor viscosity in the temperature range 900-1770 K at pressures of 12-135 kPa were obtained (Vargaftik N. B., Dzis V. G., Stepanenko I. S., Yargin V. S.) [59; 65; 69; 70; 71; 72; 74; 77].

According to [18; 19], the viscosity of the atomic component is 12-15 % lower than according to the results [24; 25]. The intersections of the collisions of atoms, calculated by [18; 19], increase with temperature, which indicates a qualitative illegality of the dependence $\eta(T)$.

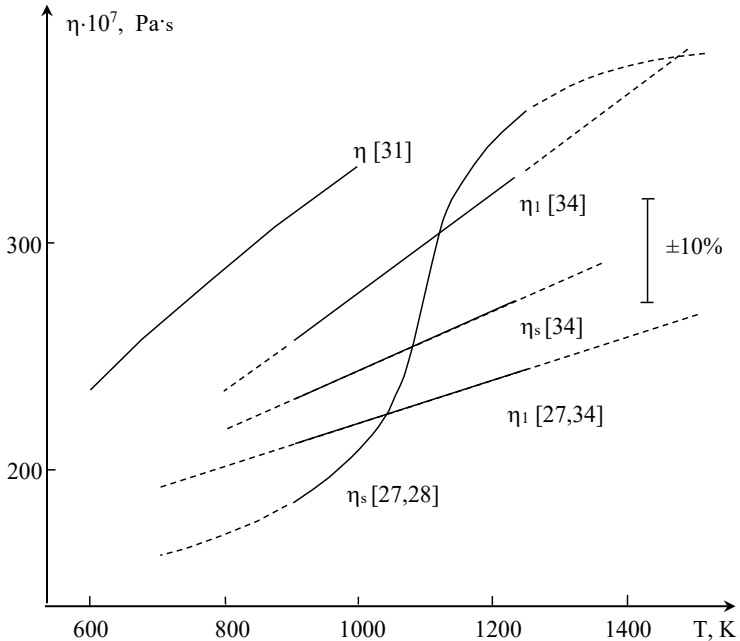

Figure 8. The viscosity of cesium in the gas phase according to the works [18; 19; 22; 23; 24; 25]

The negative effect of pressure [19] at $T > 1050$ K corresponds $\beta_{12}^2 \geq 2$, and its positive sign at $T > 1080$ K – $\beta_{12}^2 < 1,2$.

Rubidium. Two works have been devoted to the experimental study of the viscosity of rubidium in the gas phase [28; 34].

In [19] Bonilla C.F., Lee D.I. eliminating the shortcomings and methodological inaccuracies of the installation, discovered during the experiments with the cesium vapor, conducted a study of the viscosity of the rubidium vapor in the temperature range of 930 ... 1230 K at pressures of 47 ... 200 kPa. The capillary of the viscometer was calibrated with argon before and after the experiments with the rubidium vapor. No changes in the geometric factor of the capillary during the experiments were detected. In [19], 49 experimental values of the viscosity of the rubidium vapor were obtained, which are shown graphically.

At a pressure of 100 kPa, the dependence of the viscosity on temperature, the authors [19] describe with the equation:

$$\eta \cdot 10^7 = -850,381 + 1644,192 \frac{T}{1000} - 575,617 \left(\frac{T}{1000} \right)^2, \text{ Pa} \cdot \text{s} \quad (80)$$

The negative effect of the pressure is established and the tables of the viscosity of the rubidium vapor in the temperature range 700-1500 K at pressures up to 500 kPa are developed. The dependence of the viscosity of a monoatomic pair on the temperature is described by the equation:

$$\eta_1 \cdot 10^7 = 241 + 0,300(T-1000), \text{ Pa} \cdot \text{s} \quad (81)$$

Processing of the experimental data of the work considered above in [5] gives:

$$\left. \begin{aligned} \eta_1 \cdot 10^7 &= 241 + 0,300(T-1000), \text{ Pa} \cdot \text{c} \\ \Delta\eta &= -2,08x_2 + 4,2x_2^2 - 8,4x_2^3 \\ \beta_{12}^2 &= 2,4 \end{aligned} \right\} \quad (82)$$

M.I. Sidorov, Yu.V. Tarlakov, V.S. Yargin [25] conducted a study of the viscosity of the rubidium vapor by the viscometer with a straight line. 27 experimental values of the viscosity at $T = 900 \dots 1180$ K and $P = 40 \dots 150$ kPa were obtained, the authors estimate the accuracy of the obtained data at $\pm 2,5\%$.

The experiments [25] were performed on isobars 39, 76, 153 kPa. When processing the experimental data by extrapolation from the isotherms of the dependence at $x_2 \rightarrow 0$, the viscosity of the monoatomic pair was determined η_1 and the dependence was found, $\left(\frac{\eta_{\text{эксп}} - \eta_1}{\eta_1} \right)$, which was approximated by a second-order polynomial. The results of the processing give:

$$\left. \begin{aligned} \eta_1 \cdot 10^7 &= 239 - 0,210(T-900), \text{ Pa} \cdot \text{c} \\ \eta &= \eta_1(1 - 2,25x_2 + 5x_2^2) \end{aligned} \right\} \quad (83)$$

More accurate data processing [25] in [2; 3; 14] at the dissociation energy of the molecules $D_0^\circ = 48570$ J/mol gives:

$$\left. \begin{aligned} \eta_1 \cdot 10^7 &= 259 - 0,202(T - 1000), \text{ Pa} \cdot \text{c} \\ \frac{\Delta\eta}{\eta_1} &= -2,13x_2 + 4,4x_2^2 - 9x_2^3 \end{aligned} \right\} \quad (84)$$

that corresponds $\beta_{12}^2 = 2,44$.

Thus, in [19; 25] similar values of the cross sections of the «atom-molecule» collisions were obtained, and the values η_1 and their dependence on temperature differ slightly. The difference between η_1 in the above mentioned works does not exceed 9 % (Figure 9).

Later, the Moscow Aviation Institute conducted a study of the viscosity of the cesium vapor using a annular-type viscometer. 61 values of the viscosity of the rubidium vapor in the temperature range 990-1750 K at pressures of 39-135 kPa (Vargaftik N.B., Yargin V.S., Dzis V.G., Stepanenko I.S.) were obtained [66; 69; 72; 71; 77].

The viscosity and thermal conductivity of the alkali metal vapors are uniquely related through the cross sections of the collisions of the particles σ_{11}^2 and β_{12}^2 . This allows us to jointly consider the experimental work with

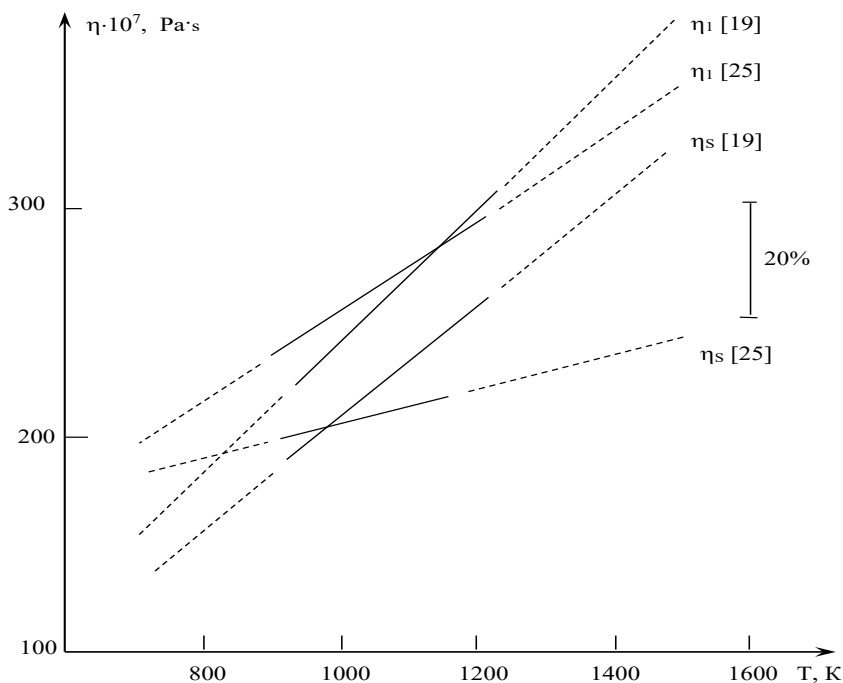

Figure 9. The viscosity of rubidium in the gas phase according to [19; 25]

these coefficients. Therefore let's consider the results of the experimental studies of the thermal conductivity, which can be used in the analysis of the viscosity data.

Information on experimental studies of the thermal conductivity of cesium in the gas phase are shown in the table 8.

Table 8

Experimental work on the thermal conductivity of cesium vapor

Authors	Lit. source	Interval		Method
		Temperature, K	Pressure, kPa	
Gottlieb M., Zollweg R.I.	[27]	950...1150	to 5.1	Combined method of flat layer and heated thread
Kitrilakis S., Meeker M.	[28]	1100...1400	to 67	Flat thermoionic converter
Martini W.R.	[29]	1240...1260	to 4	Flat thermoionic converter
Zarkova L.P., Stefanov B.I.	[12]	1000...2400	1...7	Modified method of heated thread
Zarkova L.P., Stefanov B.I.	[30]	600...1600	1...7	Modified method of heated thread
Lee D.I., Bonilla C.F.	[31]	820...888	98...216	Periodic heating
Vargaftik N.B., Kerzhentsev V.V.	[32]	680...1080	10...130	Coaxial cylinders
Timroth D.L., Makhrov V.V., Sviridenko V.I., Reutov B.F.	[33]	800...1100	1.4...247	Heated thread with zero area
Vinogradov Yu.K., Veryugin A.V.	[13]	1120...1170	100...150	Periodic heating
Vinogradov Yu.K.	[34]	998...1707	12...195	Monotonous heating
Vinogradov Yu.K.	[39]	1000...1600	5...200	Monotone thermal mode method (automated version)

According to the results of [39], the dependence of the thermal conductivity of the cesium vapor on temperature is described by the equation:

$$\lambda_1 \cdot 10^4 = 15,2 + 59,7T, W/(m \cdot K),$$

$$\beta_{12}^2 = 1,8.$$

The effect of pressure and magnitude β_{12}^2 can be judged by the data of works [13; 32; 34; 39], and the thermal conductivity of the atomic component by works [13; 32; 34; 39]. Dependencies $\lambda_1(T)$ and $\lambda_s(T)$ are shown in Figure 9.

The effective cross sections of the collisions of the atoms in works [22; 33; 34] are well coordinated with each other. The largest discrepancy in the cross sections is 5,5 %, i. e. is within the experimental errors. The data of the works [12; 30] differ by 10 ... 12% from the data [22; 33]. This discrepancy is explained by the fact that at the pressures of the experiments [12; 30] the free path length of atoms is close to the radius of the filament of the experimental installation and even exceeds it. Under such conditions, the Fourier heat equation needs to be clarified.

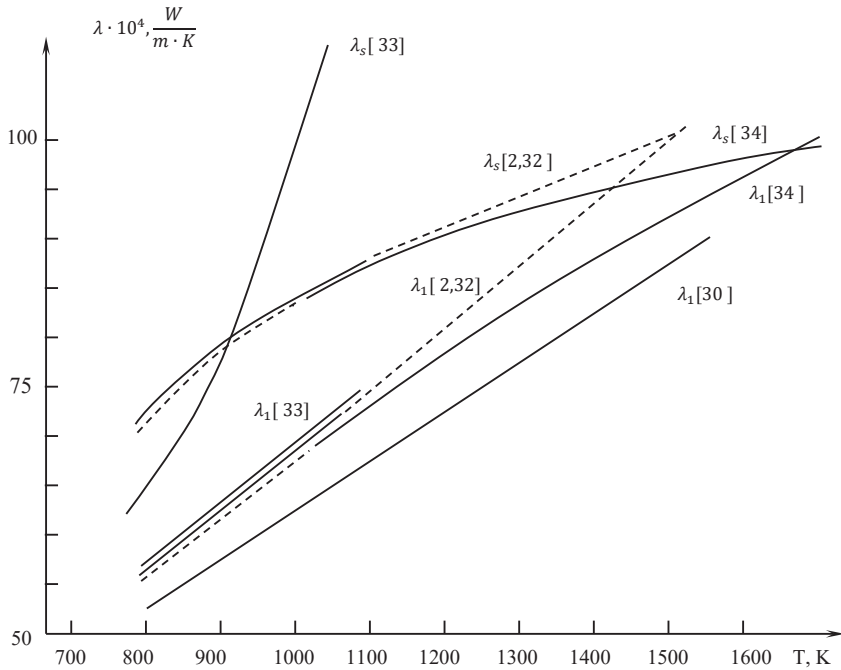

Figure 9. Thermal conductivity of cesium in the gas phase according to [2; 30; 32; 39; 33; 35; 34]

The value of the relative cross section β_{12}^2 , determined by the effect of pressure according to [32], is 2,08, i. e. coincides within the errors with the results [34; 39]. The results [13] also confirm the data [32]. In [33] β_{12}^2 it obviously depends on the temperature and varies from 2,57 at $T = 800$ K to 0,96 at $T = 1100$ K.

Rubidium. Experimental work on the thermal conductivity of the rubidium vapor is shown in the table 9, the results are presented in Figure 10.

Table 9

**Experimental work on the thermal conductivity
of the rubidium vapor**

Authors	Lit. source	Interval		Error, %	Method
		Temperature, K	Pressure, kPa		
Gottlieb M., Zollweg R.I.	[27]	950...1150	to 2,9	30	Combined method of flat layer and heated thread
Lee D.I., Bonilla C.F.	[31]	1045...1099	84...89	6	Periodic heating
Vargaftik N.B., Studnikov E.L.	[36]	800...1110	5...150	4	Coaxial cylinders
Timroth D.L., Makhrov V.V., Reutov B.F.	[37]	900...1100	1.4...130	7	Heated thread with zero area
Vinogradov Yu.K.	[39]	970...1715	1,5...75	5-6	Monotone thermal mode method (automated version)

The first experimental works [27; 31] have methodological inaccuracies, which have been repeatedly discussed in the literature [2, 4]. The results of [36; 37; 39] with an accuracy of 2 ... 3% are consistent with each other, which is much less than the error of the experiments. The effective cross sections of the atoms $\sigma_{11}^2 \Omega_{11}^{(2,2)*}$, the temperature dependence $\lambda_1(T)$ and the value of the relative cross section «atom – molecule» β_{12}^2 according to the data of these works are close.

Analyzing experimental work on the thermal conductivity of cesium and rubidium in the gas phases, preference should be given to the work of Vinogradov Yu.K. [39]. The dependence of the thermal conductivity of the monoatomic vapor on temperature is described by the equation:

$$\lambda_1 \cdot 10^4 = 4,9 + 89,5T, W/(m \cdot K).$$

The relative cross sections of the «atom molecule» collisions depend on the temperature:

$$e \beta_{12}^2 = 2,24 - 0,1 \cdot \frac{T}{1000}.$$

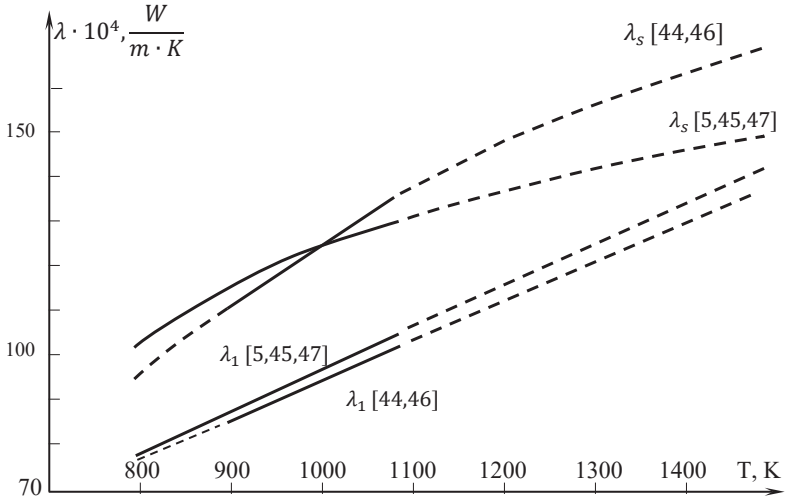

Figure 10. Thermal conductivity of rubidium in the gas phase according to [2; 36; 37]

We compare the obtained cross sections of the cesium and rubidium vapor microparticles with the literature data (Figure 11).

Figure 11 shows that the obtained cross sections of the «atom-atom» $\sigma_{11}^2 \Omega_{11}^{(2,2)*}$ collisions of our work for the Cs pair at $T \leq 1200$ K almost coincide with the results [33] and agree well with the data of RSD 81 [68] tables and average cross-sectional values based on joint processing of the experimental viscosity and thermal conductivity data [2; 3]. With an accuracy of 4 ... 7 %, i. e. within the total error are consistent with the data [25]. At the temperatures up to 1300 K, the cross sections $\sigma_{11}^2 \Omega_{11}^{(2,2)*}$ agree within the total error with the data [34], but with increasing temperature they diverge, and at $T = 1800$ K the discrepancy is 13%. This discrepancy can be explained by the fact that at the temperatures above 1300 K for the cesium vapors

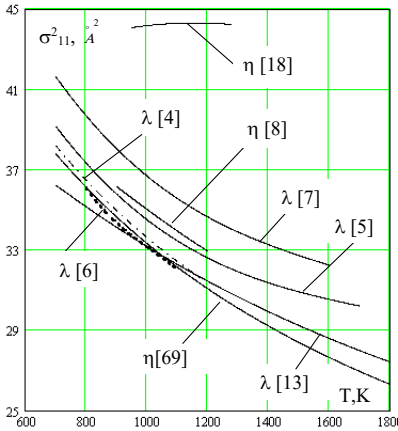

Figure 11. Effective collision cross sections atoms in the cesium pair

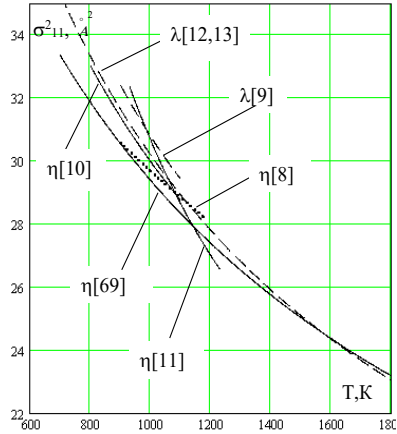

Figure 12. Effective sections of collisions rubidium pair atoms

$(\lambda_s - \lambda_1) / \lambda_1 \sim 5 \dots 10 \%$ [2], and in the field of the experimental parameters [34] $(\lambda_s - \lambda_1) / \lambda_1 \sim 1,0 \dots 3,0 \%$, with the total error of the experiment $\lambda \sim 6\%$ and a small array of the experimental values, it is impossible to obtain sufficiently accurate intersections of collisions $\sigma_{11}^2 \Omega_{11}^{(2,2)*}$.

In addition, as shown in the paragraph 1.4, at high temperatures in the experiments on the thermal conductivity, it is necessary to introduce many different corrections, taking into account a number of side effects, which reduces the accuracy of the final results. In general, the results [34] qualitatively correctly reflect the general patterns of the transfer processes in the cesium vapors.

The effective collision cross sections $\sigma_{11}^2 \Omega_{11}^{(2,2)*}$ for the *Rb* pair (Figure 12) according to the results of this work are consistent in the common areas of experiments at $T \leq 1200$ K with the results of [18; 25; 39; 45] and differ from some of them in the field of extrapolation. Depending on the temperature of the collisions $\sigma_{11}^2 \Omega_{11}^{(2,2)*}$ for all works on the viscosity and thermal conductivity of the *Rb* vapor are different. This is due to the fact that they are all made in a narrow range of temperatures, which does not allow to reliably establish the temperature dependence $\sigma_{11}^2 \Omega_{11}^{(2,2)*}(T)$.

From the experiments on the viscosity of this work we can clearly ascertain a negative effect of the pressure for *Cs* and *Rb* ($\beta_{12}^2 > 1,21$). For all experimental points ($(\lambda - \lambda_1)/\lambda_1 \leq 0$), i. e. the viscosity decreases with the increasing pressure (increasing concentrations of the diatomic molecules x_2).

According to the relative intersections of the collisions β_{12}^2 in the pair *Cs* (Table 10), the data of this work are consistent with the data [25; 32; 34; 39]. Exceptions are works [18; 19; 33], at the temperature $T \sim 1080$ K there is a sharp change in β_{12}^2 . The data from this work do not confirm this effect (see tables 10, 11).

The relative collisions of β_{12}^2 for the pair *Rb* according to the results of our work are consistent with the literature data obtained from the experimental data on the viscosity and thermal conductivity at $T = 700 \dots 1200$ K (Table 12).

Table 10

Relative cross-sections of the β_{12}^2 cesium collisions in the gas phase based on the results of the viscosity and thermal conductivity works ($\Delta\beta_{12}^2 \sim 20\%$)

Source	[18, 19]	[25]	[32]	[33]	[34]	[39]	[69]
β_{12}^2	2,5-1,0	2,08	2,1	2,56-0,96	2,1	1,8	2,2

Table 11

Relative cross-sections of the β_{12}^2 cesium in the gas phase according to the results of the experimental viscosity research [69] ($\Delta\beta_{12}^2 \sim 30\%$)

T, K	914	975	1050	1135	1235	1330
Numeric points	10	15	23	21	23	14
β_{12}^2	2,4	1,9	2,3	2,1	2,6	1,9

Table 12

Relative cross-sections of the β_{12}^2 rubidium collisions in the gas phase based on the results of the viscosity and thermal conductivity works ($\Delta\beta_{12}^2 \sim 20\%$)

Source	[19]	[25]	[36]	[37]	[39]	[69]
β_{12}^2	2,44	2,4	2,21	2,17	$2,24 - 0,1 \frac{T}{1000}$	2,3

Thus, the intersections of the collisions $\sigma_{11}^2 \Omega_{11}^{(2,2)*}$ and β_{12}^2 in the pair *Cs* and *Rb* for $T \leq 1200$ K obtained in this work are in good agreement with most of the experimental works on the viscosity and thermal conductivity. The cross sections $\sigma_{11}^2 \Omega_{11}^{(2,2)*}$ were obtained by us from the processing of the viscosity experiments performed in a wider range of temperatures, which increases the reliability of the dependence $\sigma_{11}^2 \Omega_{11}^{(2,2)*}(T)$. These circumstances allow us to use the cross sections $\sigma_{11}^2 \Omega_{11}^{(2,2)*}$ and β_{12}^2 obtained in this paper to develop the recommended tables of coefficients of the viscosity and thermal conductivity of cesium and rubidium in the gas phase.

Cesium and rubidium have rather low ionization potentials, so various ionization processes can take place in their pair [10; 40; 41; 43]. Let us estimate the contribution of the electronic component λ_e to the thermal conductivity of steam and the ionic component to the viscosity.

In order of magnitude, the effect of the electronic component λ_e on the thermal conductivity is [42]:

$$\frac{\lambda_e}{\lambda_1} = \frac{N_e}{N_a} \frac{\sigma_{11}^2}{\sigma_{e1}^2} \sqrt{\frac{M}{m_e}}, \quad (85)$$

where m_e – the mass of electrons, M – the mass of the atom, N_e and N_a – the concentration of electrons and atoms in the alkali metal vapor, σ_{e1}^2 and σ_{11}^2 the effective cross sections of the collisions «atom-electron» and «atom-atom». For rough estimates we accept $\sigma_{e1}^2 = \sigma_{11}^2$ and we receive (table 13).

Let's evaluate the viscosity of the weakly ionized alkali metal vapor [41; 42]:

$$\eta \sim \frac{\sqrt{T \cdot M}}{\sigma_{11}^2 + \sigma_p^2 \cdot \frac{N_i}{N_a}}, \quad (86)$$

Table 13

**Influence of electronic component on the vapor thermal conductivity
Cs and *Rb***

T, K	Cesium		Rubidium	
	$\lambda_e / \lambda_1, \%$		$\lambda_e / \lambda_1, \%$	
	$P = 1$ kPa	$P = 20$ kPa	$P = 1$ kPa	$P = 20$ kPa
1500	0,8	0,5	0,2	0,15
1800	7,8	1,8	2,6	0,6
2000	40	33	16,9	12,0

where, σ_p^2 – the effective cross section of the resonant ion recharging on the neutral atom, N_i and N_a the concentration of ions and atoms in the pair.

At an ion energy 0,1-0,2 eB $\sigma_p^2 \sim 450 \div 500 \text{ \AA}^2$ [41; 42; 43], therefore, according to the equations (3, 21) the effect of the ionic component on the viscosity of cesium and rubidium vapor at low pressures is:

Table 14

Influence of the ionic component on the vapor viscosity

T, K	Cesium		Rubidium	
	η_e/η_p , %		η_e/η_p , %	
	$P = 0,1 \text{ kPa}$	$P = 1 \text{ kPa}$	$P = 0,1 \text{ kPa}$	$P = 1 \text{ kPa}$
1800	1	0,5	0,4	0,2
2000	6	2	3	0,9

Tables 13 and 14 show that at temperatures up to 2000 K and pressures $P \geq 10 \text{ kPa}$ the influence of the ionization processes on the transfer coefficients of the cesium and rubidium vapor can be neglected, and the vapor of these metals can be considered as a reactive two-component mixture of atoms and diatomic molecules.

Based on the parameters η_0, A, β_{12}^2 obtained in this work, according to the method [2; 3] of equation (19–42, 51–76) the tables of the viscosity and thermal conductivity of the rubidium and cesium vapor in the temperature range 700-2000 K at pressures 1-1500 kPa, including the saturation line were developed the vapor pressure at the saturation line was determined by [51], the vapor composition x_2 (molar concentration of two-volume molecules) by equation [2].

The coefficients of the thermal conductivity and viscosity of cesium vapor are in a good agreement with the data of [2; 3; 14; 32; 36; 39; 46] in their common temperature ranges, the maximum discrepancy does not exceed 5%. Within the total error, the tabular values of η_s and λ_s of our studies are consistent with [75], and η_1 and λ_1 for temperatures of 700... 1500 K. The maximum deviation is 12% at $T > 180 \text{ K}$.

The tabular values of the coefficients of the thermal conductivity and viscosity of the rubidium vapor within the total errors are consistent with the data of [3; 5; 14; 25; 35; 37; 38; 39; 46], the maximum deviation does not exceed 6%.

Thus, the obtained in this paper tabular values of the coefficients of the viscosity of cesium and rubidium vapor in the gas phase, are quite consistent with the literature data for temperatures up to 1500 K.

The tables of the transfer coefficients developed by us are based on the experimental data on viscosity of the cesium and rubidium vapor the experiments have been carried out in a wide range of temperatures 900... 1750 K, which increases the reliability of extrapolation to high temperatures up to 2000 K. These circumstances recommend the developed viscosity and thermal conductivity tables for practical engineering calculations, and the values of the cross sections of absolute collisions «atom-atom» $\sigma_{11}^2 \Omega_{11}^{(2,2)*}$ and relative collisions «atom-molecule» β_{12}^2 for research.

The calculated values of the coefficients of viscosity and thermal conductivity are given in the table 15 ... 25, Figures 13-16 (where η_1 and λ_1 – viscosity and thermal conductivity of the monoatomic vapor; η_s and λ_s – viscosity and thermal conductivity at the saturation line; λ'_s – components of thermal conductivity at the saturation line; λ_f – «frozen» component of thermal conductivity; λ_r – conductive component; x_2 – mole fraction of molecules; P_s – vapor pressure at the saturation line).

Table 15

Viscosity of cesium in the gas phase $\eta \cdot 10^7, \text{Pa} \cdot \text{s}$

T, K	η_1	P, kPa									η_s
		1	10	25	50	100	400	600	1000	1500	
700	215,6	215,7									203,6
750	228,4	226,6	212,6								212,4
800	241,2	240,0	230,2								220,6
850	254,0	253,2	246,1	236,0							228,4
900	266,8	266,2	261,0	253,1	242,1						235,9
950	279,6	279,1	275,2	269,0	260,0	245,4					243,1
1000	292,4	292,0	288,9	284,1	276,7	264,1					250,2
1050	305,2	304,9	302,4	298,5	292,4	281,7					257,2
1100	318,0	317,8	315,8	312,5	307,4	298,3					264,1
1150	330,8	330,6	329,0	326,3	322,0	314,1	279,8				271,0
1200	343,6	343,4	342,0	339,8	336,1	329,3	298,1	283,5			277,9
1250	356,4	356,3	355,1	353,1	350,0	344,1	315,8	301,8			284,9
1300	369,2	369,1	368,1	366,4	363,7	358,4	332,8	319,6	299,2		291,9

(End of Table 15)

T, K	η_1	P, kPa									η_s
		1	10	25	50	100	400	600	1000	1500	
1350	382,0	381,9	381,0	379,5	377,2	372,6	349,3	336,9	317,2		299,0
1400	394,8	394,7	393,9	392,6	390,5	386,4	365,3	353,7	334,8	316,7	306,2
1450	407,6	407,5	406,8	405,7	403,8	400,1	380,9	370,1	352,0	334,3	313,6
1500	420,4	420,3	419,7	418,7	417,0	413,7	396,1	386,0	368,9	351,7	321,1
1550	433,2	433,1	432,6	431,7	430,1	427,2	411,0	401,6	385,3	368,7	328,6
1600	446,0	445,9	445,4	444,6	443,2	440,5	425,6	416,8	401,4	385,4	336,4
1650	458,8	468,7	458,3	457,5	456,3	453,8	440,1	431,8	417,3	401,8	344,2
1700	471,6	471,6	471,1	470,4	469,3	467,0	454,3	446,6	432,8	417,9	352,2
1750	484,4	484,4	484,0	483,3	482,3	480,2	468,4	461,2	448,1	433,8	360,3
1800	497,2	497,2	496,8	496,6	495,2	493,3	482,3	475,5	463,1	449,5	368,5
1850	510,0	510,0	509,6	509,1	508,2	506,4	496,1	489,7	478,0	464,9	376,7
1900	522,8	522,8	522,5	521,9	521,1	519,4	509,8	503,8	492,6	480,1	384,9
1950	535,6	536,6	535,3	534,8	534,0	532,4	523,4	517,7	507,1	495,1	–
2000	548,4	548,4	548,1	547,7	546,9	545,4	536,9	531,5	521,5	510,0	–

Table 16

Thermal conductivity of cesium in the gas phase $\lambda \cdot 10^4$, W/(m · K)

T, K	λ_1	P, kPa									λ_s
		1	10	25	50	100	400	600	1000	1500	
700	50,6	53,7									62,9
750	53,6	55,3	67,2								67,4
800	56,6	57,5	64,9								71,5
850	59,6	60,2	64,8	70,9							75,3
900	62,6	63,0	65,9	70,2	75,7						78,6
950	65,6	65,8	67,8	70,7	74,8	80,8					81,6
1000	68,6	68,8	70,1	72,2	75,1	79,8					84,4
1050	71,6	71,7	72,6	74,1	76,3	79,9					86,9
1100	74,6	74,7	75,3	76,4	78,0	80,8					89,2
1150	77,6	77,7	78,1	78,9	80,1	82,2	89,8				91,3
1200	80,6	80,6	81,0	81,6	82,5	84,1	90,3	92,6			93,4
1250	83,6	83,6	83,9	84,3	85,0	86,2	91,3	93,3			95,3
1300	86,6	86,6	86,8	87,1	87,7	88,6	92,7	94,5	96,6		97,2
1350	89,6	89,6	89,8	90,0	90,4	91,2	94,5	95,9	97,8		99,1
1400	92,6	92,6	92,7	92,9	93,2	93,8	96,5	97,7	99,3	100,4	100,9

(End of Table 16)

T, K	λ_1	P, kPa									λ_s
		1	10	25	50	100	400	600	1000	1500	
1450	95,6	95,6	96,7	95,8	96,1	96,5	98,6	99,6	101,0	102,0	102,7
1500	98,6	98,6	98,7	98,8	99,0	99,3	101,0	101,8	102,9	103,8	104,6
1550	101,6	101,6	101,7	101,7	101,9	102,2	103,5	104,1	105,1	105,7	106,5
1600	104,6	104,6	104,6	104,7	104,8	105,0	106,1	106,6	107,3	107,9	108,4
1650	107,6	107,6	107,6	107,7	107,8	107,9	108,7	109,1	109,7	110,1	110,4
1700	110,6	110,6	110,6	110,7	110,7	110,8	111,4	111,7	112,2	112,5	112,4
1750	113,6	113,6	113,6	113,6	113,7	113,8	114,2	114,4	114,7	114,9	114,3
1800	116,6	116,6	116,6	116,6	116,7	116,7	117,0	117,2	117,4	117,5	116,3
1850	119,6	119,6	119,6	119,6	119,6	119,7	119,9	120,0	120,1	120,1	118,7
1900	122,6	122,6	122,6	122,6	122,6	122,6	122,8	122,8	122,8	122,8	121,1
1950	125,6	125,6	125,6	125,6	125,6	125,6	125,7	125,7	125,6	125,6	–
2000	128,6	128,6	128,6	128,6	128,6	128,6	128,6	128,5	128,5	128,3	–

Table 17

The reaction component of the thermal conductivity C_s in the gas phase $\lambda_r \cdot 10^4$, W/(m · K)

T, K	λ_1	P, kPa									λ'_{p_s}
		1	10	25	50	100	400	600	1000	1500	
700	50,6	3,7	17,1								14,9
750	53,6	2,1	10,8								17,3
800	56,6	1,2	7,0								19,5
850	59,6	0,8	4,7	15,4							21,3
900	62,6	0,5	3,2	10,7	18,6						22,6
950	65,6	0,3	2,3	7,6	13,7	22,7					24,0
1000	68,6	0,2	1,7	5,5	10,2	17,6					25,0
1050	71,6	0,2	1,3	4,1	7,7	13,7					25,8
1100	74,6	0,1	1,0	3,1	5,9	10,8					26,4
1150	77,6	0,1	0,8	2,4	4,6	8,6	23,6				26,8
1200	80,6	0,1	0,6	1,9	3,7	6,9	20,1	25,4			27,1
1250	83,6	0,1	0,5	1,8	2,9	5,6	17,2	22,2			27,4
1300	86,6	0,1	0,4	1,2	2,4	4,6	14,7	19,3	25,6		27,6
1350	89,6	0,0	0,3	1,0	2,0	3,8	12,7	16,9	23,0		27,6
1400	92,6	0,0	0,3	0,8	1,7	3,2	10,9	14,8	20,6	26,3	27,7
1450	95,6	0,0	0,2	0,7	1,4	2,7	9,5	13,0	18,4	23,1	27,7

(End of Table 17)

T, K	λ_1	P, kPa									λ'_{ps}
		1	10	25	50	100	400	600	1000	1500	
1500	98,6	0,0	0,2	0,6	1,2	2,4	8,3	11,5	16,5	21,1	27,6
1550	101,6	0,0	0,2	0,5	1,0	2,0	7,3	10,2	14,9	19,2	27,6
1600	104,6	0,0	0,2	0,5	0,9	1,8	6,4	9,0	13,4	17,6	27,5
1650	107,6	0,0	0,1	0,4	0,8	1,6	5,7	8,1	12,1	16,0	27,4
1700	110,6	0,0	0,1	0,3	0,7	1,4	5,1	7,2	10,9	14,6	27,3
1750	113,6	0,0	0,1	0,3	0,6	1,2	4,5	6,5	9,9	13,4	27,2
1800	116,6	0,0	0,1	0,3	0,5	1,1	4,1	5,8	9,0	12,3	27,1
1850	119,6	0,0	0,1	0,2	0,5	1,0	3,7	5,3	8,2	11,3	26,1
1900	122,6	0,0	0,1	0,2	0,4	0,9	3,3	4,8	7,5	10,4	26,0
1950	125,6	0,0	0,1	0,2	0,4	0,8	3,0	4,4	6,9	9,6	–
2000	128,6	0,0	0,1	0,2	0,4	0,7	2,7	4,0	6,3	8,8	–

Table 18

«Frozen» component of the thermal conductivity Cs in the gas phase $\lambda_f \cdot 10^4$, W/(m · K)

T, K	λ_1	P, kPa									λ'_{fs}
		1	10	25	50	100	400	600	1000	1500	
700	50,6	49,9									47,9
750	53,6	53,2	50,1								50,1
800	56,6	56,3	54,1								52,1
850	59,6	59,4	57,8	55,6							54,0
900	62,6	62,5	61,3	59,5	57,1						55,8
950	65,6	65,5	64,6	63,2	61,1	58,1					57,5
1000	68,6	68,5	67,8	66,7	65,0	62,2					59,4
1050	71,6	71,5	70,9	70,0	68,6	66,2					61,1
1100	74,6	74,5	74,1	73,3	72,1	70,0					62,8
1150	77,6	77,5	77,2	76,5	75,5	73,6	66,2				64,5
1200	80,6	80,5	80,2	79,7	78,8	77,2	70,2	67,2			66,2
1250	83,6	83,6	83,3	82,8	82,1	80,6	74,1	71,2			67,9
1300	86,6	86,6	86,3	85,9	85,3	84,0	78,0	75,1	71,0		69,7
1350	89,6	89,6	89,4	89,0	88,4	87,3	81,8	79,0	74,8		71,4
1400	92,6	92,6	92,4	92,1	91,6	90,6	85,5	82,9	78,7	75,1	73,2
1450	95,6	95,6	95,4	95,1	94,7	93,8	89,1	86,6	82,6	78,9	75,1
1500	98,6	98,6	98,4	98,2	97,8	97,0	92,7	90,3	86,4	82,7	77,0
1550	101,6	101,6	101,4	101,2	100,8	100,1	96,2	94,0	90,2	86,5	78,9

(End of Table 18)

T, K	λ_1	P, kPa									λ'_{fs}
		1	10	25	50	100	400	600	1000	1500	
1600	104,6	104,6	104,5	104,3	103,9	103,3	99,6	97,5	93,9	90,3	80,9
1650	107,6	107,6	107,5	107,3	107,0	106,4	103,0	101,1	97,6	94,1	83,0
1700	110,6	110,6	110,5	110,3	110,0	109,5	106,4	104,5	101,3	97,9	85,1
1750	113,6	113,6	113,5	113,3	113,1	112,6	109,7	107,9	104,8	101,5	87,1
1800	116,6	116,6	116,5	116,4	116,1	115,6	113,0	111,3	108,4	105,2	89,3
1850	119,6	119,6	119,5	119,4	119,2	118,7	116,2	114,7	111,9	108,8	91,8
1900	122,6	122,6	122,5	122,4	122,2	121,8	119,4	118,0	115,4	112,4	94,4
1950	125,6	125,6	125,5	125,4	125,2	124,8	122,6	121,3	118,8	116,0	–
2000	128,6	128,6	128,5	128,4	128,2	127,9	125,8	124,5	122,2	119,5	–

Table 19

Molar fraction of the diatomic vapor molecules Cs X₂, %

T, K	P, kPa									At saturation curve	
	1	10	25	50	100	400	600	1000	1500	X ₂	P _s , kPa
700	0,775									3,33	4,524
750	0,456	4,22								4,29	10,15
800	0,286	2,72								5,31	20,59
850	0,130	1,82	4,33							6,36	36,34
900	0,163	1,27	3,06	5,78						7,43	66,56
950	0,093	0,92	2,23	4,27	7,91					8,50	1,090·10 ²
1000	0,069	0,68	1,66	3,22	6,07					9,56	1,696·10 ²
1050	0,052	0,52	1,27	2,48	4,74					10,58	2,536·10 ²
1100	0,040	0,40	0,99	1,95	3,75					11,57	3,649·10 ²
1150	0,032	0,32	0,79	1,56	3,02	10,33				12,51	5,687·10 ²
1200	0,026	0,26	0,64	1,26	2,46	8,65	12,03			13,40	6,896·10 ²
1250	0,021	0,21	0,52	1,04	2,04	7,29	10,25			14,23	9,119·10 ²
1300	0,018	0,18	0,44	0,87	1,70	6,20	8,79	13,26		15,01	1,180·10 ³
1350	0,015	0,15	0,37	0,73	1,44	5,31	7,59	11,58		15,73	1,496·10 ³
1400	0,013	0,13	0,31	0,62	1,23	4,68	6,59	10,16	13,97	16,39	1,864·10 ³
1450	0,011	0,11	0,27	0,53	1,06	3,98	5,75	8,95	12,42	16,99	2,285·10 ³
1500	0,009	0,09	0,23	0,46	0,92	3,48	5,05	7,92	11,08	17,54	2,760·10 ³
1550	0,008	0,08	0,20	0,40	0,80	3,07	4,47	7,05	9,93	18,04	3,291·10 ³
1600	0,007	0,07	0,18	0,36	0,71	2,71	3,97	6,30	8,92	18,47	3,877·10 ³
1650	0,006	0,06	0,16	0,32	0,63	2,42	3,54	5,68	8,04	18,87	4,519·10 ³

(End of Table 19)

T, K	P, kPa									At saturation curve	
	1	10	25	50	100	400	600	1000	1500	X_2	P_s , kPa
1700	0,006	0,06	0,14	0,28	0,56	2,16	3,18	5,09	7,28	19,21	$5,215 \cdot 10^3$
1750	0,005	0,05	0,13	0,25	0,50	1,94	2,86	4,60	6,61	19,52	$5,967 \cdot 10^3$
1800	0,005	0,05	0,11	0,23	0,48	1,78	2,59	4,17	6,02	19,80	$6,776 \cdot 10^3$
1850	0,004	0,04	0,10	0,20	0,41	1,69	2,36	3,80	5,50	20,06	$7,644 \cdot 10^3$
1900	0,004	0,04	0,09	0,19	0,37	1,45	2,14	3,47	5,04	20,31	$8,577 \cdot 10^3$
1950	0,003	0,03	0,08	0,17	0,34	1,32	1,96	3,19	4,64	–	–
2000	0,003	0,03	0,08	0,15	0,31	1,21	1,80	2,93	4,27	–	–

Table 20

Viscosity of rubidium in the gas phase $\eta \cdot 10^7$, Pa · s

T, K	η_l	P, kPa									η_s
		1	10	25	50	100	400	600	1000	1500	
700	198,5	194,2									186,2
750	210,1	207,6									193,7
800	221,8	220,2	207,4								200,8
850	233,4	232,4	223,4	211,1							207,4
900	245,1	244,3	237,9	228,5	215,8						213,9
950	256,7	256,2	251,4	244,2	233,8						220,1
1000	268,4	268,0	264,3	258,7	250,3	236,5					226,2
1050	280,0	279,7	276,9	272,4	265,6	253,8					232,2
1100	291,7	291,4	289,2	285,6	280,0	270,0					238,2
1150	303,3	303,1	301,3	298,4	293,7	283,3	249,8				244,2
1200	315,0	314,8	313,3	310,9	307,0	299,8	267,7	253,0			250,2
1250	326,6	326,5	325,3	323,2	319,9	313,7	284,8	270,8			256,3
1300	338,3	338,2	337,1	335,4	332,6	327,2	301,2	288,0	267,9		262,4
1350	349,9	349,8	348,9	347,4	345,0	340,4	317,0	304,6	285,3		268,6
1400	361,6	361,5	360,7	359,4	357,3	353,2	332,2	320,7	302,2	284,6	274,8
1450	373,2	373,2	372,5	371,3	369,5	365,9	346,9	336,3	318,7	301,5	281,1
1500	384,9	384,8	384,2	383,2	381,6	378,4	361,2	351,3	334,7	318,1	287,6
1550	396,5	396,5	395,9	395,1	393,6	390,7	375,1	366,0	350,3	334,3	294,1
1600	408,2	408,1	407,7	406,9	405,5	403,0	388,7	380,3	365,6	350,2	300,8
1650	419,8	419,8	419,4	418,6	417,5	415,1	402,1	394,3	380,4	365,7	307,5
1700	431,5	431,5	431,1	430,4	429,3	427,2	415,3	408,0	395,0	380,9	314,5

(End of Table 20)

T, K	η_1	P, kPa									η_s
		1	10	25	50	100	400	600	1000	1500	
1750	443,1	443,1	442,8	442,2	441,2	439,2	428,2	421,5	409,3	395,9	321,5
1800	454,8	454,8	454,4	453,9	453,0	451,2	441,0	434,8	423,3	410,5	328,7
1850	466,4	466,4	466,1	465,6	464,8	463,1	453,7	447,9	437,0	424,9	336,1
1900	478,1	478,1	477,8	477,3	476,6	475,0	466,3	460,8	450,6	439,1	343,7
1950	489,7	489,7	489,5	489,0	488,3	486,9	478,8	473,6	464,0	453,1	-
2000	501,4	501,4	501,1	500,7	500,1	498,8	491,1	486,3	477,2	466,8	-

Table 21

Thermal conductivity of Rb in the gas phase $\lambda \cdot 10^4$, W/(m · K)

T, K	λ_1	P, kPa									λ_s
		1	10	25	50	100	400	600	1000	1500	
700	72,4	79,9									93,4
750	76,7	80,5									100,2
800	80,9	83,0	98,8								106,4
850	85,1	86,4	96,1	108,4							111,9
900	89,4	90,1	96,3	104,7	115,2						116,7
950	93,6	94,1	98,1	103,9	111,7						121,0
1000	97,9	98,2	100,9	104,9	110,5	119,1					124,8
1050	102,1	102,4	104,2	107,0	111,1	117,7					128,3
1100	106,4	106,5	107,8	109,8	112,8	117,9					131,4
1150	110,6	110,8	111,6	113,1	115,3	119,1	132,6				134,3
1200	114,9	115,0	115,6	116,7	118,3	121,2	132,3	136,3			137,0
1250	119,1	119,2	119,7	120,4	121,7	123,9	132,9	136,5			139,5
1300	123,4	123,4	123,8	124,4	125,3	127,0	134,3	137,4	141,2		142,0
1350	127,6	127,7	127,9	128,4	129,1	130,4	136,3	139,0	142,4		144,7
1400	131,9	131,9	132,1	132,5	133,0	134,0	138,8	141,0	144,0	146,1	147,1
1450	136,1	136,2	136,3	136,6	137,0	137,8	141,5	143,3	145,8	147,7	149,2
1500	140,4	140,4	140,5	140,7	141,0	141,6	144,5	146,0	148,1	149,7	151,5
1550	144,6	144,7	144,7	144,9	145,1	145,6	147,9	149,0	150,7	152,1	153,8
1600	148,9	148,9	149,0	149,1	149,3	149,6	151,4	152,3	153,7	154,8	156,2
1650	153,1	153,2	153,2	153,3	153,4	153,7	155,1	155,8	156,9	157,8	158,7
1700	157,4	157,4	157,4	157,5	157,6	157,8	158,8	159,4	160,2	160,9	161,2
1750	161,6	161,7	161,7	161,7	161,8	161,9	162,7	163,1	163,7	164,2	163,7
1800	165,9	165,9	165,9	166,0	166,0	166,1	166,7	166,9	167,4	167,7	166,3

(End of Table 21)

T, K	λ_1	P, kPa									λ_s
		1	10	25	50	100	400	600	1000	1500	
1850	170,1	170,2	170,2	170,2	170,2	170,3	170,7	170,9	171,1	171,3	169,1
1900	174,4	174,4	174,4	174,4	174,4	174,5	174,7	174,8	175,0	175,0	171,9
1950	178,6	178,7	178,7	178,7	178,7	178,7	178,8	178,8	178,9	178,8	-
2000	182,9	182,9	182,9	182,9	182,9	182,9	182,9	182,9	182,8	182,7	-

Table 22

Reaction component of the steam thermal conductivity Rb
 $\lambda_r \cdot 10^4, W/(m \cdot K)$

T, K	λ_1	P, kPa									λ'_s
		1	10	25	50	100	400	600	1000	1500	
700	72,4	9,1									25,3
750	76,7	4,8									29,3
800	80,9	2,7	23,0								32,6
850	85,1	1,6	14,6	31,1							35,7
900	89,4	1,0	9,5	21,3	36,0						38,1
950	93,6	0,7	6,4	14,8	26,2						40,0
1000	97,9	0,5	4,4	10,5	19,2	32,5					41,4
1050	102,1	0,3	3,2	7,6	14,2	25,0					42,5
1100	106,4	0,2	2,3	5,6	10,7	19,3					43,3
1150	110,6	0,2	1,8	4,3	8,2	15,1	40,6				43,9
1200	114,9	0,1	1,3	3,3	6,4	12,0	34,3	42,8			44,3
1250	119,1	0,1	1,1	2,6	5,0	9,6	29,0	37,1			44,5
1300	123,4	0,1	0,8	2,1	4,0	7,8	24,5	32,1	42,2		44,6
1350	127,6	0,1	0,7	1,7	3,3	6,4	20,9	27,9	37,6		44,9
1400	131,9	0,1	0,6	1,4	2,7	5,3	17,9	24,2	38,6	41,3	45,0
1450	136,1	0,0	0,5	1,1	2,3	4,4	15,3	20,9	29,7	37,2	44,7
1500	140,4	0,0	0,4	1,0	1,9	3,7	13,1	18,2	26,3	33,6	44,5
1550	144,6	0,0	0,3	0,8	1,6	3,2	11,4	15,9	23,4	30,3	44,3
1600	148,9	0,0	0,3	0,7	1,4	2,7	9,9	14,0	20,8	27,4	44,1
1650	153,1	0,0	0,2	0,6	1,2	2,4	8,7	12,4	18,6	24,6	44,0
1700	157,4	0,0	0,2	0,5	1,0	2,1	7,7	11,0	16,7	22,6	43,8
1750	161,6	0,0	0,2	0,5	0,9	1,8	6,8	9,8	15,0	20,4	43,6
1800	165,9	0,0	0,2	0,4	0,8	1,6	6,0	8,7	13,5	18,5	43,3
1850	170,1	0,0	0,1	0,4	0,7	1,4	5,4	7,8	12,2	16,9	43,1
1900	174,4	0,0	0,1	0,3	0,6	1,3	4,9	7,1	11,1	15,4	42,8
1950	178,6	0,0	0,1	0,3	0,6	1,1	4,4	6,4	10,1	14,1	-
2000	182,9	0,0	0,1	0,3	0,6	1,0	4,0	5,8	9,2	12,9	-

Table 23

«Frozen» component of the steam thermal conductivity of *Rb*
 $\lambda_f \cdot 10^4, \text{W}/(\text{m} \cdot \text{K})$

T, K	λ_1	P, kPa									λ'_{3s}	
		1	10	25	50	100	400	600	1000	1500		
700	72,4	70,9										68,1
750	76,7	75,7										70,9
800	80,9	80,3	75,8									73,6
850	85,1	84,8	81,5	77,3								76,1
900	89,4	89,1	86,8	83,6	79,2							78,6
950	93,6	93,4	91,7	89,1	85,5							81,0
1000	97,9	97,7	96,4	94,4	91,4	86,7						83,4
1050	102,1	102,0	101,0	99,3	96,9	92,7						85,7
1100	106,4	105,3	105,5	104,1	102,1	98,5						88,1
1150	110,6	110,6	109,9	108,8	107,1	104,0	92,0					90,4
1200	114,9	114,8	114,3	113,4	111,9	109,3	98,1	93,5				92,7
1250	119,1	119,1	118,6	117,9	116,6	114,3	104,0	99,4				95,0
1300	123,4	123,4	123,0	122,3	121,2	119,2	109,8	105,3	98,9			97,4
1350	127,6	127,6	127,3	126,7	125,8	124,0	115,4	111,1	104,5			99,7
1400	131,9	131,9	131,6	131,1	130,3	128,7	120,9	116,8	110,4	104,9		102,1
1450	136,1	136,1	135,9	135,4	134,7	133,3	126,2	122,3	116,1	110,5		104,6
1500	140,4	140,4	140,1	139,8	139,1	137,9	131,4	127,8	121,8	116,1		107,0
1550	144,6	144,6	144,4	144,1	143,6	142,4	136,5	133,1	127,4	121,8		109,5
1600	148,9	148,9	148,7	148,4	147,9	146,9	141,5	138,3	132,9	127,4		112,1
1650	153,1	153,1	153,0	152,7	152,2	151,3	146,3	143,4	136,3	132,9		114,7
1700	157,4	157,4	157,2	157,0	156,6	155,7	151,2	148,4	143,5	138,4		117,4
1750	161,6	161,6	161,5	161,3	160,9	160,1	155,9	153,4	148,8	143,6		120,2
1800	165,9	165,9	165,8	165,5	165,2	164,5	160,6	158,2	153,9	149,2		123,1
1850	170,1	170,1	170,0	169,8	169,5	168,9	165,3	163,0	158,9	154,4		126,0
1900	174,4	174,4	174,3	174,1	173,8	173,2	169,9	167,8	163,9	159,6		129,1
1950	178,6	178,6	178,5	178,4	178,1	177,6	174,4	172,5	168,5	164,7		-
2000	182,9	182,9	182,8	182,6	182,4	181,9	179,0	177,1	173,7	169,8		-

Table 24

Molar fraction of the diatomic vapor molecules of $Rb X_2$, %

T, K	P, kPa									At saturation curve	
	1	10	25	50	100	400	600	1000	1500	X_2	P_s , kPa
700	1,153									3,44	3,132
750	0,646									4,42	7,399
800	0,387	3,62								5,46	16,66
850	0,245	2,35	5,51							6,53	30,27
900	0,163	1,59	3,79	7,07						7,60	54,31
950	0,113	1,11	2,69	5,11						8,66	91,63
1000	0,081	0,80	1,95	3,76	7,03					9,70	1,463·10 ²
1050	0,060	0,59	1,46	2,83	5,38					10,70	2,235·10 ²
1100	0,045	0,45	1,11	2,18	4,18					11,67	3,284·10 ²
1150	0,035	0,35	0,87	1,70	3,30	11,14				12,58	4,666·10 ²
1200	0,028	0,28	0,69	1,36	2,64	9,20	12,74			13,45	6,436·10 ²
1250	0,022	0,22	0,55	1,10	2,15	7,65	10,73			14,26	8,651·10 ²
1300	0,018	0,18	0,45	0,90	1,77	6,42	9,08	13,65		15,03	1,137·10 ³
1350	0,015	0,15	0,38	0,75	1,47	5,42	7,74	11,79		15,74	1,463·10 ³
1400	0,013	0,13	0,32	0,63	1,24	4,62	6,64	10,23	14,06	16,40	1,849·10 ³
1450	0,011	0,11	0,27	0,53	1,05	3,96	5,73	8,91	12,37	17,01	2,298·10 ³
1500	0,009	0,09	0,23	0,45	0,90	3,43	4,97	7,80	10,93	17,56	2,816·10 ³
1550	0,008	0,08	0,20	0,39	0,78	2,98	4,36	6,87	9,69	18,08	3,400·10 ³
1600	0,007	0,07	0,17	0,34	0,68	2,61	3,82	6,07	8,62	18,54	4,057·10 ³
1650	0,006	0,06	0,15	0,30	0,60	2,30	3,38	5,40	7,70	18,95	4784·10 ³
1700	0,005	0,05	0,13	0,26	0,53	2,04	3,00	4,82	6,91	19,31	5,562·10 ³
1750	0,005	0,05	0,12	0,23	0,47	1,82	2,68	4,32	6,22	19,63	6,448·10 ³
1800	0,004	0,04	0,10	0,21	0,42	1,63	2,40	3,88	5,62	19,90	7,360·10 ³
1850	0,004	0,04	0,09	0,19	0,37	1,46	2,16	3,61	5,09	20,12	8,372·10 ³
1900	0,003	0,03	0,08	0,17	0,34	1,32	1,96	3,18	4,63	20,29	9,420·10 ³
1950	0,003	0,03	0,08	0,15	0,30	1,20	1,78	2,89	4,22	20,42	0,1051E+05
2000	0,003	0,03	0,07	0,14	0,28	1,09	1,62	2,64	3,86	20,50	0,1165E+05

The errors of the tabular values of the coefficients of the viscosity and thermal conductivity are (estimation of errors was carried out according to the method [56; 57]):

for cesium:

at $T \leq 1600\text{ K}$, $\eta_l = 3\%$, $\eta_s = 5\%$, $\lambda_l = 4\%$, $\lambda_s = 6\%$;

at $T \leq 1750\text{ K}$, $\eta_l = 4,5\%$, $\eta_s = 7\%$, $\lambda_l = 5\%$, $\lambda_s = 8\%$;

at $T > 1750\text{ K}$, $\eta_l = 5\%$, $\eta_s = 10\%$, $\lambda_l = 8\%$, $\lambda_s = 10\%$;

for rubidium:

at $T \leq 1600\text{ K}$, $\eta_l = 3,5\%$, $\eta_s = 5\%$, $\lambda_l = 4,5\%$, $\lambda_s = 6\%$;

at $T \leq 1750\text{ K}$, $\eta_l = 5\%$, $\eta_s = 7\%$, $\lambda_l = 5,5\%$, $\lambda_s = 8\%$;

at $T > 1750\text{ K}$, $\eta_l = 6\%$, $\eta_s = 10\%$, $\lambda_l = 7\%$, $\lambda_s = 10\%$.

In practice, the coefficients of the thermal conductivity and viscosity of the alkali metals in the gas phase can be conveniently calculated by the ratios [2]:

$$\eta(T, x_2) = \eta_l(T) \left(1 + \sum_{n=1}^m A_n x_2^n \right), \quad (87)$$

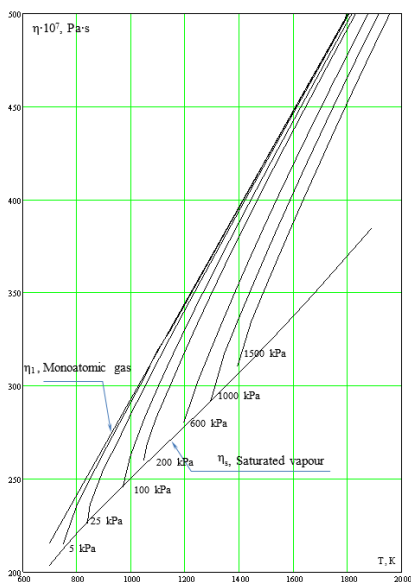

Figure 13. Viscosity of the cesium vapor

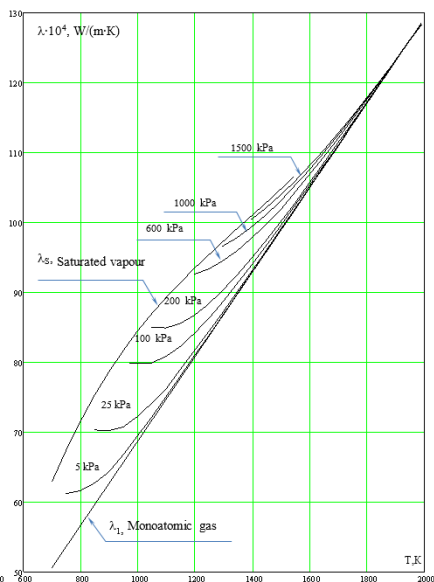

Figure 14. Thermal conductivity of the cesium vapor

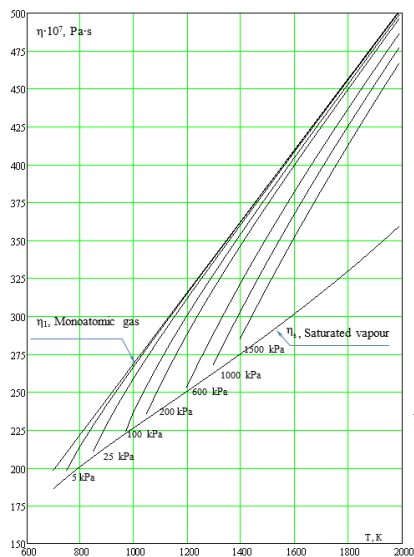

Figure 15. Viscosity of rubidium vapor

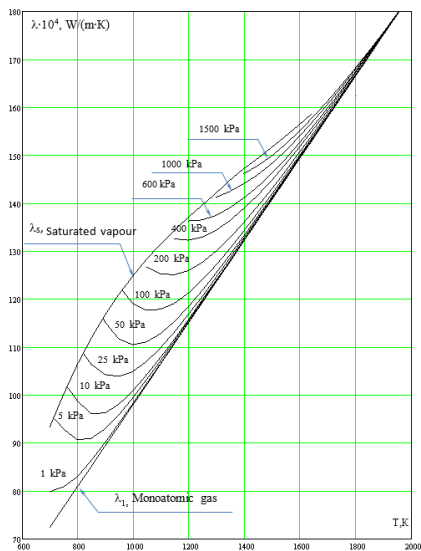

Figure 16. Thermal conductivity of the rubidium vapor

$$\lambda(T, x_2) = \lambda_1(T) \left(1 + \sum_{n=1}^m (B_n^{BH} + B_n^{II}) x_2^n + B_p (\Delta H / RT)^2 x_2 (1 - x_2) / (1 + x_2)^2 \right) \quad (88)$$

$$\lambda_{BH}(x_2, T) = \lambda_1(T) \sum_{n=1}^m B_n^{BH} x_2^n, \quad (89)$$

$$\lambda_{II}(x_2, T) = \lambda_1(T) \left(1 + \sum_{n=1}^m B_n^{II} x_2^n \right), \quad (90)$$

$$\lambda_3(x_2, T) = \lambda_1(T) \left(1 + \sum_{n=1}^m B_n x_2^n \right), \quad (91)$$

$$\lambda_3(x_2, T) = \lambda_1(T) \left(1 + \sum_{n=1}^m B_n x_2^n \right), \quad (92)$$

$$\lambda_p(x_2, T) = B_p \left(\frac{T_p}{T} \right)^2 \frac{x_2 (1 - x_2)}{(1 + x_2)^2}, \quad (93)$$

where x_2 – is the molar fraction of the diatomic molecules in the alkali metal vapor, ΔH – the thermal effect of the dissociation reaction of molecules at temperature T , coefficients: $A_n, B_n^{BH}, B_n^{II}, B_p$ are given in the table, they are determined by the relative collisions and thermodynamic constants of the alkali metal vapor, their numerical values are given in the table 25.

Table 25

Coefficients of equations (87-93)

n	1	2	3	1	2	3
Coefficient	Rubidium			Cesium		
A_n	-1.916	3.594	-6.615	-1.762	3.073	-5.256
B_n	-2.172	4.171	-7.903	-1.987	3.571	-6.316
B_n^n	-2.374	4.414	-8.195	-2.231	3.852	-6.640
B_n^{BH}	0.202	-0.243	0.292	0.244	-0.281	0.324
B_p	0.145	0.151				

The coefficients of the viscosity and thermal conductivity of cesium and rubidium in the gas phase on isobars are quite accurately approximated by polynomials of the third degree:

$$\eta \cdot 10^7 = \sum_0^3 c_n \tau^n, \quad Pa \cdot c, \quad (94)$$

$$\lambda \cdot 10^4 = \sum_0^3 b_n \tau^n, \quad \frac{Bm}{M \cdot K}, \quad (95)$$

where $\tau = \frac{T}{1000}$, $T = T^* \dots 2000K$.

The approximation error is less than 1%, which is much lower than the errors of the tabular values η and λ . The coefficients of equations (94, 95) are given in table 26.

Tables 18 and 23 show that the «frozen» component of the thermal conductivity λ_3 for cesium and rubidium vapor decreases with increasing concentration of molecules, and the «reaction» λ_p component increases (Tables 17, 22). Their total contribution depends on the magnitude β_{12}^2 and values the of thermodynamic constants. For steam Cs and Rb the maximum value, the pressure effect for thermal conductivity $(\lambda_s - \lambda_1) / \lambda_1 \approx 10 \div 30\%$

acquires at $T = 700...1300K$ (Tables 16, 21, Figures 14, 16, 17), so outside the specified temperature range, determining the relative cross sections of collisions β_{12}^2 from the experimental data on the thermal conductivity is associated with significant difficulties. The viscosity depending on the pressure (concentration of molecules) for the alkali metal vapor varies significantly over a wide range of temperatures. For $T = 800...2000K$ the effect of pressure for the vapor viscosity C_s and R_b is $(\eta_1 - \eta_s) / \eta_s \approx 10 \div 40\%$, therefore, in determining β_{12}^2 the preference should be given to the experimental data on the vapor viscosity of the alkali metals.

Table 26

Coefficients of equations (94, 95)

P, kPa	T°, K	a ₀	a ₁	a ₂	a ₃	b ₀	b ₁	b ₂	b ₃
1	2	3	4	5	6	7	8	9	10
Viscosity					Thermal conductivity				
Rubidium									
25	850	-157.5	593.6	-225.1	46.5	260.5	-401.6	314.5	-66.7
50	900	-233.6	717.1	-293.2	59.2	324.5	-508.5	373.4	-77.4
100	1000	-298.9	800.2	-327.5	63.5	325.7	-477.8	336.9	-66.9
200	1050	-380.6	891.4	-358.7	51.2	387.2	-562.5	374.2	-72.1
400	1150	-444.2	928.7	-353.2	61.4	421.0	-591.2	376.8	-70.4
1000	1300	-508.6	923.7	-317.7	51.2	442.7	-582.5	350.8	-62.9
P _s	700	64.0	223.8	-85.5	23.8	-60.9	337.1	-195.0	43.2
Cesium									
25	850	-114.7	536.5	-174.5	36.0	123.0	-163.7	143.9	-30.7
50	900	-180.0	641.3	-232.3	45.7	157.0	-219.5	174.1	-35.8
100	1000	-247.4	730.9	-271.6	52.2	193.0	-274.4	201.6	-40.3
200	1050	-341.2	861.4	-337.0	54.2	198.5	-264.1	185.1	-35.3
400	1150	-522.1	1139.9	-494.5	95.1	175.7	-198.1	133.5	-23.2
1000	1300	-257.6	501.8	-56.3	0.04	304.9	-417.7	260.5	-47.9
P _s	700	59.7	264.9	-103.1	28.4	-49.8	248.8	-149.2	34.5

6. Conclusions

The monograph is devoted to the experimental study of the viscosity of cesium and rubidium in the gas phase in unexplored regions of high temperatures, as well as the development of calculation equations and tables of transfer coefficients of these substances at temperatures up to 2000 K.

Main results of the work:

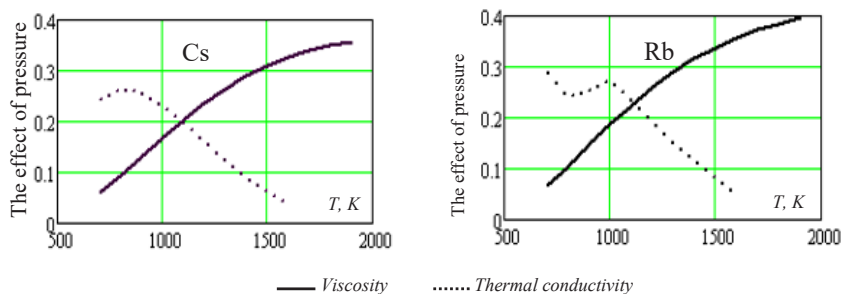

Figure 17. The effect of pressure in the pair of cesium and rubidium

An experimental installation for the study of the viscosity of the alkali metal vapor in a wide range of high (up to 2000 K) temperatures, implementing the method of a viscometer with an annular channel.

Have been developed high-temperature measuring cell, the design of which allows you to directly measure the temperature of the working element of the viscometer. This provides an accurate determination of the temperature of the investigated alkali metal vapor in the working gap.

The original method of stabilization of the steam generator operation mode was applied, which allowed to ensure the stationary flow of the investigated alkali metal vapor in the working element of the viscometer. Distinctive features of the created installation are high stability of modes of its work and considerable resource.

A large array of experimental data on the viscosity of the cesium vapor (167 points) and the rubidium vapor (61 points) at the following values of state parameters:

for cesium $T = 900 \dots 1770$ K, $P = 12 \dots 135$ kPa;

for rubidium $T = 990 \dots 1750$ K, $P = 39 \dots 135$ kPa.

Most of the obtained experimental data do not lie in the previously studied temperature range above 1200 K. The average error of the experimental data is 3%.

On the basis of the received experimental data dependences of the viscosity of steam of cesium and rubidium on temperature and structure (pressure) are established. The cross-sections of the «atom-atom» collisions and the relative cross-sections of the «atom-molecule» collisions are calculated.

Equations and tables of the viscosity and thermal conductivity of cesium and rubidium in the gas phase at $T = 700 \dots 2000$ K and $P = 1 \dots 1500$ kPa, including the saturation line were calculated. Obtained on the basis of experimental data [59; 61; 62; 65; 66; 69; 71; 72; 73; 74; 77; 80] on the viscosity of the rubidium and cesium vapor, the cross sections of the collisions agree well with the literature data, have high reliability and accuracy, so developed on their basis calculation equations and tables for the viscosity and thermal conductivity can be recommended for practical use in the scientific and engineering calculations by specialists in the field of research of properties of metals in the gas phase, creation of new types of the heat carriers and development of high-temperature power and technological equipment.

References:

1. Hirschfelder J., Curtiss C., Byrd R. (1961) *Molekulyarnaya teoriya gazov i zhidkostey* [Molecular theory of gases and liquids] / trans. with English. Moscow: Foreign. lit., 929 p.
2. Vargaftik N.B., Yarqin V.S. (1985) *Themat conductivity and viscosity of the gaseous phase. Handbook of Thermodynamic and Transport Properties of Alkali Metals*. Ed, R. Ohse. Oxford: Btchwett Scientific Publications, pp. 785–842.
3. Yargin B.C. (1982) *Issledovanie protsessov perenosa v dissotsirovannykh parakh shchelochnykh metallov* [Investigation of transfer processes in dissociated alkali metal vapors]: Dis. Dr. Tech. Sciences (specialty 01.04.14). Moscow: MAI, 288 p.
4. Shpilrain E.E., Yakimovich K.A., Totsky E.E. (1970) *Teplofizicheskie svoystva shchelochnykh metallov* [Thermophysical properties of alkali metals] / under ed. V.A. Kirillina. Moscow: Standartov Publishing House, 488 p.
5. Stepanenko I.F. etc. (1987) *Ustanovka dlya izmereniya vyzkostki parov shchelochnykh metallov pri vysokikh temperaturakh* [Installation for measuring the viscosity of alkali metal vapors at high temperatures]. *Measuring equipment*. no. 8, pp. 62–65.

6. Stepanenko I.F. (1988) *Ekspierimental'noe issledovanie i razrabotka tablits vyazkosti litiya i natriya v gazovoy faze* [Experimental study and development of lithium and sodium viscosity tables in the gas phase]: Diss. Cand. those. Science. Moscow: MAI, 127 p.

7. Bystrov P.I., Kagan D.N., Krechetov G.A., Spielrein E.E. (1988) *Zhidkometallicheskie teplonositeli teplovykh trub i energeticheskikh ustanovok* [Liquid metal heat carriers of heat pipes and power plants]. Moscow: Nauka, 263 p.

8. Dolgov V.I. (1983) *Ekspierimental'noe i teoreticheskoe issledovanie vyazkosti litiya v gazovoy faze* [Experimental and theoretical study of lithium viscosity in the gas phase]: Dis. Cand. physical mat. Science. Moscow: MAI, 250 p.

9. Greensburg B.I. (1986) *Sozdanie i issledovanie rubidii-gelievogo i kaliy-gelievogo kvantovykh magnitrometrov* [Development and research of rubidium-helium and potassium-helium quantum magnetrometers]: Abstract dis. Cand. physical and mathematical Science. Leningrad, 18 p.

10. Klyucharev A.I., Janson M.L. (1988) *Elementarnye protsessy v plazme shchelochnykh metallov* [Elementary processes in plasma of alkali metals]. Moscow: Energoatomizdat, 224 p.

11. Vargaftik N.B., Voljak L.D. (1985) Thermodynamic Properties of Alkali Metal Vapours at Low Pressures. Handbook of Thermodynamic and Transport Properties of Alkali Metals. Ed. R. Ohse. Oxford: Blackwell Scientific Publications, pp. 535–576.

12. Zarkova L.P., Stefanov B.I. (1965) Ekspierimental'noe opredelenie koefitsienta teploprovodnosti tsezievov plazm [Experimental determination of the thermal conductivity of cesium plasmas]. *International. symp. on properties and application of low-temperature plasma at XX International. congr. in theoretical and applied chemistry. Collection of reports*. Moscow, pp. 239–247.

13. Vinogradov Yu.K., Veryugin A.Z. (1978) Ekspierimental'noe issledovanie teploprovodnosti metodom periodicheskogo nagreva [Experimental study of thermal conductivity by periodic heating]. *Engineering Physics Journal*, no. 5, vol. 34. pp. 854–859.

14. Yargin B.C., Sidorov N.I., Studnikov E.L. (1978) *Vyazkost' i teploprovodnost' shchelochnykh metallov v gazovoy faze. Obzory po teplofizicheskim svoystvam veshchestv* [Viscosity and thermal conductivity of alkali metals in the gas phase. Reviews on the thermophysical properties of substances]. TFTS: IVTAN, 131 p.

15. Yargin B.C. (1975) Osobennosti protsessov perenosa v parakh shchelochnykh metallov [Features of transfer processes in alkali metal vapors]. *Sat. Thermophysical properties of working fluids and coolants of new technology*. Moscow: MAI, pp. 75–90.

16. Hirschfeldeir J.O. (1957) Heat Conductivity in Polyatomic or Etelectronicallu Excited Cases. II. *J. Chem. Phys.*, vol. 26, no. 2, pp. 282–285.

17. Stefanov B. (1980) Generalization of thermal conductivity and viscosity data for monatomic alkali metal vapours. High Temperatures-High Pressures, vol. 12, pp. 189–194.

18. Lee D.I., Bonilla C.F. Viscosity of the Atkali Metal Vapours. Part 1. Cesium up to 5 bars and 1000 °C. Alkali Metals Int. Symposium. Nottingham. 1966, Spec. Pub., no. 22, 1967, pp. 53–74.

19. Lee D.I., Bonilla C.F. (1968) The viscosity of the Alkali Metal Vapors. *Nucl. Eng. and Design*, no. 5, pp. 455–469.
20. Vargaftik N.B., Sidorov N.I., Tarlakov Yu.V. (1972) Eksperimental'noe issledovanie vyazkosti parov tseziya [Experimental study of the viscosity of cesium vapor]. *Thermophysics of high temperatures*, vol. 10, no. 6, pp. 1203–1209.
21. Tippetskirch H.V. (1976) Viscosities of Cesium Vapor to 1620 K and Liquid Gallium to 1800 K. *Berichte der Bunsengesellschaft für Physikalische Chemie*, B. 80, no. 8.
22. Henson R. M., Stratton T. E., Toood J. (1964) Viscosity of Cesium Vapor. *Bull. Am. Phys. Soc.* 3er 2. V. 9. P. 156.
23. Sidorov N.I. (1972) Eksperimental'noe issledovanie vyazkosti parov tseziya: Diss. kand. tehn. nauk. Moscow: MAI, 166 p.
24. Yargin V.S. (1978) Osobennosti teploprovodnosti schelochnykh metallov v gazovoy faze. Svyaz mezhdru teploprovodnostyu i vyazkostyu. *Inzhenerno-fizicheskiy zhurnal*, t. 34, no. 3, pp. 456–465.
25. Sidorov N.I., Tarlakov Yu.V., Yargin B.C. (1975) Rezultaty eksperimental'nogo issledovaniya vyazkosti parov rubidiya i tseziya. *Izvestiya vuzov. Ser. Energetika*. Moscow, pp. 96–101.
26. Grosse A.V. (1968) High-Temperature Properties of Cesium. *Inorganic Nuclear Chemical Letters*, V. 4, pp. 261–265.
27. Gottlieb M., Zollweg R.I. (1963) Thermal Conductivity of Cesium Vapor. In: *Advanced Energy Conversion*. Pergamon Press, V. 3, pp. 37–48.
28. Kitrilakis S., Meeker M. Experimental Determination of the Heat Conduction of Cesium Gas. I bid. P. 59–68.
29. Martini W.R. Theoretical Calculation of the Thermal Conductivity of Cesium Vapor at Thermoionic Temperatures. I bid. P. 49–58.
30. Zarkova L.P., Stefanov B.I. (1976) Izmerenie koeffitsienta teploprovodnosti gazov i parov do 2500 K. Pary rtuti i tseziya [Measuring the thermal conductivity of gases and vapors up to 2500 K. Vapors of mercury and cesium]. *Thermophysics of high temperatures*, vol. 14, no. 2, pp. 277–284.
31. Lee C.S., Bonilla C.F. (1967) Thermal Conductivity of the Alkali Metal Vapors and Argon. Proc. of the 7th Conference on Thermal Conductivity. NBS, USA, pp. 561–578.
32. Vargaftik N.B., Kerzhentsev V.V. (1973) Eksperimental'noe issledovanie koeffitsienta teploprovodnosti para tseziya [Experimental study of the thermal conductivity of cesium vapor]. *Thermophysics of high temperatures*, vol. 10, no. 1, pp. 59–65.
33. Timrot D.L., Makhrov Z.V., Sviridenko V.I., Reutov B.F. (1976) Eksperimental'noe issledovanie teploprovodnosti parov tseziya. [Experimental study of the thermal conductivity of cesium vapor]. *Thermophysics of high temperatures*, vol. 14, no. 1, pp. 67–74.
34. Vinogradov Yu.K. (1982) Eksperimental'noe izuchenie temperaturnoy zavisimosti teploprovodnosti parov tseziya [Experimental study of the temperature dependence of the thermal conductivity of cesium vapor], Moscow: MAI, 16 p. Dep. in VINITI, no. 5064-82.

34. Makhrov V.V. (1984) Razrabotka metodov issledovaniya, izmereniya teploprovodnosti perspektivnykh gazovykh teplonositeley s uchetom ikh akkomodatsii na tverдой poverkhnosti i sostavlenie tablits transportnykh svoystv [Development of research methods, measurement of thermal conductivity of promising gas coolants, taking into account their accommodation on a solid surface and compilation of tables of transport properties]: Dis. Dr. tech. Sciences, Moscow: MPEI, 462 p.

35. Vargaftik N.B., Studnikov E.L. (1972) *Eksperimental'noe issledovanie teploprovodnosti parov rubidiya* [Experimental study of the thermal conductivity of rubidium vapor]. *Thermal power engineering*, pp. 81–83.

36. Timrot D.L., Makhrov V.V., Reutov B.F. (1978) *Eksperimental'noe issledovanie teploprovodnosti parov rubidiya* [Experimental study of the thermal conductivity of rubidium vapor]. *Thermophysics of high temperatures*, vol. 16, no. 5, pp. 943–945.

37. Studnikov E.L. (1972) *Eksperimental'noe issledovanie teploprovodnosti parov rubidiya* [Experimental study of the thermal conductivity of rubidium vapor]: Diss. cand. those. Sciences. Moscow, 166 p.

38. Vinogradov Yu.K. (1990) *Razrabotka nestatsionarnykh metodov issledovaniya teploprovodnosti gazov i izmerenie teploprovodnosti perspektivnykh gazovykh teplonositeley* [Development of non-stationary methods for studying the thermal conductivity of gases and measuring the thermal conductivity of promising gas coolants]. Abstract of diss. dr. tech. Sciences (specialty 01.04.14). Moscow: MPEI, 34 p.

39. Radtsig A.A., Smirnov B.M. (1986) *Parametry atomov i atomnykh ionov: Spravochnik. 2-e izd.* [Parameters of atoms and atomic ions: a Handbook. 2nd ed.]. Moscow: Energoatomizdat, 344 p.

40. Arefiev K.M. (1983) *Yavleniya perenosa v gaze i plazme* [Transport phenomena in gas and plasma]. Moscow: Energoatomizdat, 112 p.

41. Eletsy A.V., Palkina L.A., Smirnov B.M. (1975) *Yavlenie perenosa v slaboionizirovannoy plazme* [Transport phenomenon in weakly ionized plasma]. Moscow: Atomizdat, 333 p.

42. Galitsky Z.M., Nikitin E.E., Smirnov B.M. (1981) *Teoriya stolknoveniy atomnykh chastits* [Theory of collisions of atomic particles]. Moscow: Nauka, 256 p.

43. Gurvich L.V., Veits I.V., Medvedev V.A. et al. (1982) *Termodinamicheskie svoystva individual'nykh veshchestv: Spravochnoe izdanie: v 4-kh t.* [Thermodynamic properties of individual substances: Reference book: in 4 volumes], 3rd ed. revised and expanded. v. 4, book 1. Moscow: Nauka, 623 p.

44. Vargaftik N.B. (1972) *Spravochnik po teplofizicheskim svoystvam gazov i zhidkostey. Izd. 2-e, dop. i pererab* [Reference book on thermophysical properties of gases and liquids]. Ed. 2nd, add. and reworked. Moscow: Nauka, 720 p.

45. Vargaftik N.B., Filippov L.P., Tarzimanov A.A., Totsky E.E. (1990) *Spravochnik po teploprovodnosti zhidkostey i gazov* [Handbook of thermal conductivity of liquids and gases]. Moscow: Energoatomizdat, 352 p.

46. Borzhievsky A.A. (1986) *Issledovanie elektroprovodnosti neideal'noy tsezievoy plazmy na podogrevaemoy adiabaticheskoy trube* [Investigation of the

electrical conductivity of a nonideal cesium plasma in a heated adiabatic tube]. Diss. cand. Phys.-Math. Sciences. Dolgoprudny: MIPT, 156 p.

47. Timrot D.L. (1985) Issledovanie teploprovodnosti i vyazkosti parov shchelochnykh metallov na kafedre inzhenernoy teplofiziki MEI [Investigation of thermal conductivity and viscosity of alkali metal vapors at the Department of Engineering Thermal Physics of MPEI]. *Thermophysical properties of working fluids, coolants and structural materials of modern energy. Interuniversity thematic collection no. 72*. Moscow: MPEI, pp. 3–17.

48. Stefanov B.I., Timrot D.L., Totsky E.E., Zhu Wen-hao (1966) Eksperimental'noe issledovanie vyazkosti i teploprovodnosti parov natriya i kaliya [Experimental study of the viscosity and thermal conductivity of sodium and potassium vapors]. *Thermophysics of high temperatures*, vol. 4, no. 1, pp. 141–142.

49. Makarov V.E. (1987) *Eksperimental'noe issledovanie vyazkosti i teploprovodnosti parov natriya i kaliya* [Experimental research and development of viscosity tables for potassium steam]: Abstract of the thesis. diss. cand. tech. Sciences (specialty 01.04.14). Moscow: MAI, 18 p.

50. Mozgovoy A.G., Roshchupkin V.V., Pokrasin M.A. etc. (1988) *Litii, natriy, kaliy, rubidiy, tseziy. Davlenie nasyshchennykh parov pri vysokikh temperaturakh* [Lithium, sodium, potassium, rubidium, cesium. Saturated vapor pressure at high temperatures]. USSR State Committee for Standards. Moscow: Publishing House of Standards, 38 p.

51. Idelchik I.E. (1975) *Spravochnik po gidravlicheskim soprotivleniyam* [Handbook of hydraulic resistance]. Moscow: Mashinostroenie, 559 p.

52. Aleshko P.I. (1977) *Mekhanika zhidkosti i gaza* [Mechanics of liquid and gas]. Kharkov: Vishcha shkola, 320 p.

53. *Dinamicheskaya vyazkost' i teploprovodnost' geliya, neona, argona, kriptona i ksenona pri atmosfernom davlenii v intervale temperatur ot normal'nykh tochek kipeniya do 2500 K. GSSSD 17-81* [Dynamic viscosity and thermal conductivity of helium, neon, argon, krypton and xenon at atmospheric pressure in the temperature range from normal boiling points to 2500 K. GSSSD 17-81] / USSR State Committee for Standards. Moscow: Publishing house. standards, 1982.

54. Taylor J. (1985) *Vvedenie v teoriyu oshibok* [Introduction to the theory of errors] / per. from English. Moscow: Mir, 272 p.

55. Selivanov M.N., Fridman A.E., Kudryashova Zh.F. (1987) *Kachestvo izmereniy. Metrologicheskaya spravochnaya kniga* [Measurement quality. Metrological reference book]. Leningrad: Lenizdat, 295 p.

56. Ryabinovich S.G. (1978) *Pogreshnosti izmereniy* [Measurement errors]. Leningrad: Energy, 261 p.

57. Kucheruk I.M., Andrianov V.M. (1981) *Obrobka rezul'tativ fizichnikh doslidzhen'* [Obrobka results in physical studies]. Kiev: Vishcha shkola, 216 p.

58. Dzis V.G., Stepanenko I.F., Yargin B.C. (1989) *Eksperimental'noe issledovanie vyazkosti i razrabotka tablits koeffitsientov perenosa tseziya v gazovoy faze. MAI* [Experimental study of viscosity and development of tables of cesium transfer coefficients in the gas phase. MAI]. Moscow, 23 p. Dep. in VINITI 29.03.89, no. 2275-B89.

59. Lukin V.I., Ivakin B.A., Sustin P.E. (1981) Eksperimental'noe issledovanie vyazkosti i razrabotka tablits koeffitsientov perenosa tseziya v gazovoy faze. MAI [Viscosity of some gases, measured by the unsteady flow method]. *Journal of Technical Physics*, vol. 51, no. 4, pp. 860–862.

60. Dzis V.G., Dyachinska O.M. (2020) V'yazkist' ta teploprovodnist' pari luzhnikh metaliv. Rubidiy. Tseziy [Viscosity and thermal conductivity of the steam of puddle metals. Rubid. Cesium]. *Sciences of Europe*, vol. 1, no. 51, pp. 16–29.

61. Dzis V.G., Nikolyuk P.K., Dyachinska O.M., Bubnovska I.A. (2007) V'yazkist' pari tseziyu pri visokikh temperaturakh [Viscosity of cesium vapor at high temperatures]. Actual Problems of Scientific Research – 2007: materials of the III – International Scientific and Practical Conference, volume 7. Dnepropetrovsk: Science and Education, pp. 49–51.

62. Shpil'rain E.E., Yakimovich K.A. e.a. (1985) Density and Thermal Expansion of Liquid Alkali Metals. *Handbook of Thermodynamic and Transport Properties of Alkali Metals*. Ed. R. Ohse. Oxford: Blackwell Scientific Publications, pp. 435–469.

63. GOST 3044-84 *Preobrazovateli termoelektricheskije. Nominal'nye staticheskie kharakteristiki preobrazovaniya* (1987) [Thermoelectric converters. Nominal static conversion characteristics]. Moscow: Publishing House of Standards, 78 p.

64. Dzis V.G., Stepanenko I.F., Sidorov N.I. and others (1988) *Eksperimental'noe issledovanie vyazkosti para tseziya pri temperaturakh 900-1250 K i davleniyakh 12-130 kPa* [Experimental study of the viscosity of cesium vapor at temperatures of 900-1250 K and pressures of 12-130 kPa]. Moscow: MAI, 12 p. Dep. in VINITI 26.03.88, no. 7576 – B88.

65. Dzis V.G., Stepanenko I.F., Yargin Z.S. (1989) *Rezul'taty eksperimental'nogo issledovaniya vyazkosti rubidiya v gazovoy faze pri vysokikh temperaturakh* [Results of an experimental study of the viscosity of rubidium in the gas phase at high temperatures]. Moscow; MAI, 7 p. Dep. in VINITI 28.12.83, no. 215 – B89.

66. Gill F., Murray W., Wright M. (1985) *Prakticheskaya optimizatsiya* / per. s angl [Practical optimization / translated from English]. Moscow: Mir, 509 p.

67. Vargaftik N.B., Yargin B.C., Sidorov N.I. and etc. (1984) *Koeffitsienty dinamicheskoy vyazkosti i teploprovodnosti v gazovoy faze* [Alkali metals. Coefficients of dynamic viscosity and thermal conductivity in the gas phase], GSSSD R72-84. Moscow: GSSSD, 56 p.

68. Dzis V.G. (1990) *Ekperimental'noe issledovanie vyazkosti i razrabotka tablits koeffitsientov perenosa tseziya i rubidiya v gazovoy faze* [Experimental study of viscosity and development of tables of transfer coefficients of cesium and rubidium in the gas phase]. Diss. cand. tech. Sciences (specialty 01.04.14). Moscow: MAI, 136 p.

69. Dzis V.G., Stepanenko I.F., Yargin V.S. (1989) *Rezul'taty eksperimental'nogo issledovaniya vyazkosti para tseziya metodom viskozimetra s kol'tsevym kanalom* [Results of an experimental study of the viscosity of cesium vapor by the method of a viscometer with an annular channel]. *Collection of scientific papers MPEI No. 204 "Issues of industrial technologies. Moscow energy institute*. Moscow, pp. 27–29.

70. Vinogradov Yu.K., Dzis V.G., Stepanenko I.F., Yargin V.S., Yakimovich Yu.K. (1989) Eksperimental'noe issledovanie protsessov perenosa shchelochnykh metallov v gazovoy faze pri temperaturakh 1200-2000 [Experimental study of transfer processes of alkali metals in the gas phase at temperatures of 1200-2000K]. *Thermophysical properties of substances. Proceedings of the VIII All-Union Conference. part 2*, Novosibirsk, pp. 144–148.

71. Dzis V.G., Stepanenko I.F., Yargin V.S. (1990) Eksperimental'noe issledovanie vyazkosti i razrabotka tablits koeffitsientov perenosa tseziya i rubidiya v gazovoy faze pri vysokikh temperaturakh [Experimental study of viscosity and development of tables of transfer coefficients for cesium and rubidium in the gas phase at high temperatures]. Dep. hands in VINITI No. 4206-90 dated 25.07.90.

72. Dzis V.G. (2020) Vyazkist i teploprovodnist pari tseziyu pri visokikh temperaturakh [Viscosity and thermal conductivity of cesium vapor at high temperatures]. *Slovak international scientific journal*, vol. 1, no. 40, pp. 31–34.

73. Vargaftik N.B., Vinogradov Yu.K., Dolgov V.I., Dzis V.G. and others (in all 7 authors) (1991) [Viscosity and thermal conductivity of alkali metals vapors at temperatures up to 2000 K]. *International Journal of Thermophysics*, vol. 12, no. 1, pp. 85–103.

74. Vinogradov Yu.K., Sidorov N.I., Yargin V.S. (1984) Teploprovodnost' i vyazkost' parov tseziya [Thermal conductivity and viscosity of cesium vapors]. *Engineering Physics Journal*, vol. 46, no. 5, pp. 863–875.

75. Vinogradov Yu. K. (1992) Rubidium dissociated vapour heat conductivity at temperatures up to 2000 K. *Teplofizika vysokikh temperature*, vol. 30, no. 1, pp. 63–68.

76. Dzis V.G. (1990) Jeksperimental'noe issledovanie v'язkosti i razrabotka tablits koeficientov perenosa cezija i rubidija v gazovoy faze [Experimental study of viscosity and development of tables for the transfer coefficients of cesium and rubidium in the gas phase]. Abstract dis. cand. tech. Sciences. Moscow: MAI, 20 p.

77. Dzis V.G., Stasenko V.A., Nikol'yuk P.K., Shnyorko V.M. (2002) V'язkist' ta teplo provodnist' tseziyu ta rubidiyu v gazoviy fazi pri visokikh temperaturakh [Viscosity and thermal conductivity of cesium and rubidium in the gas phase at high temperatures]. *Scientific notes of Vinnytsia State Pedagogical University named after M. Kotsyubynsky*. Vinnytsia: VSPU, Issue 1: Physics and Mathematics, pp. 466–473.

78. Dzis V.G., Nikol'yuk P.K., Bubnovska I.A., Dyachynska O.M. (2006) Koefitsienti perenosu pari rubidiyu [Rubidium bet transfer coefficient]. Conference «Actual Problems of Modern Sciences: Theory and Practice-2006» materials of the 3rd International Scientific and Practical. Dnipropetrovsk: Science and Education, vol. 22, pp. 49–52.

79. Dzis V.G., Dyachynska O.M. (2020) Eksperimental'ne doslidzhennya vyazkosti tseziyu i rubidiyu v gazoviy fazi [Experimental studies of the viscosity of cesium and rubidium in the gas phase]. *Danish Scientific Journal*, vol. 2, no. 37, pp. 37–51.

**APPLICATION EXAMPLES TO PROBLEMS
OF MODERN MATHEMATICAL APPARATUS**

Viktor Dubchak¹
Elvira Manzhos²

DOI: <https://doi.org/10.30525/978-9934-26-193-0-17>

Abstract. Purpose. The purpose of the research work is:

- possibility to combine different ways of solving certain mathematical problems. In general, the term “non-standard” methods of solving problems in mathematics has not defined yet, but many authors use this term in their researchers. It should be noted that there are many school problems that use unusual considerations. These are the tasks that are considered to be more complex and require non-standard methods of solving. These methods illustrate the wide possibilities of using well-acquired school knowledge and instill skills in using non-standard methods of reasoning in solving problems;
- the performance of comparative analysis in the calculations of spent work with different adjacent geometry of three-dimensional figures, which are given in this work;
- establishing a mathematical law for calculating the maximum number of embeddings of a set of homogeneous circular objects inside a certain external geometric structure.

Methodology. Research of this work is based on the use of modern mathematics, such as school and analytical geometry, the basics of integral calculus and their practical application, progression.

Practical implications. The first part of the paper presents several different methods for solving one geometric (stereometric) problem using both elementary geometry and higher mathematics, in particular, analytical geometry. These different ways of solving one specific problem demonstrate the versatility of the modern mathematical apparatus, link the mutual goals and methods of elementary and higher mathematics in specific applications. It is shown that the problem with the school formulation of the condition can

¹ Candidate of Technical Sciences, Associate Professor,
Vinnytsya National Agrarian University, Ukraine

² Candidate of Pedagogical Sciences,
National Pirogov Memorial Medical University, Ukraine

be solved by means of higher mathematics with the use of actions on vectors, the use of types of products of vectors and so on. The second part considers mathematical models of a specific technical problem based on the known law of physics, such as the calculation of some work under the action of gravity in a particular case. As such work, as it is established, is differentiated on a certain independent variable, therefore at first the value of a separate element of such work is established and integration of this element on this variable within its limits is executed. The given models with different geometry of the location of the three-dimensional body (reservoir, etc.), for which the study of this numerical characteristic is studied, are studied and compared, a comparative analysis is made in these two different positions of this body. The third part investigates the maximum filling of certain geometric both flat and three-dimensional external structures with many circular (spherical) figures, establishes a mathematical law for calculating the quantitative characteristics of such maximum filling, proposed and tested the criterion (coefficient) of efficiency and usefulness of such filling. For each of the parts of the given researches the corresponding figures, tables which supplement accordingly received results in the form of formulas and calculations are offered. Conclusions have been also made on the research conducted in the work.

Value/originality. The originality of the research is as follows:

- use and combination of school and higher mathematics in solving a specific geometric problem;
- the use of mathematical apparatus in calculating the work of solving a physical problem;
- establishment of the mathematical law of the maximum filling of a certain geometric structure by a homogeneous set of circular figures.

By solving one geometric problem in different methods or ways, it is possible to better understand the specific method, its advantages and disadvantages depending on the content of the problem. The use of different methods of such a solution provides an opportunity to replace it with another solution, which encourages to find alternative effective creative approaches to solving this problem.

It is not necessary to solve each problem in different ways or methods, just to choose one or two. In order to enhance cognitive activity and learn different methods of solving geometric problems, it is proposed to use non-standard methods of solving geometric problems.

Regarding the amount of work spent, the main element of novelty is the comparative analysis of such calculations in two related cases of the location of a geometric body (cylinder): when its foundations are vertical or horizontal.

The main element of the novelty of the results of the maximum filling of one geometric structure by a set of circular objects is the establishment of the mathematical law of quantitative characteristics of such filling, while proposing and testing a logical convenient coefficient of usefulness of such maximum filling.

1. Introduction

We can successfully translate the language spoken by nature into the language of mathematics and understand the structure of the relationships of any phenomenon. And once we formalize these connections, we can build certain mathematical models, predict the future states of the phenomena that these models describe, only on paper or inside computer memory. At the heart of modern mathematics are operations of counting, measuring and describing the shapes of the object under study. Translated from the ancient Greek, its name means “science”, “study”. This is the basis on which knowledge of structure, order and relations is based. They are the essence of science. Einstein, when asked where his lab was, smiled and pointed to a pencil and paper. Therefore, the role of mathematics is too important in human life, of course, this has not always been the case, people used to do without it, but modern man can not do without calculations of various types of complexity in today’s world.

Thus, the main purpose of the research of this work is the possibility and necessity of using a modern mathematical apparatus to solve specific mathematical technical or economic problems and to analyze the theoretical results of these studies. In mathematics, geometric problems play an important and multifaceted role. Solving such problems serves to achieve the goals set by the study of mathematics in both high school and higher education. Therefore, a lot of time in the study of mathematics is devoted to solving geometric problems. Such tasks allow to master the most important mathematical concepts, master mathematical symbolism, teach to perform proofs of various hypotheses, formulas, theorems and statements.

The purpose of the research work is to demonstrate:

- versatility of modern mathematical apparatus on the example of solving one specific mathematical problem;
- use of the known physical law of calculation of work in one applied problem in various variants of placement of a geometric working body;
- study of the maximum filling of certain geometric structures with many other homogeneous bodies (figures).

Mathematical problems of different directions can serve as a foundation for mastering new theoretical issues, consolidate acquired knowledge, illustrate the practical application of the studied material in new approaches in solving certain problems. Thus, the skills and abilities of a certain mental activity are formed, which is combined with such important traits of character as persistence, attentiveness, concentration. The well-known law of physics on the calculation of work under the action of gravity on a certain displacement has some application in another problem of the results of research data, which leads to the formation and calculation of the corresponding integral expressions. The question of the optimal maximum filling of certain external geometric structures with a homogeneous internal set of circular objects is also always an important and urgent task.

Review of recent research and publications. To study methods of proving and solving problems of a certain class, it is important to have algorithms, schemes and to understand the outlines of their applications [1]. The application of acquired mathematical knowledge must be found in solving standard and non-standard problems, to predict the results of certain studies. Therefore, at the beginning of solving the problem analyze certain ideas and methods, using illustrative tools, compare all ways of finding a solution to the problem and choose the most logical of them.

In geometry, it is important to form the need for proofs using a variety of methods and ways to solve such problems. When solving a certain problem in several ways or methods, the acquired skills are transferred to other conditions, repeated in new connections [2–3].

In many mathematics applications and the use of mathematical apparatus in solving physical or technical problems, the question of evaluation, calculation of work spent is an extremely important issue [3–6]. The solution of one of such problems in the given two adjacent cases is offered in this work.

The solution of the problem of maximum filling of certain external geometric structures with a homogeneous set of circular (spherical) objects is widely used in various spheres of human life [7–12]. Finding a quantitative characteristic of such a filling is given in these studies.

2. Several approaches to solving one geometric problem

Here is an example of one of these problems. It demonstrates methods to solve them.

Formulation of the problem is to determine the angle between the bisectors of two plane angles of a regular tetrahedron, which are drawn from one vertex.

Methods to solve the problem.

The first method.

By the definition of a regular tetrahedron [3], whichever face we consider, we have an equilateral triangle. Drop from the vertex D of the tetrahedron DABC bisectors DM and DN on the face ADC and ADB (Figure 1). We obtain the angle between the bisectors of two plane angles.

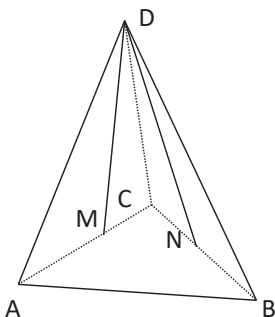

Figure 1. DABC tetrahedron with the desired angle between the apophemes DM and DN

Suppose $BC = x$, then $MN = \frac{1}{2}x$ (the middle line of the triangle ABC),
 $DN = DM = \frac{\sqrt{3}}{2}x$ (by the property of bisectors of equilateral triangles ADC, ADB) and $\angle NDM = \alpha$.

$\triangle NDM$ – isosceles, where – the height of the triangle and $\angle NDK = \frac{\alpha}{2}$ and $KN = \frac{1}{4}x$, by the definition $\sin \frac{\alpha}{2} = \frac{KN}{DN} = \frac{1}{2\sqrt{3}}$;

$$\cos \frac{\alpha}{2} = \frac{DK}{DN} = \frac{\sqrt{DN^2 - KN^2}}{DN} = \sqrt{\frac{11}{12}}.$$

Then, $\cos \alpha = \cos^2 \frac{\alpha}{2} - \sin^2 \frac{\alpha}{2} = \frac{11}{12} - \frac{1}{12} = \frac{5}{6}$, where $\alpha = \arccos \frac{5}{6}$.

It should be noted that $\cos \alpha$ can be found by the theorems of cosines and sines:

By the sine theorem: $\frac{DN}{\sin \angle DMN} = \frac{MN}{\sin \angle MDN}$, where $DN = \frac{\sqrt{3}}{2}x$, $\angle DMN = \angle DMK = 90^\circ - \frac{\alpha}{2}$, $MN = \frac{1}{2}x$.

$$\frac{\frac{\sqrt{3}}{2}x}{\sin(90 - \frac{\alpha}{2})} = \frac{\frac{1}{2}x}{\sin \alpha},$$

$$\frac{\sqrt{3}}{\cos \frac{\alpha}{2}} = \frac{1}{2 \sin \frac{\alpha}{2} \cos \frac{\alpha}{2}},$$

$$\sin \frac{\alpha}{2} = \frac{1}{2\sqrt{3}},$$

$$\cos \frac{\alpha}{2} = \frac{DK}{DN} = \frac{\sqrt{DN^2 - KN^2}}{DN} = \frac{\sqrt{\frac{3}{4}x^2 - \frac{1}{16}x^2}}{\frac{\sqrt{3}}{2}x} = \sqrt{\frac{11}{12}}$$

$\cos \alpha = \cos^2 \frac{\alpha}{2} - \sin^2 \frac{\alpha}{2} = \frac{11}{12} - \frac{1}{12} = \frac{5}{6}$, where $\alpha = \arccos \frac{5}{6}$.

By the cosine theorem:

$$MN^2 = DM^2 + DN^2 - 2DM \cdot DN \cos \angle MDN = 2DN^2 - 2DN^2 \cos \angle MDN$$

$$\frac{1}{4}x^2 = 2\frac{3}{4}x^2 - 2\frac{3}{4}x^2 \cos \alpha,$$

$$\cos \alpha = \frac{5}{6}, \text{ де } \alpha = \arccos \frac{5}{6}.$$

The second method. Place the correct tetrahedron DABC in the Cartesian coordinate system, so that the vertex D lies on the positive half-axis and is projected in the center of the base ΔABC , located in the XOY plane, ie at the p. (0; 0; 0) (Figure 2).

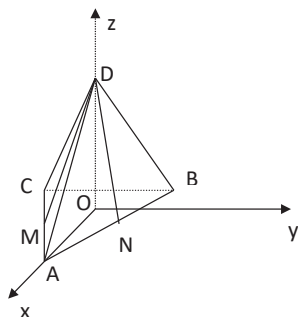

Figure 2. The given tetrahedron in three-dimensional space, the base center of which coincides with the origin.

Suppose p. A (1; 0; 0), then p. B (x1; y1; 0) and p. C (x2; y2; 0).

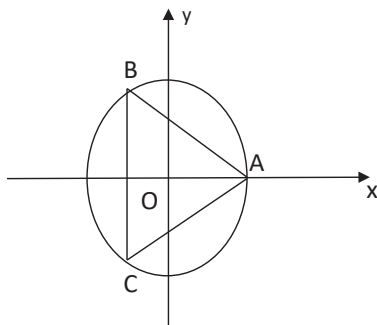

Figure 3. The base of the tetrahedron in the XOY plane, inscribed in a circle with the center at the origin

Describe around $\triangle ABC$ a unit circle and find the coordinates of points B and C with the definition of trigonometric functions (Figure 3).

$$x_1 = -\cos 60^\circ = -\frac{1}{2};$$

$$y_1 = \sin 60^\circ = \frac{\sqrt{3}}{2}; \quad \text{ie p. } B\left(-\frac{1}{2}; \frac{\sqrt{3}}{2}; 0\right).$$

$$x_2 = -\cos 60^\circ = -\frac{1}{2};$$

$$y_2 = -\sin 60^\circ = -\frac{\sqrt{3}}{2}; \quad \text{ie p. } C\left(-\frac{1}{2}; -\frac{\sqrt{3}}{2}; 0\right).$$

According to the formula for the distance between two points:

$$AB = \sqrt{\left(-\frac{1}{2}-1\right)^2 + \left(\frac{\sqrt{3}}{2}-0\right)^2 + (0-0)^2} = \sqrt{3}.$$

By placement in space p. $D(0; 0; z)$, тоді $\overline{AD} = \{-1; 0; z\}$, $|\overline{AD}| = \sqrt{1+z^2}$.

Since $AD = AB = \sqrt{3}$, then we get equality $\sqrt{1+z^2} = \sqrt{3}$; out of here $z_1 = \sqrt{2}$ and $z_2 = -\sqrt{2}$ (does not satisfy the condition of placement p. D).

Then p. $D(0; 0; \sqrt{2})$.

Draw from the vertex D of the bisector DM i DN flat corners $\angle ADC$ i $\angle ADB$ (Figure 2). By construction MN – midline $\triangle ABC$, ie p. $M(x_3; y_3; 0)$ – middle side AB, p. $N(x_4; y_4; 0)$ – middle side AC.

Find the coordinates of the points M i N :

$$x_3 = \frac{1 + \left(-\frac{1}{2}\right)}{2} = \frac{1}{4};$$

$$y_3 = \frac{0 + \frac{\sqrt{3}}{2}}{2} = \frac{\sqrt{3}}{4}; \quad \text{p. } M\left(\frac{1}{4}; \frac{\sqrt{3}}{4}; 0\right),$$

$$x_4 = \frac{1 + \left(-\frac{1}{2}\right)}{2} = \frac{1}{4};$$

$$y_4 = \frac{0 - \frac{\sqrt{3}}{2}}{2} = -\frac{\sqrt{3}}{4}; \quad \text{p. } N\left(\frac{1}{4}; -\frac{\sqrt{3}}{4}; 0\right).$$

$$\text{Then, } \overline{DM} = \left\{ \frac{1}{4}; \frac{\sqrt{3}}{4}; \sqrt{2} \right\}; \quad \overline{DN} = \left\{ \frac{1}{4}; -\frac{\sqrt{3}}{4}; \sqrt{2} \right\};$$

$$\cos \angle MDN = \frac{\overline{DM} \cdot \overline{DN}}{|\overline{DM}| \cdot |\overline{DN}|} = \frac{\frac{1}{4} \cdot \frac{1}{4} + \frac{\sqrt{3}}{4} \cdot \left(-\frac{\sqrt{3}}{4}\right) + \sqrt{2} \cdot \sqrt{2}}{\sqrt{\frac{1}{16} + \frac{3}{16} + 2} \cdot \sqrt{\frac{1}{16} + \frac{3}{16} + 2}} = \frac{5}{6},$$

where $\angle MDN = \arccos \frac{5}{6}$.

The third method.

Consider more general case of constructing a DABC tetrahedron with an arbitrary side a and arbitrary coordinates of its vertices.

Suppose p. A $(x_1; y_1; z_1)$ according to the coordinates of this point we will consistently construct the other three points, indicating their coordinates.

We set ΔABC in the XOY plane of the rectangular coordinate system. So, p. A $(x_1; y_1; 0)$, p. B $(x_2; y_2; 0)$, p. C $(x_3; y_3; 0)$.

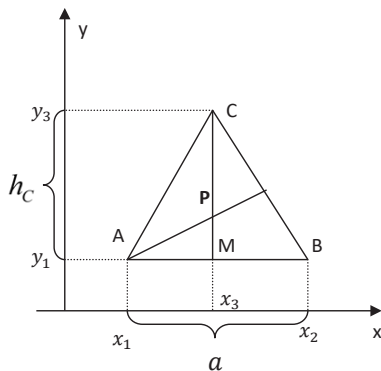

Figure 4. Projection of an arbitrary tetrahedron into the XOY plane (side AB parallel to the OX axis)

To simplify the calculations of the given model, let one of the sides (for example, the side AB) be parallel to one of the coordinate axes (for example, the OX axis) (Figure 4), then $\begin{cases} x_2 = x_1 + a \\ y_2 = y_1 \end{cases}$ p. B $(x_1 + a; y_1; 0)$.

Obviously, the coordinates of p. C ΔABC will be as follows:

$$\begin{cases} x_3 = \frac{x_1 + x_2}{2}; \\ y_3 = y_1 + h_c; \end{cases} \quad \text{т. C} \left(\frac{2x_1 + a}{2}; y_1 + \frac{a\sqrt{3}}{2}; 0 \right).$$

$$\begin{cases} x_3 = \frac{2x_1 + a}{2}; \\ y_3 = y_1 + \frac{a\sqrt{3}}{2}; \end{cases}$$

Suppose p. P is the point of intersection of the heights ΔABC , ie $CM = h_c = \frac{a\sqrt{3}}{2}$ on this $PM = \frac{1}{3}h_c = \frac{a\sqrt{3}}{6}$. Then, p. P $\left(\frac{2x_1 + a}{2}; y_1 + \frac{a\sqrt{3}}{6}; 0 \right)$.

In turn, the fourth vertex D of the DABC tetrahedron is projected in p. $P \Delta ABC$ and it will have the following coordinates: p. D $\left(\frac{2x_1 + a}{2}; y_1 + \frac{a\sqrt{3}}{6}; h_D \right)$,

where $h_D = DP$ – the height of the tetrahedron DABC, dropped from the vertex D to the face ΔABC .

With ΔDPB , we have: $BD^2 = BP^2 + PD^2$ or $|\overline{BD}|^2 = |\overline{BP}|^2 + |\overline{PD}|^2$, where $|\overline{PD}| = h_D$.

$$\overline{BP} = \left\{ \frac{2x_1 + a}{2}; \frac{a\sqrt{3}}{6}; 0 \right\}, \quad |\overline{BP}| = \sqrt{\frac{a^2}{4} + \frac{a^2}{12}} = \frac{a}{\sqrt{3}}.$$

$$\text{Then, } a^2 = \frac{a^2}{3} + h_D^2 \Rightarrow h_D = \frac{a\sqrt{2}}{\sqrt{3}}.$$

$$\text{Therefore, т. D} \left(\frac{2x_1 + a}{2}; y_1 + \frac{a\sqrt{3}}{6}; \frac{a\sqrt{2}}{\sqrt{3}} \right).$$

Finding successively all four vertices of the tetrahedron DABC, each edge of which is equal a , find the coordinates of the points M and N, which correspond to the bases of the apophemes DM and DN of the constructed tetrahedron:

$$x_M = \frac{x_B + x_C}{2} = \frac{4x_1 + 3a}{4}; \quad \text{p. M} \left(\frac{4x_1 + 3a}{4}; \frac{4y_1 + a\sqrt{3}}{4}; 0 \right).$$

$$y_M = \frac{y_B + y_C}{2} = \frac{4y_1 + a\sqrt{3}}{4};$$

$$x_N = \frac{x_B + x_A}{2} = \frac{2x_1 + a}{2}; \quad \text{p. N} \left(\frac{2x_1 + a}{2}; y_1; 0 \right).$$

$$y_N = \frac{y_B + y_A}{2} = y_1;$$

$$\text{Then, } \overline{DM} = \left\{ \frac{a}{4}; \frac{a\sqrt{3}}{12}; -\frac{a\sqrt{2}}{\sqrt{3}} \right\} \text{ and } \overline{DN} = \left\{ 0; -\frac{a\sqrt{3}}{6}; -\frac{a\sqrt{2}}{\sqrt{3}} \right\},$$

$$|\overline{DM}| = |\overline{DN}| = \sqrt{\frac{3a^2}{36} + \frac{2a^2}{3}} = \frac{\sqrt{3}a}{2};$$

$$\overline{DM} \cdot \overline{DN} = -\frac{a^2}{24} + \frac{2a^2}{3} = \frac{15}{24}a^2 \text{ (scalar product of vectors).}$$

$$\text{Therefore, } \cos \angle MDN = \frac{\overline{DM} \cdot \overline{DN}}{|\overline{DM}| \cdot |\overline{DN}|} = \frac{\frac{15}{24}a^2}{\left(\frac{\sqrt{3}a}{2} \right)^2} = \frac{5}{6}, \text{ where } \angle MDN = \arccos \frac{5}{6}.$$

The value of the trigonometric function of the required angle $\angle MDN$ can also be found using the vector product of some vectors. Since, for the area ΔDNM of the tetrahedron DABC the following relations are valid:

$$S_{\Delta DNM} = \frac{1}{2} |\overline{DM} \times \overline{DN}| = \frac{1}{2} |\overline{DM}| |\overline{DN}| \sin \angle (\overline{DM}; \overline{DN}), \text{ de } \overline{DM} \times \overline{DN} - \text{vector product of vectors, whence } \sin \angle (\overline{DM}; \overline{DN}) = \frac{|\overline{DM} \times \overline{DN}|}{|\overline{DM}| |\overline{DN}|}.$$

Whereas

$$|\overline{DM} \times \overline{DN}| = \begin{vmatrix} i & j & k \\ a & \frac{a\sqrt{3}}{12} & -\frac{a\sqrt{2}}{\sqrt{3}} \\ 0 & -\frac{a\sqrt{3}}{6} & -\frac{a\sqrt{2}}{\sqrt{3}} \end{vmatrix} = \left| -\frac{a^2\sqrt{2}}{4}i + \frac{a^2\sqrt{2}}{4\sqrt{3}}j - \frac{a^2\sqrt{3}}{24}k \right| = a^2 \sqrt{\frac{1}{8} + \frac{1}{24} + \frac{1}{192}} = \frac{a^2\sqrt{11}}{8}$$

and $|\overline{DM}| = |\overline{DN}| = \frac{\sqrt{3}a}{2}$, then

$$\sin \angle(\overline{DM}; \overline{DN}) = \frac{\frac{a^2 \sqrt{11}}{4}}{\frac{3a^2}{6}} = \frac{\sqrt{11}}{6} \Rightarrow \cos \angle(\overline{DM}; \overline{DN}) = \sqrt{1 - \sin^2 \angle(\overline{DM}; \overline{DN})} = \sqrt{1 - \frac{11}{36}} = \frac{5}{6},$$

$$\angle MDN = \arccos \frac{5}{6}.$$

The fourth method.

Consider the correct tetrahedron $DABC$ (Figure 5) and introduce the following notation: $\overline{AC} = \vec{a}$, $\overline{AB} = \vec{b}$, $\overline{AD} = \vec{c}$. It is known that $\angle(\vec{a}; \vec{b}) = \angle(\vec{a}; \vec{c}) = \angle(\vec{b}; \vec{c}) = 60^\circ$ and $|\vec{a}| = |\vec{b}| = |\vec{c}| = 1$.

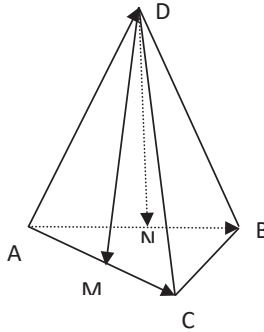

Figure 5. The given tetrahedron in vectors

By the property of vectors: $\overline{BC} = -\vec{b} + \vec{a}$ та $\overline{MN} = \frac{1}{2}\overline{BC} = \frac{1}{2}(\vec{a} - \vec{b})$;

$\overline{DN} = -\frac{\vec{b}}{2} + \vec{c}$; $\overline{DM} = -\frac{\vec{a}}{2} + \vec{c}$. Then, $\cos \angle(\overline{DM}; \overline{DN}) = \frac{\overline{DM} \cdot \overline{DN}}{|\overline{DM}| |\overline{DN}|}$, where

$$\begin{aligned} \overline{DN} \cdot \overline{DM} &= \left(\vec{c} - \frac{\vec{b}}{2}\right) \cdot \left(\vec{c} - \frac{\vec{a}}{2}\right) = |\vec{c}|^2 - \frac{1}{2}\vec{a} \cdot \vec{c} - \frac{1}{2}\vec{b} \cdot \vec{c} + \frac{1}{4}\vec{a} \cdot \vec{b} = 1 - \frac{1}{2}|\vec{a}||\vec{c}| \cos 60^\circ - \\ &- \frac{1}{2}|\vec{b}||\vec{c}| \cos 60^\circ + \frac{1}{4}|\vec{a}||\vec{b}| \cos 60^\circ = 1 - \frac{1}{4} - \frac{1}{4} + \frac{1}{8} = \frac{5}{8}; \end{aligned}$$

$$|\overline{DN}|^2 = |\overline{c}|^2 - \left|\frac{\overline{b}}{2}\right|^2 = 1 - \frac{1}{4} = \frac{3}{4} \Rightarrow |\overline{DN}| = |\overline{DM}| = \frac{\sqrt{3}}{2}.$$

$$\text{Therefore, } \cos \angle(\overline{DM}; \overline{DN}) = \frac{\overline{DM} \cdot \overline{DN}}{|\overline{DM}| \cdot |\overline{DN}|} = \frac{\frac{5}{8}}{\frac{3}{4} \cdot \frac{5}{6}} = \frac{5}{6}, \text{ where } \angle MDN = \arccos \frac{5}{6}.$$

Considering the methods of solving this problem, we understand how closely intertwined the variety of approaches to elementary and higher mathematics. Examples of some interesting methods and ways of solving a specific geometric problem that can be used in solving both standard and non-standard problems using both geometric and algebraic mathematical foundations are given. Such research provides an opportunity to expand mathematical knowledge, demonstrate that mathematics is a living and interesting science.

3. Calculation of work in one applied technical problem with different geometry of arrangement and comparison of the received results

There is a cylindrical tank with the appropriate geometric parameters: R -the radius of the circle of the base of this three-dimensional figure, H -its height. This container is filled with some liquid density ρ . The main task of these studies is comparative numerical characteristics of the pumping (raising to the surface of the tank) of the volume of this liquid in two cases: in the first – if the geometric structure has a horizontal arrangement of its bases (Figure 6), in the second – when such bases of the cylindrical structure will have a vertical position (Figure 7).

Research results. In determining the magnitude of such work in each of these cases the well-known physical law [4-6] should be used, according to which in the first case (Figure 6) to raise elementary mass of liquid mass to the surface of such a reservoir $\Delta m_1 \approx \pi \rho R^2 dy$, located at an arbitrary height y , the magnitude of the elementary work ΔA_1 is roughly defined as the product of the elementary force of gravity $\Delta F \approx g \Delta m$ to the appropriate lifting height equal to $(H - y)$, herewith $y \in [0; H]$, thus

$$\Delta A_1 \approx \pi \rho g R^2 (H - y) \Delta y.$$

As can be seen from the last formula, the value of the elementary work on raising the elementary volume of the liquid allotted at arbitrarily taken y

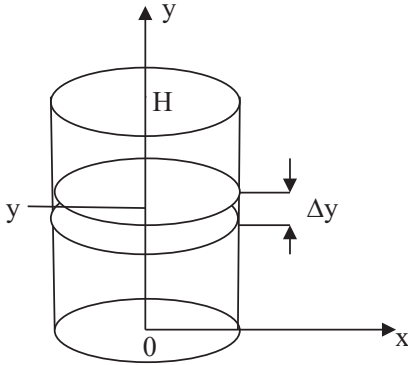

Figure 6. Cylindrical tank filled with liquid and horizontally arranged bases

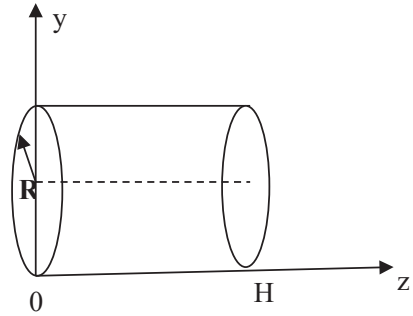

Figure 7. Cylindrical tank filled with liquid and vertically arranged bases

at the appropriate height for raising to the surface of the tank is the value of differentiated (variable) depending on the same ordinate.

If in this equation provided that Δy goes to zero, ΔA_1 will also go to zero, therefore, the corresponding increments of the argument and its dependent function can be replaced by differentials of these infinitesimal quantities, and the approximate equal sign can be replaced by an exact one, ie $dA_1 = \pi \rho g R^2 (H - y) dy$.

$$\text{Whereas } A_1 = \int_0^H dA_1(y),$$

then, having integrated the right-hand side of the last equality on the variable y within the possible change of this argument, replacing the approximate sign of equality with the exact one, we have the final result of the desired work A_1 :

$$A_1 = \int_0^H \pi \rho g R^2 (H - y) dy = -\frac{1}{2} \int_0^H \pi \rho g R^2 d(H - y) = -\frac{1}{2} \pi \rho g R^2 (H - y)^2 \Big|_0^H = \frac{1}{2} \pi \rho g R^2 H^2.$$

Similarly, set the amount of work A_2 required to raise the entire volume of liquid to the surface of the tank, when the bases of such a cylindrical structure will be located vertically (Figure 7). The equation of the arc of the

base circle in the selected coordinate system is defined as $x^2 + (y - R)^2 = R^2$, where $x = \pm\sqrt{R^2 - (y - R)^2}$, $y \in [0; 2R]$. At an arbitrary height y , the elementary mass of the fluid layer at such an arrangement of a given cylindrical structure will be determined as follows:

$\Delta m_2 \approx 2x\rho H\Delta y$, based on the appropriate formula for determining the volume of an elementary parallelepiped of height Δy . Then the elementary force required to raise to the surface of such a structure all the particles of the liquid from the specified height of the location of such particles in and taking into account the given value of x will be defined as

$$\Delta F_2 \approx 2\rho g H \sqrt{R^2 - (y - R)^2} \Delta y, y \in [0; 2R].$$

So, this elemental force is equal to the force of gravity emitted at the height of the elementary volume for a given fluid. Further, given the fact that the particles of this elementary volume of liquid must be raised to the height of rise $(2R - y)$, the element of work ΔA_2 will be defined as

$$\Delta A_2 \approx 2\rho g H \sqrt{R^2 - (y - R)^2} (2R - y) \Delta y, y \in [0; 2R].$$

As in the first case, replacing the increments of the function and its argument by the corresponding differentials of these infinitesimal quantities, we have a definite expression in the form of a definite integral for the final establishment of the value of the total sum A_2 as follows:

$$\begin{aligned} A_2 &= \int_0^{2R} 2\rho g H (2R - y) \sqrt{R^2 - (y - R)^2} dy = \left(\begin{array}{l} R - y = t \\ dy = -dt \\ t \in [-R; R] \end{array} \right) = \\ &= 2\rho g H \int_R^{-R} (R - t) \sqrt{R^2 - t^2} d(-t) = \\ &= 2\rho g H R \int_{-R}^R \sqrt{R^2 - t^2} dt - 2\rho g H \int_{-R}^R t \sqrt{R^2 - t^2} dt = 2\rho g H R \int_{-R}^R \sqrt{R^2 - t^2} dt = \\ &= 4\rho g H R \int_0^R \sqrt{R^2 - t^2} dt = 4\rho g H R \left. \frac{t\sqrt{R^2 - t^2}}{2} \right|_0^R + 4\rho g H R \left. \frac{R^2}{2} \arcsin \frac{t}{R} \right|_0^R = \pi\rho g R^3 H. \end{aligned}$$

Here $\left. t\sqrt{R^2 - t^2} \right|_0^R = 0$, also $\arcsin 1 = \frac{\pi}{2}$, $\int_{-R}^R t\sqrt{R^2 - t^2} dt = 0$ as an integral of the odd function under the sign of the integral symmetric with respect to the point 0 of the integration interval.

Thus:

$$A_1 = \frac{1}{2} \pi \rho g R^2 H^2,$$

$$A_2 = \pi \rho g R^3 H.$$

Based on the latest results, these values can be compared and their corresponding ratio is taken:

$$\frac{A_1}{A_2} = \frac{H}{2R}, \text{ або } A_1 = \frac{H}{2R} A_2.$$

The following features are obtained:

$$\frac{H}{2R} > 1 \Leftrightarrow H > 2R \Leftrightarrow A_1 > A_2,$$

$$\frac{H}{2R} < 1 \Leftrightarrow H < 2R \Leftrightarrow A_1 < A_2,$$

$$\frac{H}{2R} = 1 \Leftrightarrow H = 2R \Leftrightarrow A_1 = A_2.$$

Thus, the values of the required works in both cases will be equal when the height (generative) H of such a cylindrical structure coincides with its diameter $2R$, which is the logical result of such studies.

It should also be noted that if the position of the cylindrical structure is horizontal at its base, the magnitude of the corresponding work will be proportional to both the square of the radius and the square of the height of such structure (Figure 6), and if such capacity is horizontal with vertical both bases (Figure 7), the magnitude of the desired work will already be proportional to both the cube of the radius of the base circle and the height (creative) of such a structure of the corresponding geometry.

4. Setting the maximum number of filling of some geometric structure with many other geometric figures of circular (spherical) shape

Questions about the optimal location of certain geometric objects (structures) are among the problems of optimal geometric design. Such studies are relevant and their results are constantly growing both from a purely theoretical and practical point of view [7–12]. In the studies, the so-called coefficient of useful filling of one geometric structure with many other objects plays a very important role. As a rule, the main task of such researches is to increase the numerical value of the coefficient and its direct estimation in one or another mathematical model that is being studied [11–12]. The results of them have a wide range of possible applications: the problem of maximum filling of tanks of different geometric shapes in the agricultural sector of the economy, mechanical engineering, medicine, in particular, pharmacology, light, furniture, etc. The basis of such problems and their solution is to determine the optimal location of a finite set of certain geometric objects within certain geometric structures. We aim to calculate the possibilities of maximum filling of a given geometric figure (both flat and three-dimensional) by a set of circles (respectively, balls) of the same radius r , namely, the quantitative component of such optimal filling, and formulate some criteria for estimating such maximum filling. Obviously, such a criterion can be chosen as the ratio of the total usable area (volume) of the filling of a given geometric structure to the area (volume) of this given geometric structure.

The purpose of the researches is to establish the optimal filling of a certain external geometric structure with a finite set of objects of one or another geometric shape, to establish the quantitative characteristics of such filling, to introduce and calculate the coefficient of useful maximum filling of such structure.

In order for the external geometric structure to reach its maximum content, we will require that the linear dimensions of a given geometric structure be multiples of the numerical value $d=2r$ (d -diameter). Under this necessary condition, the area (volume) of unproductive voids of the external geometric structure is minimized and, accordingly, the filling of such a structure will reach the highest values.

1. If in the plane case (ie in two-dimensional space) as an external geometric structure is chosen a rectangle with the dimensions of the

sides, respectively, a and b , whose numerical values are multiples of $2r$, ie $\frac{a}{2r} = m, \frac{b}{2r} = n$, where m, n – integers, then the quantitative value of the optimal (maximum) filling of such a flat geometric structure is easily established and is equal to:

$$N = mn .$$

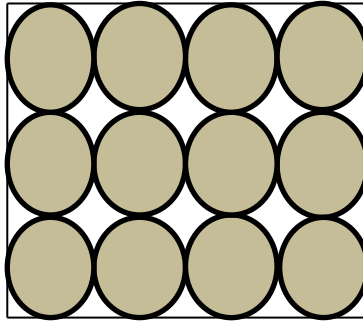

Figure 8. Rectangular structure, where $m = 4, n = 3$

As an example of such a simpler structure, Figure 8 shows a structure in the form of a rectangle with values of $m = 4, n = 3$. Then $N = 12$. Now in this example the degree (coefficient) of efficiency of such filling of the set structure as the relation of the total area of all 12 circles to the area of the set external rectangular structure will be established. Here:

$$\xi = \frac{mn\pi r^2}{ab} 100\% = \frac{mn\pi r^2}{4mnr^2} 100\% = \frac{\pi}{4} 100\% = 78,5\% .$$

An analogue of the above structure, but with the transition to three-dimensional space is a straight parallelepiped, which is filled as much as possible by a set of balls of fixed radius, while the linear dimensions of the independent sides of the parallelepiped meet the conditions:

$$\frac{a}{m} = \frac{b}{n} = \frac{c}{k} = 2r, \text{ where } m, n, k - \text{ integers, } 2r - \text{ diameter of each sphere.}$$

In this case, the maximum possible number of such balls inside the specified parallelepiped will be equal to:

$N = mnk$, the coefficient of useful effective filling of such a structure of three-dimensional space will be determined as the ratio of the total useful

volume to the volume of the outer parallelepiped. Summarizing the example shown in Figure 8 on three-dimensional space and assuming, for example, $k = 3$, the value of this coefficient will be as follows:

$$\xi = \frac{\frac{4}{3}\pi r^3 mkn}{abc} 100\% = \frac{\frac{4}{3}\pi r^3 mkn}{8mnr^3} 100\% = \frac{\pi}{6} 100\% = 52,3\%.$$

From the results of finding the coefficients of optimal filling of similar flat and three-dimensional models, we can conclude that the optimum maximum filling for a flat model is 1.5 times higher than in a similar three-dimensional model. The next conclusion is that the numerical values of the corresponding coefficients of useful filling of flat and three-dimensional structures do not depend on the linear dimensions of the outermost geometric structure.

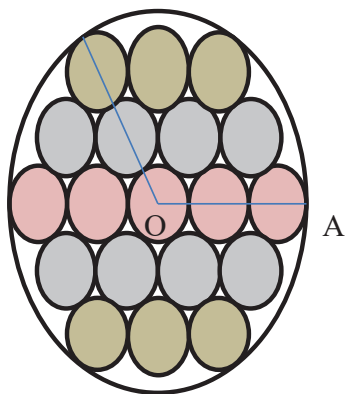

Figure 9. The example of a flat outer circular structure of radius R , maximally filled with a set of circles of fixed radius $r, R > r$ in the case when $\frac{R}{r}$ – is an odd number ($\frac{R}{r} = 5$).

2. As another external geometric structure in two-dimensional space, we introduce a circle of radius $R, (R > r)$, here r – values of the fixed radius of the maximum possible number of inner circles, which fill the area of the outer structure of a large circle. We assume that $\frac{R}{r} = l$, де l – is an integer.

According to the research, this point can be further divided into two sub-items depending on the parity – the oddness of the numerical value of l .

A) Suppose $l = 2k - 1, k - \text{integer}$. The case of the so-called paired model. An example of such a specific structure $k = 3 (l = 5)$ is shown in Figure 9.

The dependence of the maximum possible number of small circles inside the outer circular structure has been established and this dependence is determined by the formula of the following form:

$$N(R = (2k - 1)r) = 2k - 1 + 2 \sum_{i=1}^{k-1} (2k - 1 - i), k = 2, 3, 4, \dots$$

This formula at large values of k is not particularly convenient, so we offer a condensed version, which is more appropriate, it has the following form:

$$N(R = (2k - 1)r) = 3k^2 - 3k + 1, k = 2, 3, 4, \dots$$

According to the latter result, the value of the number N increases in quadratic with respect to k dependence.

Table 1

Dependence of the maximum possible number of small circles on the value of the integer k , which are located inside the large circle

k	2	3	4	5	6
The number of circles N of radius r depending on the value k ($R = (2k-1)r$)	7	19	37	61	91

Using the above result, we can easily set the maximum possible number of small circles to fill a large circle in Figure 9: $N(R = 5r) = 27 - 9 + 1 = 19$.

The established dependence of the number N on the value of k can also be set using table 1.

B) Suppose $l = 2k, k - \text{integer}$. This is the case with the so-called paired model. An example of such a specific structure $k = 3 (l = 6)$ is shown in Figure 10.

In this case, the dependence of the maximum possible number of small circles inside the outer circular structure is determined by the formula of the form:

$$N(R = 2kr) = 2k + 2 \sum_{i=1}^{k-1} (2k - i), k = 2, 3, 4, \dots$$

In this case, the dependence of the maximum possible number of small circles inside the outer circular structure is determined by the formula of the form:

$$N(R = 2kr) = 2k + 2 \sum_{i=1}^{k-1} (2k - i), k = 2, 3, 4, \dots$$

Based on this result, we have a similar quadratic relationship between the values N and k .

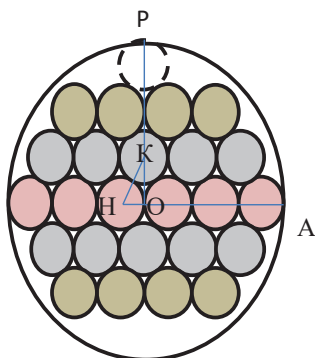

Figure 10. An example of a flat outer circular structure of radius R , maximally filled with a set of circles of fixed radius $r, R > r$, in the case where $\frac{R}{r} - 1$ is an even number ($\frac{R}{r} = 6$).

As a remark to sub-item B) it is noted that visually it is possible to get an impression of the placement of several additional circles, one of which is possible in Figure 10 is dotted. But research has shown that such additional placement is impossible because: $OA = 6r, OP = 3OK + OH = 3\sqrt{3}r + r = (3\sqrt{3} + 1)r \approx 6,1r > 6r$. The established dependence can be similarly interpreted in the form of table 2.

Table 2

Dependence of the maximum possible number of small circles on the value of the integer k , which are located inside the large circle

k	2	3	4	5	6
The number of circles N of radius r depending on the value of k ($R = 2kr$)	10	24	44	70	102

The execution of the last inequality mathematically strictly proves the fact that the presence in Figure 10 of the dotted additional possible circle is actually impossible.

Let us dwell on the question of establishing the value of the coefficient of effective (maximum) filling of such an external circular structure. For the odd model we have the following estimate for this coefficient:

$$\xi_{\text{new}} = \xi(R = (2k-1)r) = \frac{N(R = (2k-1)r)\pi r^2}{\pi R^2} 100\% = \frac{N(R = (2k-1)r)\pi r^2}{\pi r^2 (2k-1)^2} 100\% = \frac{3k^2 - 3k + 1}{(2k-1)^2} 100\% \approx 75\% .$$

It is similarly for the pair model:

$$\xi_n = \xi(R = 2kr) = \frac{N(R = 2kr)\pi r^2}{\pi R^2} 100\% = \frac{N(R = 2kr)\pi r^2}{\pi r^2 (2k)^2} 100\% = \frac{3k^2 - k}{(2k-1)^2} 100\% \approx 75\% .$$

As we can see, the asymptotic values of the given coefficients coincide essentially with one constant value equal to 75%.

Then, based on the principles of calculating the outer circular structure, we can further introduce a cylindrical outer geometric structure with the parameters R – radius of the base circle and H – height in three-dimensional space. In this case, we consider the value of H – to be a multiple of $2r$, where r – is the fixed radius of each of the balls, which can fill the maximum volume of the cylinder. If $\frac{H}{2r} = p$, where p – is an integer, then in relation to the maximum possible number of small balls that can be placed inside the cylinder, we obtain:

$$Q = Np.$$

In this case, the coefficient of maximum useful filling of such a three-dimensional structure is defined as

$$\xi = \frac{\frac{4}{3}\pi r^3 Q}{\pi R^2 H} 100\% = \frac{4}{3} \frac{r^3 Np}{(2k-1)^2 r^2 2pr} 100\% = \frac{2}{3} \frac{3k^2 - 3k + 1}{(2k-1)^2} 100\% \approx 50\% .$$

Thus, we have a similar similarity with respect to the considered external circular structure, namely, the coefficient of volumetric maximum filling is 1.5 times smaller in comparison with the same coefficient of flat filling of the corresponding circular structure.

As follows:

- cases of maximum filling of flat and three-dimensional geometric structures with a finite set of geometric objects are considered, the quantitative measure of each of the given fillings is established;
- the coefficient of such useful filling of the corresponding geometrical structure both in two-dimensional and three-dimensional spaces is entered, the estimation of calculation of such coefficient is made;
- a comparative analysis of such coefficients for flat and three-dimensional cases of solving the problem posed in the research.

5. Conclusions

The main results of the research of this work can be considered the following:

- in the first part of this work, on the example of solving one geometric problem, mathematical versatility of different approaches and methods of solving this particular problem and many other mathematical problems is established, therefore, the question in such cases is not just to find the right solution to the problem to be solved, but also to choose the solution that would be the most acceptable and optimal;
- the second part investigates on the basis of known classical results of one of the physical laws comparative analysis of one of the numerical characteristics, namely, work in this case using the mathematical apparatus of integral calculus, established the relationship of relevant models the body to which the essence of this task is attached;
- in the third part the problem of maximum filling of certain external spatial geometric figures with a set of homogeneous circular or spherical objects is solved, the so-called coefficient of such useful filling is offered and tested.

References:

1. Samovol P. I. (1995). *Metodychna systema roboty iz zdibnymy ta obdarovanymy z matematyky uchniamy v serednii shkoli* [Geometrical design of placing of non-orientable objects from piece by eye-nonlinear borders in multicoherent areas]. Kyiv: National Pedagogical University named of M.P. Drahomanov. (in Ukrainian)
2. Liba I. (2001). *Aktyvizatsiia piznavalnoi diialnosti uchniv* [Activation of students' cognitive activity]. *Mathematics at school*, vol. 2, pp. 44–46. (in Ukrainian)

3. Vygodsky M. Ya. (2019). *Metodychna systema roboty iz zdbnymy ta obdarovanymy z matematyky uchniamy v serednii shkoli* [Handbook of elementary mathematics]. Kyiv. (in Ukrainian)

4. Balash V. A. (1974). *Zadachi po fizike i metody ikh resheniya* [Problems in physics and methods of their solution]. Moscow: Enlightenment. (in Russian)

5. Vinnytsia National Agrarian University (2010). *Zbirnyk naukovykh prats. Serii: Ekonomichni nauky* [Collection of scientific works. Series: Economic Sciences]. Vinnytsia: VNAU.

6. Ovchinnikov P. F., Yaremchuk F. P., Mikhailenko V. M. (2007). *Vyshcha matematika* [Higher mathematics]. Kyiv: Machinery. (in Ukrainian)

7. Bezugla Yu.S. (2016). *Heometrychne modelyuvannya rozmishchennya neoriyentovanykh obyektiv z kusochno-neliniynymy hranytsyamy u bagatozvyaznykhoblastyakh* [Geometrical design of placing of non-orientable objects from kyc by eye-nonlinear borders in multicoherent areas]. Kharkiv: Natsionalnyy universytet tsyvilnogo zakhystu Ukrainy. (in Ukrainian)

8. Ploskiy V. O. (2011). *Systemna klasyfikatsiya MMP: ponyattya pro aktyvne vykorystannya* [System classification of MMP: the concept of active use]. *Prykladna heometriya ta inzhenerna hrafika* [Applied geometry and engineering graphics], vol. 87, pp. 182–188. (in Ukrainian)

9. Vanin V. V. (2014). *Kompyuterne heometrychne modelyuvannya yak isnuyuca osnova avtomatyzovanoho proekuvannya ob'ektiv mashynobuduvannya* [Computer geometric modeling as an existing basis for automated design of mechanical engineering objects]. *Suchasni problem modelyuvannya*, vol. 2, pp. 22–25. (in Ukrainian)

10. Pilipaka S. F. (2013). *Konstruyvannya sferchykh kryvykh u funktsiyj naturalnoho parametra* [Construction of spherical curves as a function of a natural parameter]. *Bioresursy ta pryrodovykorystannya*, vol. 5, no. 3–4, pp. 57–62. (in Ukrainian)

11. Korchynsky V. M. (2011). *Klasyfikatsiya heometrychnykh form ob'ektiv na bagatospektrovykh rastrovnykh zobrazhennyakh* [Classification of geometric shapes of objects on multispectral raster images]. *Prykladna heometriya ta inzhenerna hrafika*, vol. 88, pp. 116–120. (in Ukrainian)

12. Lodi A. (2002). *Two-dimensional packing problems: a survey*. *European Journal of Operational Research*, vol. 141, pp. 241–252.

CHAPTER «HISTORICAL SCIENCES»

ACTIVITIES OF JEWISH SCHOOLS IN PODILLYA PROVINCE IN THE SECOND HALF OF THE XIX CENTURY

Svitlana Bogatchuk¹

DOI: <https://doi.org/10.30525/978-9934-26-193-0-18>

Abstract. The problem of education among the Jewish population in the second half of the nineteenth century attracts the attention of historians and educators. According to scientific and archival sources, statistical data, research examines the issue of education of Jewish children, the opening of educational institutions for them and the activities of Jewish schools in the Podillia province, which began operating in the second half of the nineteenth century. Since the time of socio-economic transformations in the life of the Russian Empire, the corresponding processes in the educational sphere have been taking place. In general, in the state, including in the Podillia province, educational institutions of various directions are gradually opening. These are primary schools, gymnasiums, schools (public, private), theological seminaries. The purpose of the research is to analyze the development of education in the Podolsk province, in particular, among the Jewish population, to conduct a comprehensive analysis of the activities of Jewish schools in the late nineteenth century. Due to the informational and analytical-synthetic methods of research on this topic, the process of formation of education among the population of Jewish nationality in the second half of the XIX century is considered. in Podillya. The main problems that arose due to the discriminatory norm established by the government in the admission of Jewish children to gymnasiums and higher education institutions, which did not allow all those wishing to receive secondary and higher education, were highlighted. It was not comfortable for Jewish children to study with other children. We are trying to analyze

¹ Candidate of Historical Sciences,
Associate Professor of History of Ukraine and Philosophy Department,
Vinnytsia National Agrarian University, Ukraine

that due to the fact that Jews were the third and fourth largest population in the Russian Empire, and in the south-western cities received a significant degree of economic development, it was necessary to open special schools, gymnasium for them. One of the versions about the acquisition of education by the Jewish population is their gradual rapprochement with the Christian population, as P. Chubynsky emphasizes in his work. This was the goal of the authorities in opening 1st and 2nd grade schools, which resulted in the direction of Jews through proper preparation for the transition to general secondary and higher education. It should also be noted that the government decided to open schools for Jewish women, especially from low-income families. Most of them are private schools. At the end of the XIX century the Jewish population of Podillya was characterized by a high level of education. In 1897 it included 41.3% of Jewish men and 21.7% of women.

1. Introduction

A great number of scientific works are devoted to the study of this problem. Interest in the ethnic composition of the population of the Russian Empire, in particular, the Podillya province grew sharply in the 40–50s of the XIX century.

A certain role in the ethnographic study of Podillya was played by the activities of the General Staff of the Tsarist Army to study the provinces of the Russian Empire. The tenth volume of the “Military Statistical Review of the Russian Empire” contains information about the ethnic composition of the population of Podillya, ethnographic descriptions of Ukrainians, Russians, Moldovans, Poles, Jews, Armenians, Greeks, Muslims, etc. [1].

Of great interest in the study of our topic is the work of O. Rittich, which provides tables of population distribution of the nine western provinces of the Russian Empire on religious property, reproduces the ethnic composition of the Western region, contains provincial figures on the ethnic composition of the Podillya province, including Jews (Jewish) [2, p. 17–18].

No less important in the 70s of the XIX century. became ethnographic and statistical work of P. Chubinsky, which examines the life and everyday life of “tribes of non-Russian origin”, namely: Volume 7 is devoted to Jews, Poles. The scientist uses data on religion and native language and determines the ethnic status of the population of the Right Bank of Ukraine, in particular, Podillya province [3].

In the 80s of the XIX century. well-known Podillya historian, local historian, statistician V. Guldman launched the annual “Review of Podillya Province” [4]. Between 1884 and 1913, 25 large books were published depicting the life of the population of Podillya (demography, agriculture, industry, trade, education, culture, medicine, taxes, etc.), which is a unique source for research scholars [5–15]. Ethnographically important is his monograph “Podillya province. The experience of geographical and statistical description” (1889) [16]. It should be noted that a third of the information about the population of Podillya, published in the publications of V. Gouldman, is generally the first source for their study.

The results of scientific research on the Jewish population in the southwestern provinces of Russia are presented in the work of Alenitsyn V.D. “Jewish population and land tenure in the southwestern provinces of European Russia, part of the Jewish settlement” (1884), which includes reports of provincial commissions on the Jewish question [17].

No less important in terms of research is the publication in the early twentieth century 16 volumes of Brockhaus-Efron’s “Jewish Encyclopedia”, which is devoted to knowledge about Jews and their culture [18].

Statistical data on the demographic and cultural status of the Jewish people were studied by Brutskus B.D. “Statistics of the Jewish population: distribution by territory, demographic and cultural characteristics of the Jewish population according to the 1897 census” (1909) [19].

Many scientific works of Ukrainian historians are devoted to the study of this problem, in particular Anokhina L. [20], Vorolis M. [21], Kosholap O. [22], Kononenko V. [23], Morgolis T. [24], Trostogon M. [25], Yurchenko O. [26]. In their publications, they focused only on certain aspects of this topic.

The monograph of Polishchuk Yu. M. “National minorities of the Right Bank of Ukraine in the context of ethnic policy of the Russian Empire (late XVIII – early XX centuries)” reveals the features of Russian tsarist policy towards national minorities of the Right Bank of Ukraine and basic principles of socio-economic, educational, church and religious policies of the Russian Empire [27].

The dissertation research of Orlovsky L.O. “Jewish population in the socio-economic, socio-political, educational, cultural and spiritual life of Podillya (1861–1914)” (2019) is devoted to the economic and national-cultural life of the Jewish community in the second half of the XIX Art. – in the early twentieth century in Podillia [28].

Setting objectives. Today the attention to educational issues has increased. That is why the paper studies and analyzes scientific and statistical sources on the development of education among the Jewish population of Podillya province in the second half of the nineteenth century, especially the activities of Jewish schools, their funding.

The purpose of the research is to try to analyze the development of education in the Podillya province, in particular, among the Jewish population, to conduct a comprehensive analysis of the activities of Jewish schools in the late nineteenth century.

Due to the informational and analytical-synthetic methods of research on this topic, the process of formation of education in Podillya region among the population of Jewish nationality in the second half of the XIX century is considered.

2. The Jewish population in the second half of the nineteenth century

It is necessary to consider what share of the population of the Right Bank of Ukraine was represented by Jews. After the annexation of the Right Bank by the Russian tsarism, an audit of the population was conducted, which was to show the number of individual states of the region.

During the XIX century the absolute number and proportion of the Jewish ethnic group evolved in the direction of increase.

The reason for such dominance of the Jewish community was the imperial policy, which on the basis of the Regulations of 1835 singled out the so-called “settlement strip” for the compact residence of Jews. Its borders covered Podillya, Volyn, Kyiv (except Kyiv city), Kherson (except Mykolayiv), Katerynoslav, Tavriya (except Sevastopol), Poltava (except Cossack and state villages) and Chernihiv provinces [29, p. 66].

P. Chubynsky noted in his work that Jews were not allowed to settle in the territory of the Greater Russian provinces, but only in the western provinces, where they received a significant degree of economic development [3, p. 3–8].

At the end of 1840, Nicholay I established a special committee “to determine measures for the radical transformation of Jews in Russia”. This committee had: “1. to act on the moral education of the new generation of Jews by founding Jewish schools in a spirit contrary to current Talmudic teachings; 2. to destroy the kahals (community) and to subordinate the

Jews to the general government ... 4. to forbid the use of special Jewish clothing ... 7. by dividing the Jews according to the quality of their occupations”. These proposals determined the policy of Nicholay I towards the Jews, which he followed until his death in 1855 [32, p. 500].

According to the materials of the General Staff in 1849, there were 177,189 Jews living in the Podillya province, which was 1/81 of the total population of 1,530,321 people [1, p. 82].

According to official data from 1865, the Jewish population of the South-Western region was already more than 600 thousand people, ie, more than 11% of the population of the region. The largest Jewish communities were in Berdychiv and Zhytomyr [27, p. 107].

It should be noted that in 1867 there were 211,801 Jews living in the Podillya province, which was the second largest (after the Kiev province) among the 9 provinces that were part of the Russian Empire [30, p. 98].

According to statistical calculations, P. Chubynsky determined that in general in the provinces of the South-Western region in 1872 Jews lived: in the Kiev province – 13.09%; in Podillya – 12.08%; in Volyn – 12.37%. That is, Jews in each of these provinces now make up almost one-eighth of the population. It turns out that in cities the number of Jews is over 32%, in towns – 53% and in villages – more than 14% [3, p. 175–178]. Table 1 follows the analysis of the settlement of Jews in cities, towns and villages in the provinces of the South-Western region.

Table 1

Settlement of Jews in the three Southwestern provinces as of 1872

Provinces	Cities	Towns	Villages	Total
Kyiv	98,032	123,909	41,18	263,459
Podilya	70,012	151,124	35,539	246,735
Volyn	69,171	105,223	36,747	211,146
Total	237,275	380,261	103,804	721,340

Source: Chubins'kiy P. (1872) *Yevrei. Polyaki. Plemena nemalorusskogo proiskhozhdeniya. Malorussy (statistika, sel'skiy byt, yazyk) [Poles. Tribes of non-Russian origin. Little Russians (statistics, rural life, language)]. Trudy etnograficheskko-statisticheskoy ekspeditsii v Zapadno-Russkiy kray, snaryazhennoy Imperatorskim Russkim Geograficheskim Obshchestvom. Yugo-Zapadnyy otdel [Proceedings of the ethnographic-statistical expedition to the Western Russian Territory, organized by the Imperial Russian Geographical Society. Southwest Division]. St. Petersburg, p. 608. (in Russian)*

According to statistics for the late 80's of the XIX century in 120 towns of the Podillya province, Jews accounted for 44% (140,598 people) of the total population. At the same time, the smallest number of Jews lived in the towns of Makiv, Kamyanets'kyi district (2.9% – 47 out of 1649 people), Butnivtsi (Podillya) of Letychiv district (4% – 48 out of 1222 people), Verkhivka, Mogilev district (4, 6% – 41 out of 897 people) and in the town of Tina, Ushice County (4.5% – 46 out of 1,023 people). The largest percentage of Jews are in the towns of Holoski in the Balta County (85% – 803 out of 945 people), Chechelnyk, Olgopol County (93% – 2232 out of 2400 people) and Knyazhe-Tymanivka in Yampil County (98% – 5). In 22 towns Jews made up from 40% to 50% of the population [16, p. 92].

In 8 towns, the percentage of Jews was 70-80%, 7 towns out of 10-15% and 6 towns each, where there were 5-10% Jews and 60-70% of the total population. Thus, out of 120 towns in 57, the Jewish part of the population was over 40%. Thus, in the Podillya province and county towns, Jews made up a significant part of the population, in Mogilev and the Baltics their share reached 60-80% [31, p. 125].

The increase in the population of Jewish nationality in the Right Bank of Ukraine (three provinces) in 1884 can be traced in Table 2.

Table 2

Settlement of Jews in the three Southwestern provinces as of 1884

№	Provinces	Population, total	Jews	% Jewish population
1	Kyiv	2.332.421	339.557	14.6
2	Podillya	2.239.514	418.858	18.7
3	Volyn	1.946.438	289.820	14.9

Source: Alenitsin V.D. (1884) Evreyskoye naseleniye i zemlevladieniye v Yugo-Zapadnykh guberniyakh Yevropeyskoy Rossii, vkhodyashchikh v chertu yevreyskoy osedlosti [Jewish population and land ownership in the South-Western provinces of European Russia, included in the Jewish Pale of Settlement]. St.-Peterburg. (in Russian)

According to the census of the Jewish population in the towns of the South-Western region in number is almost 43% of the total population [19, p. 8]. The indicators in Table 3 testify to the settlement of Jews in the towns of the provinces of the Right Bank of Ukraine.

Table 3

Population distribution in the towns of the Right Bank of Ukraine by denominations (1897)

Provinces	Orthodox	Jews	others	Total
Kyiv	319583	196420	21802	537805
%	59,4	36,5	24,1	100
Podillya	226045	210804	38149	474998
%	47,6	44,4	9,0	100
Volyn	179636	192370	23752	395758
%	45,4	48,6	6,0	100
Total	725264	599594	83703	1408561
%	51,5	42,6	5,9	100

Source: Komarnits'kyi O.B. (2004) Ukrayins'ke mistechko: ponyattya, demohrafichnyy, etnichnyy i konfesiynnyy sklad naseleння (na materialakh Pravoberezhnoyi Ukrayiny kintsya XIX – pochatku XX st.) [Ukrainian town: concept, demographic, ethnic and confessional composition of the population (on the materials of the Right Bank of Ukraine in the late XIX – early XX centuries)]. Scientific works of Kamyanets-Podilsky State University: Historical sciences. Kamenets-Podolsky: Otium, Vol. 12, p. 512. (in Ukrainian)

According to the census conducted in the Russian Empire in 1897, the number of Jews (in cities, towns and villages) in the Podillya province alone is 370,612 people. [3, p. 178]. Statistical indicators of the settlement of Jews in the Podillya province are presented in Table 4.

Table 4

The population of Jews in the Podillya province according to the 1897 census

Types of settlement	Total	Jews	%
Villages	2.313.420	54847	2,4
Towns	483,009	212877	44,2
Cities	221.870	102.888	46,4
Total	3.018.299	370.612	12,3

Source: Brutskus B.D. (1909) Statistika yevreyskogo naseleniya: raspredeleniye po territorii, demograficheskiye i kul'turnyye priznaki yevreyskogo naseleniya po dannym perepisi 1897 [Statistics of the Jewish population: distribution by territory, demographic and cultural characteristics of the Jewish population according to the 1897 census]. SPb: Sever, p. 134. (in Russian)

Thus, according to statistical and historical sources, we note that the Jewish population between 1860 and 1890 did increase from 246,735. up to 370,612 people. and is a major part of the demography of the Podillya region.

3. Activities of Jewish schools in the Podillya province

It was very difficult for Jewish children to get an education. In 1844, government schools for Jews and two rabbinical seminaries were established in Vilna and Zhytomyr in the southwestern part of the Russian Empire. Christians were appointed directors of these schools, and only Jewish subjects were taught by Jewish teachers. The main purpose of the schools (secret instruction of the Minister of Education, approved by the tsar) was to re-educate the younger generation and turn the Jews away from the Talmud. At the same time, the establishment of these schools led to the persecution of traditional Jewish schools, the Heders, and their teachers, the Melamedis. Jews tried to bribe officials to keep these schools and compiled fictitious lists of students that local authorities sent to the Ministry of Education [32, p. 500–501].

In the institution the children studied the Jewish Law of Faith, the ancient Hebrew language, the translation of the Bible and the Holy Scriptures, the history of the Bible and after the Bible, Pircate-Avot (explanation of the most important prayers).

According to P. Chubynsky, “Melamedis” are divided into elementary (first-graders, “dardaki-melamedis”), teachers of Hebrew (second-graders, “arbuvia-melamedis”) and teachers of the Talmud (tertiary, “hemara-melamedis”). Quite often classes are held in the room where the “melamedi” lives with his family, which is not always suitable for study [3, p. 80].

Children were taught only by those Melamedis who had received a certificate from the Jewish school commissions (there were two in the province, in Kamianka and Nemyriv). In total in the Podillya province in the mid-70’s of the XIX century there were 409 melameds who taught more than 3.5 thousand children [16, p. 95]. Although there may have been more.

Melamedis were monitored not only by the county’s Jewish school commissions, but even by the police. For violating the rules, they were brought to court, fined together with the parents of children who studied there. After that, the Melamedis were forbidden to teach children, they gave a receipt stating that they would not do it anymore [36, p. 15].

It should be noted that Jewish children who studied in Russian schools were uncomfortable due to the negative attitude towards them in educational institutions, on which the policy of the Russian autocracy was based [26, p. 94].

According to P. Chubinsky's research, Jews who did not receive theoretical knowledge of any of the European languages had difficulty learning the grammatical rules of the Russian language. According to the scientist, Kyiv Jews speak Russian better than Podillya and Volyn Jews. That is, knowledge of the language and its pronunciation depends on the area where they live. It is known that many Jewish families decided to teach their children the Russian language in order to bring them closer to the local population [3, p. 5–15].

According to the new regulation on Jewish schools, in 1844 two higher schools were established (in Vilna and Zhytomyr) for the training of future teachers and rabbis, as well as two kinds of schools: first-class and second-class. A special candle collection was set for the maintenance of the schools and revenues from two monopoly Jewish printing houses in Vilna and Zhytomyr were allocated.

On August 7, 1845, the Provincial Jewish Student Commission was established to control educational institutions, according to which teaching in Jewish educational institutions is unsatisfactory, children only have to memorize knowledge, school premises are in a dirty state [1, p. 152].

According to the law of May 4, 1859, Jews were given the right to teach their children the law of faith, at their own request, in schools or private teachers [28, p. 161].

As of 1857, there were 171 Jewish educational institutions in the Podillya province, of which: 8 public one-level schools (197 students), two-level schools (2 (33 students), private Talmudors – 1 (50 students), private headers (primary schools) – 160 (2475 students) [33, p. 5].

By decree of May 4, 1859, the government decided to improve the teaching staff and make the education of the children of Jewish merchants and honorary citizens compulsory.

In 1861, Jewish teachers of state schools were exempted from paying taxes and performing other duties [27, p. 235].

The decree of September 6, 1862, decided on the expediency of appointing Jewish and Christian caregivers of Jewish schools. And the

emergence of Jewish teachers significantly increases the number of students and interest in the school.

However, it should be taken into account that before the Regulation on the Arrangement of the School Unit in the South-Western Region of May 26, 1869, there were (excluding Kyiv) only 6 county schools, including 4 aristocratic ones. In the second half of 1869 in the South-Western provinces opened 32 folk and urban schools [27, p. 109].

The Minister of Education concluded that studying in special schools alienated Jewish youth from the Christian environment, so in early 1873 an order was issued to close public schools founded for Jews in 1844 and to transform rabbinical schools into teachers' institutes.

At the same time, measures were taken to facilitate the admission of Jews to general educational institutions, but the rapid increase in the number of Jews among them caused great dissatisfaction among various sections of Russian society. Anti-Jewish information appeared in the press [32, p. 505].

According to statistical estimates of P. Chubynsky in the 70s of the XIX century up to 900 boys and up to 300 girls studied in state Jewish schools and private Jewish boarding schools [3, p. 201].

After 1873, a number of new public schools and private schools emerged, existing schools were reorganized, libraries were established, and so on.

According to the Society for the Propagation of Jewish Education in Russia, all special Jewish schools in the 15 provinces had a "settlement zone" (very few outside Jewish schools) by the end of 1899, 644, of which 392 (60%) were privately owned. initiative, 139 (21%) are considered public and charitable, the remaining 113 schools (19%) – public schools established by the educational department [34].

It should be noted that in the second half of the XIX century Podillya province was a polyethnic region, in which, according to the All-Russian census of 1897, Ukrainians accounted for 80.9% of all Podillya residents, Russians – 3.3%, Poles – 2, 3% [35, p. 3]. 31,000 Jews lived in Vinnytsia County. Tailoring and trade in agricultural products were common occupations among the Jews of Vinnytsia [26, p. 87].

On May 3, 1882, the "Provisional Rules" were adopted, which significantly limited the development of Jewish national life. The education system of Jewish communities was tied to the area of settlement and the corresponding quota for education in educational institutions. In July 1887,

the Minister of Education issued a directive establishing an “interest rate”. In secondary and higher state educational institutions this quota was at the level of 10% (this included Podillya). Thus, the authorities tried to isolate Jews or force them to emigrate from the country [23, p. 178].

Podillya province was included in the “settlement zone” of the Jewish population and became one of the most Jewish-populated regions not only in Ukraine but also in the empire. In 1897, 376,017 Jews lived in the province, which was about 12.3% of the total population of the region, most of them women [18, p. 648–649].

Therefore, in the early 70’s of the XIX century throughout the Russian Empire began to open schools for children of Jewish nationality (Jewish school in St. Petersburg, Odessa, Mogilev) [24, p. 1].

Thus, at the end of the XIX century. In Ukraine, in particular, in Podillya, educational institutions of various levels were opened, where Jewish children studied. Among them, single-class Jewish schools and community schools (public Talmudic Torahs, private women’s and men’s Jewish schools) predominated. In addition, there were Jewish teacher training institutes, whose graduates were sent to work in schools. The Jewish schools themselves were located in county towns, such as: Zhytomyr, Vinnytsia, Dunaivtsi, Lityn [25, p. 16].

An important element of traditional Jewish education in the late nineteenth century was the Talmud Torahs, schools for orphans and children from poor Jewish families supported by Jewish communities and donations from wealthy Jews, as well as proceeds from box and candle collections. Although during this period the content of education in them has changed somewhat. In addition to the traditional Jewish religious disciplines (Pentateuch, Hebrew, Bible and Talmud), began to teach some secular sciences [25, p. 18–19].

At the end of the XIX century. Private Jewish men’s and women’s schools began to open on the Right Bank, giving everyone the opportunity to study. Although here, too, the watchful eye of the state was not enough: private Jewish schools were allowed to open only to those who received from the authorities “confirmation of moral and political reliability” [36, p. 16].

In 1877, a two-class elementary Jewish school for men was opened in Vinnytsia, located in a rented house for 825 rubles, and there was a preparatory class at the school. For the maintenance of the school used the

money got from selling candles (candle fee) – 4031 rubles 92 kopecks. 134 boys studied there. Only 10 graduated from school successfully due to the high requirements of teachers [25, p. 17].

In the 70s of the XIX century in the Podillya province, 4 primary state Jewish schools were established, one of which was a two-class Jewish school in Vinnytsia (1877), and three one-class schools in Proskurov (1878), Mogilev Podilsky (1879), and Balti (1875) [16, p. 195].

In 1887, 422 boys and 22 girls studied in four Jewish schools. In total, the maintenance of these children cost 15,559 rubles 50 kopecks, ie the maintenance of one child cost an average of 35 rubles. It should be noted that Jewish schools did not have their own premises and were forced to rent them at the expense of the Ministry of Education, Box and Candle Fees, funded by the candlelight fee of local Jewish communities [4, p. 133]. Regarding the funding of these schools, we can follow in Table 5.

Table 5

**Financing of state Jewish schools in the Podillya province
(1887–1990)**

Year	Financing (rubles)
1887	15.559 rubles 50 kopecks.
1888	13.539 rubles 50 kopecks.
1890	14.550 rubles 14 kopecks.
1891	14.550 rubles 14 kopecks.
1892	13.933 rubles 14 kopecks.
1894	13.933 rubles 14 kopecks.
1895	15.436 rubles 02 kopecks.
1896	15.189 rubles 17 kopecks.
1897	15.502 rubles 37 kopecks.
1898	15.189 rubles 47 kopecks.
1899	15.189 rubles 47 kopecks.
1900	15.189 rubles 47 kopecks.

Source: summered by the auctor [4–16]

The duration of the course in schools was 6 years. In single-grade schools, students were divided according to their knowledge into three departments and studied in each of them for two years. In two-grade schools, the first

grade lasted four years and the students were divided into two classes. The 2nd grade course lasted for two years. Children under the age of seven and at least fourteen were admitted to the Jewish primary school. Children aged 10 to 13 who successfully completed the first four years of school could enter the first grade of gymnasiums and real schools without exams. In the same Jewish schools, the children studied Russian, arithmetic, Russian, Hebrew, and German, ancient Hebrew, Jewish law of faith, Bible history, and important prayers according to programs approved by the Ministry of Education. The same subjects, as well as history and geography, were studied in two-grade schools.

At the Mogilev Jewish School, the children studied at the locksmith's and blacksmith's department. Training was conducted in a separate room for a rent of 112 rubles. in a year. In 1890, a carpentry and binding department was opened, which was taught in the school. A total of 34 students studied in this institution, 20 of them in metalwork, 8 in carpentry, 6 in binding. Tables, chairs, hangers, stools, beds, balcony grilles, folding tables and chairs, locks and more were made for sale [8, with. 190]. The master of metalwork graduated from the Zhytomyr Jewish School, other masters – local. Part of the money for the maintenance of the school is transferred from the candle collection of the Jewish community (100 rubles), the other – 1000 rubles. by box collection, and another part – donations and money received from the sale of goods produced by students [8, p. 135].

In 1895, the Jewish Society of Proskurov filed a petition for 24,000 rubles. for the construction of a new building of the Jewish school. The city has allocated a place for construction. It should be noted that in the survey of the Podillya province, educational work in state-run Jewish schools is considered satisfactory. Teaching in them is conducted intelligently and successfully, as teachers have teaching experience, graduated from Zhytomyr and Vilnius Jewish Teachers' Training Institutes. Also, this document emphasizes that graduates of Jewish schools do not lag behind students of two-grade city schools in terms of knowledge. It should be recalled that Jewish children did not speak Russian at all when entering school. But in the second year of study, they can communicate perfectly with her, both literary and conversational.

In 1895, children were taught carpentry at the Baltic Jewish School. There were 14 boys who studied there, 100 rubles were allocated for their

education. by staff and 1,620 rubles. from the amount of the city box fee. Training was held for 2 hours daily, there were two teachers [11, p. 190].

In addition to public schools, private Jewish schools were popular among Jews. The curriculum of each private institution must be approved by the trustee of the educational district. As a rule, these schools were opened in private homes and were mostly maintained at the expense of individuals or societies, as well as funds from the sums of candle and box fees. For most Jewish girls, private schools were essentially the only place where they could receive primary education.

According to the first All-Russian census of 1897, only 468,769 people (15.5%) were educated in the Podillya province, including in cities – 85008247 (33.8%). There was no one among the peasants who had higher or secondary education. There were 109,971 women with education in Podillya (30.6%). Among the population of different religions, the largest percentage of educated people were Jews (21.7%) and Protestants (71.4%) [35, p. 4–9]. According to the census, Jews can read less than half of the population – adult men, and only a quarter of women, as evidenced by Table 6 [19, p. 195].

Table 6

**Russian literacy of the Jewish population
in the Podillya province according to the 1897 census**

Age	Jewish population		Literacy			
	men	wom.	Absolute number		%	
			men	wom.	men	wom.
From 1 to 9	45.408	45.417	1.749	1.394	3,9	3,1
From 10 to 19	41.927	49.149	14.100	11.035	33.6	22.4
20-29	23.994	31.456	14.445	6.464	49.8	25.5
30-39	20.842	21.396	9.703	2.388	40.7	11.2
40-49	15.785	17.098	5.358	906	33.9	5.3
50-59	11.230	12.166	2.801	407	25.0	3.3
60 -	9.078	8.426	1.894	168	20.9	2.0
Total	168.264	185.108	50.050	22762	28,0	12,0

Source: *Brutskus B.D. (1909) Statistika yevreyskogo naseleniya: raspredeleniye po territorii, demograficheskiye i kul'turnyye priznaki yevreyskogo naseleniya po dannym perepisi 1897 [Statistics of the Jewish population: distribution by territory, demographic and cultural characteristics of the Jewish population according to the 1897 census]. SPb.: Sever, p. 134. (in Russian)*

Thus, we note that schools, public and private schools, despite discriminatory actions by the authorities, have contributed to improving the level of education among Jewish children. After all, the percentage of young people under the age of 29 is the highest.

4. Activities of Vinnytsia Women's Jewish School

Emigration determined the predominance of women in the Jewish population. It was at the end of the XIX century began to pay attention to the need to improve the material and moral situation of Jewish women. One such step was the education of Jewish girls, as discussed in this section.

And according to the results of the 1897 census (Table 6), we can see that at the end of the XIX century. Jewish women do not have an advantage in education over men. Among women aged 10 to 19, only 22% speak Russian, and women aged 20 to 29 make up 25.5% of educated population.

The network of women's secondary schools was being built on the Right Bank very slowly, even in comparison with other regions of Ukraine, as the government artificially restrained their growth.

On May 10, 1860, a draft of a new regulation on women's schools of the Ministry of Public Education was approved, according to which two councils were established at each school: a board of trustees and a pedagogical council. The main idea of the provisions of 1858–1860 was to leave the nature of private schools behind women's schools.

In 1867 the first Russian women's gymnasium (Mariinsky) was opened in the provincial center. Thus, the issue of women's secondary education in the Podillya province was resolved. It was subordinated to the Main Council of Women's Educational Institutions of the Empress Maria Feodorovna. It was the only women's gymnasium in the Podillya region of this department, which lasted more than 50 years – until the end of 1917 [21, p. 60].

In 1887, a women's Jewish school with a free handicraft class was founded by Minna Rubinstein. It was noticeably popular among the impoverished population of Vinnytsia County. Teachers I. Rubinstein, V. Eidelmashan, M. Gorenstein, A. Skulsky and M. Linitzka had a relevant education after graduating from the Zhytomyr Jewish Pedagogical Institute. It should be added that teachers demanded from their students a deep and complete mastery of the material, adhered to didactic and methodological principles of teaching [25, p. 19].

Every year, 50 to 60 girls from the poorest Jewish families were admitted to study. The main attention was paid to the study of Russian as a colloquial language. The girls studied literacy, accounting and women's needlework. After introducing the study of the German language, it became clear that language skills would no longer be used. Therefore, it was decided to focus teachers' efforts on mastering needlework and sewing [37, p. 37].

When teaching Jewish subjects, attention was paid to the students' study of the rules of slang, the basic rules of the Hebrew language, knowledge of catechism, the most necessary prayers and biblical history. All of these subjects were taught exclusively in Russian according to the curriculum for the Jewish school, which was not disputed by the students' parents. The teaching of these subjects was entrusted to an experienced teacher [38, p. 26].

Students were required to acquire knowledge of Russian history and geography in accordance with the program of public schools in the South-Western region [39, p. 16]. In addition, the girls were taught Russian and Jewish elementary literacy because they did not have the opportunity to attend a regular school.

In the educational work among children, important attention was paid to mastering the rules of morality, respect and love for religion, love and respect for parents and mentors, special attitude to the sacred person of the Emperor. 1-2 times a week they sang Russian, ancient Jewish and the best slang folk songs, as well as prayers to prevent the negative impact of street obscene songs.

Teachers of the school, brought up in conditions of strict discipline, accordingly demanded from their students [39, p. 16]. The feedback from parents on the upbringing of their children was only positive, because the students received excellent rules of accuracy and decency at school, learned to control themselves, became more disciplined, what was a pleasure.

The education of children from different social backgrounds required management to take into account the ability of parents to pay for education. Not all parents could pay for their children's education in full. Most of the funds for the maintenance of the institution came from parents, from the amount of box and candle collection, subsidies from the Committee of the Crafts Fund, as well as from the Society for the Dissemination of Education among Jews in Russia [40, p. 8].

In 1892, a handicraft class was opened at the school, thanks to the financial support of the Committee of the Crafts Fund, which helped low-income students learn to sew and later earn a living. The foundation paid for the first two years of their studies. Thus, for 6 years, 57 Jewish girls studied at the school for free [37, p. 11].

Maintaining a needlework class required significant costs: 10 rubles per student. For 15 girls it turned out 150 rubles. It was a lot of money, in difficult years, the founder of the school herself conducted needlework classes. In 1897, a master was invited, who selected 12-15 girls, taught them exclusively sewing, forming a workshop. In the workshop, students learned to sew underwear, dresses, and even received orders from people not associated with the school. The Committee of the Crafts Fund allocated a sewing machine for temporary use for 70 rubles.

The founders of the school, despite the difficult financial situation of the institution, in February 1897 opened Saturday classes to help Jewish girls who could not read or write, could not get an education [40, p. 8].

In 1897, after five years of study, the best graduate of the school was recommended to enter the Vinnytsia Women's Gymnasium Olena Kholodykova on preferential terms of payment [37, p. 42].

In difficult times for the school, some residents of Vinnytsia came and taught needlework for free, brought books (167 pieces), clothes for the poorest students. For example, Rosalia Reicher gave 5 rubles for the purchase of Jewish textbooks. For 10 years of work (1887–1897) the school graduated 505 graduates, of which 153 – for free [37, p. 39 stars].

The management, students and graduates of the school thanked their sponsors who helped pay for the education of the poorest children, which allowed them to receive education for future life.

It should be noted that the opening of educational institutions for Jewish children by the government was an act of great humanity. Not all Jewish families were able to pay for tuition, and in ordinary schools and colleges it was difficult for these children to adjust. Therefore, children were given to hard work when they were young.

Thus, the opening of a private women's Jewish school in Vinnytsia provided opportunities for girls from poor Jewish families to learn the basics of literacy, religion, history, as well as learn to sew and various handicrafts.

5. Conclusions

Thus, in the studied Podillya region, a fairly extensive network of educational institutions of public, private and spiritual Jewish education was created, which was under the constant strict control of the state, which pursued a policy of Russification of the Jewish population.

Melamedis, or scribes, traditionally taught children, and were divided according to the scope of teaching into primary (darkedemelamdin) and secondary (irbuvya-melamdin). The educational institutions attended by Jewish children were called headers. These were primary schools for boys, where education began at the age of four. The main content of the study was the study of the Torah and Jewish theological literature.

Contrary to the assimilation policy of the tsarist government, the traditions of national education were preserved in Jewish educational institutions, and the Jewish language and rites were studied.

The opening of 4 state Jewish schools in the Podillya province contributed to the further involvement of children in grammar, geography, other subjects and professions, such as: locksmith, carpenter, blacksmith for boys, sewing, needlework for girls.

Children from poor Jewish families attended the schools (wealthier Jews tried to educate their children in secondary schools, which made it easier for graduates to enter the empire's universities).

So, if in the 40-50s of the XIX century the government forced Jews to go to school to study Russian, but in the 1880s they almost closed access to schools, setting a 10% quota. Thus, the authorities tried to pursue a policy of transition from the assimilation of the Jewish population to the actual isolation or emigration.

The respectful attitude of Jewish communities to education, their contribution to the financing of education contributed to the fact that at the end of the nineteenth century. According to the level of literacy on the Right Bank of Ukraine, in particular, in Podillya, Jews ranked fourth, leaving far behind Ukrainians who were forbidden to study in their native language. Only Czechs, Germans, and Russians were superior to Jews in education.

It is this approach to the disclosure of the activities of educational institutions, in particular, schools where Jewish children were educated, and allows to recognize their level of education.

References:

1. Tveritinov (1849). Voyenno-statisticheskoye obozreniye Rossiyskoy imperii [Military Statistical Review of the Russian Empire]. Podillya province. (in Russian)
2. Rittikh A. F. (1864). Atlas narodonaseleniya Zapadno-Russkogo kraya po ispovedaniyam [Atlas of the population of the Western Russian Territory according to confessions]. SPb. (in Russian)
3. Chubins'kiy P. (1872). Yevrei. Polyaki. Plemena nemaloruskogo proiskhozhdeniya. Malorussy (statistika, sel'skiy byt, yazyk) [Poles. Tribes of non-Russian origin. Little Russians (statistics, rural life, language)]. *Trudy etnograficheskoye-statisticheskoy ekspeditsii v Zapadno-Russkiy kray, snaryazhennoy Imperatorskim Russkim Geograficheskim Obshestvom. Yugo-Zapadnyy otdel* [Proceedings of the ethnographic-statistical expedition to the Western Russian Territory, organized by the Imperial Russian Geographical Society. Southwest Division]. St. Petersburg, p. 608. (in Russian)
4. Gul'dman V. (1888). *Obzor Podol'skoy gubernii Prilozheniye ko Vsepoddaneyshemu otchetu Podol'skogo gubernatora* [Overview of the Podillya province Supplement to the Most Submissive Report of the Podillya Governor]. Kamianets-Podil'skiy: Gub. tip. (in Russian)
5. Gul'dman V. (1889). *Obzor Podol'skoy gubernii za 1888 god: Prilozheniye ko Vsepoddaneyshemu otchetu Podol'skogo gubernatora* [Overview of the Podillya province for 1888: Appendix to the Most Submissive Report of the Podillya Governor]. Kamianets-Podil'skiy: Pod. gub. stat. komitet. (in Russian)
6. Gul'dman V. (1890). *Obzor Podol'skoy gubernii za 1889 god: Prilozheniye ko Vsepoddaneyshemu otchetu Podol'skogo gubernatora* [Overview of the Podillya province for 1889: Appendix to the Most Submissive Report of the Podillya Governor]. Kamianets-Podil'skiy: Pod. gub. stat. komitet. (in Russian)
7. Gul'dman V. (1891). *Obzor Podol'skoy gubernii za 1890 god: Prilozheniye ko Vsepoddaneyshemu otchetu Podol'skogo gubernatora* [Overview of the Podillya province for 1890: Appendix to the Most Submissive Report of the Podillya Governor]. Kamianets-Podil'skiy: Pod. gub. stat. komitet. (in Russian)
8. Gul'dman V. (1892). *Obzor Podol'skoy gubernii za 1891 god: Prilozheniye ko Vsepoddaneyshemu otchetu Podol'skogo gubernatora* [Overview of the Podillya province for 1891: Appendix to the Most Submissive Report of the Podillya Governor]. Kamianets-Podil'skiy: Pod. gub. stat. komitet. (in Russian)
9. Gul'dman V. (1893). *Obzor Podol'skoy gubernii za 1892 god: Prilozheniye ko Vsepoddaneyshemu otchetu Podol'skogo gubernatora* [Overview of the Podillya province for 1892: Appendix to the Most Submissive Report of the Podillya Governor]. Kamianets-Podol'sk: Pod. gub. stat. komitet. (in Russian)
10. Gul'dman V. (1895). *Obzor Podol'skoy gubernii za 1894 god: Prilozheniye ko Vsepoddaneyshemu otchetu Podol'skogo gubernatora* [Overview of the Podillya province for 1894: Appendix to the Most Submissive Report of the Podillya Governor]. Kamianets-Podil'skiy: Pod. gub. stat. komitet. (in Russian)
11. Gul'dman V. (1896). *Obzor Podol'skoy gubernii za 1895 god: Prilozheniye ko Vsepoddaneyshemu otchetu Podol'skogo gubernatora* [Overview of the Podillya

province for 1895: Appendix to the Most Submissive Report of the Podillya Governor]. Kamianets-Podilskyi: Pod. gub. stat. komitet. (in Russian)

12. Gul'dman V. (1897). *Obzor Podol'skoy gubernii za 1896 god: Prilozheniye ko Vsepoddaneyshemu otchetu Podol'skogo gubernatora* [Overview of the Podolsk province for 1896: Appendix to the Most Submissive Report of the Podillya Governor]. Kamianets-Podilskyi: Pod. gub. stat. komitet. (in Russian)

13. Gul'dman V. (1898). *Obzor Podol'skoy gubernii za 1897 god: Prilozheniye ko Vsepoddaneyshemu otchetu Podol'skogo gubernatora* [Overview of the Podillya province for 1897: Appendix to the Most Submissive Report of the Podolsk Governor]. Kamianets-Podilskyi: Pod. gub. stat. komitet. (in Russian)

14. Gul'dman V. (1899). *Obzor Podol'skoy gubernii za 1898 god: Prilozheniye ko Vsepoddaneyshemu otchetu Podol'skogo gubernatora* [Overview of the Podillya province for 1898: Appendix to the Most Submissive Report of the Podillya Governor]. Kamianets-Podilskyi: Pod. gub. stat. komitet. (in Russian)

15. Gul'dman V. (1900). *Obzor Podol'skoy gubernii za 1899 god: Prilozheniye ko Vsepoddaneyshemu otchetu Podol'skogo gubernatora* [Overview of the Podillya province for 1899: Appendix to the Most Submissive Report of the Podillya Governor]. Kamenets-Podol'sk: Pod. gub. stat. komitet. (in Russian)

16. Gul'dman V. (1889). *Podol'skaya guberniya: Opyt geograficheskoy i statisticheskoy opisaniya* [Podillya province: Experience of geographical and statistical description]. Kamianets-Podilskyi: Printing house of the Podillya provincial government. (in Russian)

17. Alenitsin V. D. (1884). *Êvreyskoye naseleniye i zemlevladieniye v Yugo-Zapadnykh guberniyakh Yevropeyskoy Rossii, vkhodyashchikh v chertu yevreyskoy osedlosti* [Jewish population and land ownership in the South-Western provinces of European Russia, included in the Jewish Pale of Settlement]. St.-Peterburg. (in Russian)

18. Garkavi A., Katsnel'son L. (1912). *Yevreyskaya entsiklopediya: svod znaniy o yevreystve i yego kul'ture v proshlom i nastoyashchem* [Jewish Encyclopedia: a collection of knowledge about Jewry and its culture in the past and present]. St.-Peterburg: Brokgauz-Yefron. (in Russian)

19. Brutskus B. D. (1909). *Statistika yevreyskogo naseleniya: raspredeleniye po territorii, demograficheskiye i kul'turnyye priznaki yevreyskogo naseleniya po dannym perepisi 1897* [Statistics of the Jewish population: distribution by territory, demographic and cultural characteristics of the Jewish population according to the 1897 census]. SPb.: Sever, p. 134. (in Russian)

20. Anokhina L. S. (1998). Z istoriyi osvity u m. Vinnytsi (II pol. XIX – poch. XX st.) [From the history of education in Vinnytsia (II half of the XIX – early XX centuries) *Podil's'ka starovyna*, pp. 91–117. (in Ukrainian)

21. Vorolis M. H. (2009). Stan pochatkovoyi osvity v deyakykh rehionakh Ukrayiny naprykintsi XIX – poch. KHKH st.: z haduyut'sya navch. Zakl [The state of primary education in some regions of Ukraine in the late XIX – early XIX centuries. XX century: mentioned in the textbook]. *Naukovi zapysky Vinnyts. derzh. ped. un-tu im. M. Kotsyubyns'koho. Seriya: Istoryia: zb. nauk. pr.*, no. 15, pp. 59–61. (in Ukrainian)

22. Kosholap O. F. (2011). Rozvytok yevreys'koyi osvity na Podilli v 1914–1920 [Development of Jewish education in Podillya in 1914–1920]. *Zbirnyk naukovykh prats' Khmel'nyts'koho instytutu sotsial'nykh tekhnolohiy Universytetu "Ukrayina"*, no. 3, pp. 88–93. (in Ukrainian)

23. Kononenko V. V. (2011). Natsional'na osvita yevreys'kykh hromad Podillya na Podilli: mynule ta s'ohodennya [National education of Jewish communities of Podillya Education in Podillya: past and present]. *Vseukr. nauk. ist.-krayezn. konf. 20-21 zhovt. 2011 r.: do 100-richchya zasnuvannya VDPU im. M. Kotsyubyns'koho*. Vinnytsya, pp. 177–181. (in Ukrainian)

24. Morgolis T. (1887). *K shkol'nomu voprosu* [On the school question]. Voskhod. May, pp. 1–5. (in Russian)

25. Trostohon M. A. (1994). Pochatkova yevreys'ka osvita u Vinnytsi v kintsy XIX – pochatku XX st. [Primary Jewish education in Vinnytsia in the late 19th and early 20th centuries]. *Proceedings of the second historical and local lore conference "Vinnytsia: past and present", dedicated. 50th anniversary of the liberation of Vinnytsia from Nazi invaders*. Vinnytsia, pp. 16–18. (in Ukrainian)

26. Yurchenko O. (2015). Rozvytok osvity na Podilli na pochatku XX st. [Development of education in Podolia in the early twentieth century]. *Bulletin of the KNLU. Series: History, Economics, Philosophy*, no. 20, pp. 87–98. (in Ukrainian)

27. Polishchuk Yu. M. (2012). *Natsional'ni menshyny Pravoberezhzhya Ukrayiny u konteksti etnichnoyi polityky Rosiy's'koyi imperiyi (kinets' XVIII – pochatok XX st.)* [National minorities of the Right Bank of Ukraine in the context of ethnic policy of the Russian Empire (late XVIII – early XX centuries)]. Kyiv: IPIEND named after I.F. Kuras NAS of Ukraine, 432 p. (in Ukrainian).

28. Orlovs'kyy L. O. (2019). *Yevreys'ke naseleння v sotsial'no-ekonomichnomu, suspil'no-politychnomu, osvith'o-kul'turnomu i dukhovnomu zhytti Podillya (1861–1914 rr.)* [The Jewish population in the socio-economic, socio-political, educational, cultural and spiritual life of Podillya (1861–1914)] (PhD Thesis), Kamenets-Podolsky: Ivan Ogienko National University of Kamyants-Podilsky. (in Ukrainian)

29. Morozova A. (2009). *Yevreys'ke naseleння Livoberezhnoyi Ukrayiny v druhyi polovyni XIX – na pochatku XX st.* [The Jewish population of the Left Bank of Ukraine in the second half of the XIX – early XX centuries]. Kyiv, p. 300. (in Ukrainian)

30. Veytsblit I. I. (1930). *Rukh evreys'koyi lyudnosti na Ukrayini: periodu 1897-1926 rokiv* [The movement of the Jewish people in Ukraine: the period 1897–1926]. All-Ukrainian. Academy of Sciences, Institute of Jewish Culture. Social and economic section. Kremenchug, State Publishing House of Ukraine, p. 175. (in Ukrainian)

31. Komarnits'kyy O. B. (2004). *Ukrayins'ke mistechko: ponyattya, demografichnyy, etnichnyy i konfesiynyy sklad naseleння (na materialakh Pravoberezhnoyi Ukrayiny kintsya XIX – pochatku XX st.)* [Ukrainian town: concept, demographic, ethnic and confessional composition of the population (on the materials of the Right Bank of Ukraine in the late XIX – early XX centuries)]. Scientific works of Kamyants-Podilsky State University: Historical sciences. Kamenets-Podolsky: Oium, vol. 12, p. 512. (in Ukrainian)

32. Ettinger Sh. (1990). *Ocherk istorii yevreyskogo naroda* [Essay on the history of the Jewish people]. Iyerusalim: Biblioteka-Aliya, p. 512. (in Russian)

33. Pamyatnaya knizhka Podol'skoy gubernii na 1859 god [Commemorative book of the Podillya province for 1859]. Kamenets-Podol'sk: "Podol. Gub. Vedomostey". (in Russian)

34. ESBE. Shkol'noye delo u yevreyev Entsiklopedicheskiy slovar' Brokgauza i Yefrona [Schoolwork among the Jews Encyclopedic Dictionary of Brockhaus and Efron]. Available at: https://ru.wikisource.org/wiki/%D0%AD%D0%A1%D0%91%D0%95/%D0%A8%D0%BA%D0%BE%D0%BB%D1%8C%D0%BD%D0%BE%D0%B5_%D0%B4%D0%B5%D0%BB%D0%BE_%D1%83_%D0%B5%D0%B2%D1%80%D0%B5%D0%B5%D0%B2 (in Russian)

35. Pervaya Vseobshchaya perepis' naseleniya Rossiyskoy imperii 1897 g. XXXII [First General Census of the Russian Empire in 1897. XXXII]. Podol'skaya guberniya. 1904. (in Russian)

36. Krichker O. Yu. (2012). Tradytsiyi pochatkovoyi osvity v yevreys'kykh obshchynakh mistechok Pravoberezhnoyi Ukrayiny na zlami XIX–XX stolit' [Traditions of primary education in the Jewish communities of the towns of the Right Bank of Ukraine at the turn of the XIX–XX centuries Scientific works]. *Naukovi pratsi. Chornomors'koho derzhavnoho universytetu imeni Petra Mohyly. Ser.: Istoriya*, no. 159, vol. 171, pp. 14–17. (in Russian)

37. Derzhavnyy arkhiv Vinnyts'koyi oblasti [State Archives of Vinnytsia Region]. F. 230, op. 1, part 677, pp. 30–45. (in Ukrainian)

38. Bohatchuk S. S. (2018). Diyal'nist' Vinnyts'koho zhinochoho yevreys'koho uchylyshcha naprykintsi XIX st. [Activities of Vinnytsia Women's Jewish School at the end of the XIX century]. *Scientific Bulletin. Collection of scientific works*, no. 130, pp. 25–27.

39. Otchet popechitelya Kiyevskogo uchebnogo okruga o sostoyanii yevreyskikh uchilishch za 1889 god [Report of the trustee of the Kiev educational district on the state of Jewish schools for 1889]. (1890).

40. Orlovskyy L. O. (2015). Stan yevreys'koyi osvity Podillya u druhiy polovyni XIX – pochatok XX st. [The state of Jewish education in Podillya in the second half of the XIX – beginning of the XX century]. *Collection of scientific articles. Scientific search*, part 6, pp. 7–12.

THE RIGHT-BANK UKRAINE INDUSTRIAL PRODUCTION AND
INTRA-REGIONAL SPECIALIZATION
IN THE MID-19TH CENTURY

Yurii Boiko¹

DOI: <https://doi.org/10.30525/978-9934-26-193-0-19>

Abstract. The proposed section of the collective monograph is devoted to the industrial development analysis of the Right-Bank Ukraine three provinces' (Kyiv, Podillia, Volyn) with a total area of 154643 sq. km and a population of 4683860 in the mid-1840s. That was the time when the first clear signs of commodity industrial production appeared in a large number of local landowners' estates, took place the spread of manufacturing, focused mainly on local raw materials and the local market. It was in the mid-1840s that not only descriptive but also statistical sources of historical and economic orientation became widespread, which is greatly expanding the researcher's ability to create reconstructive models of ancient times economic processes.

The *purpose* of our study is to identify the nature and degree of industrial specialization of the Right-Bank Ukraine' 36 districts in various industries, marketability of production through its volume, fixed in monetary terms.

The research *methodology* is determined by the features of the information base, which combines descriptive and statistical sources. Accordingly, first we give a general description of the local industry, its raw material base, organization and technology, the approximate range of consumers. In the second stage, based on the statistical data presented in the relevant tables, we use multidimensional statistical cluster analysis to make a meaningful classification of 36 districts by the nature and direction of their industrial specialization. As a result, we obtain a model which elements are grouped by common qualitative characteristics, the distance (degree of similarity or difference) between objects and groups can be measured by multidimensional scaling (in our case – the distance in

¹ Candidate of Historical Sciences, Associate Professor of the Department of Ukraine History and Philosophy, Vinnytsia National Agrarian University, Ukraine

Euclidean space). Macrogroup A from 7 districts of the northern part of the region with a population nearby 799600 was received 85,8% of industrial revenues from the processing of livestock products. Macrogroup E united 14 districts, mainly in the southern zone of the Dnieper Right-Bank, with a population of 1616370. It was characterized by in-depth specialization in the plant origin products processing, from which 96,7% of industrial profits were received. Macrogroup C represented by one district of Kyiv with the central regional city and a total population of 176280. Only here 76,5% of industrial profits came from the processing raw materials of mineral origin. Macrogroup D includes 8 districts in the south of the Right Bank with a population of 1090600 people and natural conditions equally suitable for crop and livestock production. Hence the balance of the processing industry and revenues from it – 48,5% of processing of crop products and 44,5% of processing of livestock products. Macrogroup B included 6 districts with a population of 816350, whose farms did not have a narrow production specialization: 26,1% of industrial profits came from processing of plant products, 33,6% from processing of livestock products, 40,3% of industrial profits from processing of minerals.

The *practical significance* of our study is that the results obtained can be used in the construction of broader paleoeconomic reconstructions, in the educational process, in writing scientific articles and monographs.

The *originality* and *scientific novelty* of the work lies in the formulation of the problem, the methodology used, the results obtained. Such a study for the Right-Bank Ukraine region of the mid-1840s is conducted for the first time.

Introduction

The middle of the 19-th century is an important time in the Eastern Europe history. The era of feudalism is coming to its final stage, and a transitional period of social and economic reforms of the 1860s and 1880s is approaching, aimed at bringing the Russian Empire on the main path of capitalist development. Despite the stagnant nature of the predominantly agrarian economy, several leading industrial regions of the empire European part with their specialization were formed in the 1830s–1850s [12; 16; 20], which became an important prerequisite for the formation of an all-Russian market to the end of the century.

These processes could not but affect the Ukrainian lands, the boom of the industrial renaissance of which occurred in the last quarter of the 19-th century. Among the three regions of the then Ukraine in terms of the main parameters (ethnic, religious, social, economic) the most unique was the Dnieper Right-Bank, which includes the lands of the historical Kyiv, Podillya, Volyn provinces. In contrast to the Left Bank (Little Russia) and the South (New Russia) of Ukraine in the middle of the 19-th century there was the highest level of serfdom [9], which contributed to the concentration of industrial production in landlords' estates using cheap labor dependent peasants. In the mid-1840s almost 86% of production in the Kyiv province was concentrated in private estates. It was determined by the availability of significant free capital from landlords, opportunities for self-financing and obtaining significant loans, and the use of excess serfs labour in the processing of agricultural products [19, pp. 2–3]. The owners of the enterprises produced mineral commodities also received considerable profits.

The aim of our study is to identify, as far as possible, the achievements of this option of primary industrialization by building a statistical model of intra-regional industry specialization, tied to the market through the share of individual industries in total industrial profit.

Let us consider the main types of industrial production on the three main industries – processing of crop products, processing of livestock products, products using raw materials of mineral origin.

1. Processing crop products

1.1. Distillation

It should be noted, that contemporaries regarded distillation as a “fake industry”, perceiving it as a convenient form of storage and a profitable way to sell part of the grain, potato, and fruit crops to landlords, use the excess labour of dependent peasants, and increase local prices for grain, fuel. Most often, statistics did not include the distillery in the list of industrial enterprises, indicating only the total volumes of excise goods. However, all economists agreed that the production and sale of vodka products were important factors in filling the state budget – 46% in 1859 (look, for example: [8, pp. 222–224; 15, p. 305; 18, p. 171]). That is why we, following the then experts on this issue, provide a brief description of the development

of distillation in the Right-Bank Ukraine of the middle of the 19-th century without entering the volume of its products in the Table 1.

The Kyiv province. According to the data for 1846, in the Kyiv province on the estates of the lords, which occupied 2331718 desyatinas of land and used the labour of 348813 male serfs, there were 384 operating distilleries. Their total production amounted to 4710104 buckets of vodka and alcohol out of 533105 quarters of grain. The total cost of produced alcohol of different quality amounted to 1593310 rubles with absolute profitability after its implementation, 25%. Vodka factories were located in Cherkaskyi, Kyivskiy and Chyhyrnskiy districts and put on the market about 57430 buckets of their products (3.4% of all distillery production). At the same time, 375550 buckets of beer, 12520 buckets of honey were brewed at 77 breweries, and the total annual production of vodka, beer and honey was estimated at 220900 rubles [18, pp. 170–176]. P.K. Menkov provided other data on the productivity of distillery in the Kiev province of the mid-1840s: 208 distilleries produced 2500000 buckets of “foamy wine” for 752599 rubles, the last figure we meet in the K.I. Arsenyev’s publication [2, p. 125; 15, p. 305]. According to data from the beginning of the 1850s, 3253420 buckets of alcoholic beverages were produced in 362 operating distilleries of the Kyiv province, of which up to 300000 buckets were exported outside the region [5, p. 62; 12, pt. II, p. 77].

The Podillia province. On the landlords estates of the late 1840s there were 182 distilleries that produced 2529492 buckets of alcohol, including from potatoes that were mixed with grain, for a total of 1011800 rubles at a selling price of 6070780 rubles. In the Baltskiy district, the landowner Ruzhitskiy produced up to 600 buckets of vodka from sugar production wastes [3, p. 120–121].

In 1860, 388 distilleries worked in the Kyiv province, 328 in the Volyn and 251 in the Podillia, where 18208583 buckets of alcoholic beverages were produced. Among these enterprises, only two in the Kyiv province had a capacity of 100000 buckets per year, and 85% were small enterprises [8, p. 296, 298, 304–305].

The Volyn province. Features of the Volyn raw material base did not contribute to the significant development of distillation. In 1846–1849, the average annual production amounted to 1206397 “foam wines” and 841839 buckets of “trial wine” [4, p. 95]. “Foam wine” meant the best brand

The Right-Bank Ukraine industrial production in 1845–1847

Provinces / districts	Industries and production amounts in rubles (Profit share by industries %)						Total
	1. Processing crop products	%	2. Livestock processing	%	3. Manufacture of mineral products	%	
<i>The Kyiv</i>	3346180	52,2	1043368	16,3	2020212	31,5	6409760
Kyivskiy	43130	1,7	555600	21,8	1948802	76,5	2547532
Berdychivskiy	47715	50,3	45668	48,1	1490	1,6	94873
Cherkaskiy	2153220	99,6	0	0,0	9170	0,4	2162390
Chyhyrinskiy	556000	98,2	0	0,0	10100	1,8	566100
Kanivskiy	183890	43,8	206900	49,3	29300	7,0	420090
Lypovetskiy	38250	91,4	0	0,0	3580	8,6	41830
Radomyshl'skiy	34880	22,3	114100	73,1	7150	4,6	156130
Skvyrskiy	12500	16,6	60800	80,8	1970	2,6	75270
Tarashchanskiy	66275	88,5	0	0,0	8650	11,5	74925
Umanskiy	52370	83,9	10050	16,1	0	0,0	62420
Vasylykivskiy	77950	60,8	50250	39,2	0	0,0	128200
Zvenyhorodskiy	80000	100,0	0	0,0	0	0,0	80000
<i>The Podillia</i>	512939	73,6	132395	19,0	51449	7,4	696783
Kamianetskiy	103744	90,3	9968	8,7	1200	1,0	114912
Baltskyi	128144	87,0	19200	13,0	0	0,0	147344
Bratslavskiy	31700	72,1	12000	27,3	240	0,5	43940
Haisynskiy	40100	78,5	10605	20,8	358	0,7	51063
Letychivskiy	8975	46,6	1490	7,7	8800	45,7	19265
Litynskiy	66219	82,0	13170	16,3	1375	1,7	80764
Mohylivskiy	23865	62,5	13220	34,6	1100	2,9	38185
Olhopil'skiy	14400	88,8	1820	11,2	0	0,0	16220
Proskurivskiy	21405	37,3	23594	41,1	12390	21,6	57389
Ushytskiy	17720	40,5	22021	50,3	4027	9,2	43768
Vinnyskiy	53287	71,0	3851	5,1	17959	23,9	75097
Yampil'skiy	3380	38,3	1456	16,5	4000	45,3	8836
<i>The Volyn</i>	578403	52,7	406487	37,0	112954	10,3	1097844
Zhytomyrskiy	11200	20,6	15820	29,1	27403	50,4	54423

(End of Table 1)

Provinces / districts	Industries and production amounts in rubles (Profit share by industries %)						Total
	1. Processing crop products	%	2. Livestock processing	%	3. Manufacture of mineral products	%	
Dubenskyi	9280	22,0	32550	77,1	400	0,9	42230
Kovelskyi	515	14,5	3040	85,5	0	0,0	3555
Kremenetskyi	9420	16,3	32550	56,4	15715	27,2	57685
Lutskyi	0	0,0	81510	100,0	0	0,0	81510
N.Volynskyi	36467	31,3	33428	28,7	46507	40,0	116402
Ostrozkyi	0	0,0	52700	100,0	0	0,0	52700
Ovrutskyi	13446	62,4	3370	15,7	4716	21,9	21532
Rivnenskyi	10995	7,7	131075	91,7	825	0,6	142895
Starokonstantynivskyi	18620	41,6	14031	31,3	12148	27,1	44799
Volodymyrskyi	360	3,4	4913	46,7	5240	49,8	10513
Zaslavskyi	468100	99,7	1500	0,3	0	0,0	469600
Right-Bank Ukraine	4437522	54,1	1582250	19,3	2184615	26,6	8204387

of vodka, which was obtained from the light fraction of “simple wine” by additional distillation over low heat using charcoal filters (“pervach”). 100 buckets of “pervach”, diluted with 24 buckets of pure spring water, produced “foamy wine”, which was equal in price to grape wines; “Trial wine” – vodka obtained by breeding 100 buckets of grain alcohol with 331/3 buckets of water for sale in taverns, especially popular in the first half of the 19-th century [13, p. 183–184].

1.2. Sugar industry

The Kyiv province. The first sugar factory in the Kyiv province was founded in 1834 in the estate Orlovets of Cherkaskyi district by Count Leo Pototskyi. Other enterprises were opened a few years later in Zvenyhorodsky and Lypovetsky districts. However, a real breakthrough in this matter began in the 1840’s after the successful launch in 1838 of the Smilyanskyi sugar cluster by Count Alexei Bobrinskyi. After 10 years, 37 sugar factories with

28 steam boilers, 11 steam engines and 247 hydraulic presses were already operating in the province. Cherkasy was the first in the number of factories and sugar production. Most of the enterprises belonged to the landlords and were located on their estates.

The publication of I.I. Fundukley contains the classification of sugar factories contemporary to him: 1) producing the highest quality refined sugar; 2) producing sugar-sand with the possibility of subsequent refining, where there were steam devices used; 3) producing sugar-sand in stone buildings; 4) producing sugar-sand on an open fire in stone buildings; 5) producing sugar-sand over an open fire in wooden buildings. The sugar factory of Count Bobrinskiy in Smila in 1847 was estimated at 145500 rubles (two of his predecessors burned at a cost of 32000 and 58000 rubles). The second-class plant costed the owner 100000 rubles, the third – almost 85000 rubles. The total value of all sugar enterprises in the Kyiv province at the end of the 1840s amounted to 3172000 rubles. During the season, they processed 7154230 poods of beets to produce 258099 poods of white sugar and 18867 poods of yellow. The total costs of sugar factories in the Kyiv province for production in 1846–1847 amounted to 1216919 rubles, gross profit – 1635535 rubles and net profit of 418455 rubles. A desyatina of sugar beets yielded an annual gross income of 144 rubles, a net income of 36 rubles. The most profitable enterprises were in Cherkasky and Chyhyrinsky districts (22 – 28%). During the production season of 1846, sugar factories in the Kyiv province used: firewood 39,916 sq. sazhen, straw for fire 800 sazhen, animal coal 235055 poods, lime 10417 poods, and also 11927 workdays of dependent peasants. The income of participants and suppliers of works, except for the owners, amounted to 1161887 rubles, including 88000 rubles for the workers' wages [19, p. 13–26, 36, 39, 45–46, 47, 75]. In 1853, there were 72 sugar factories in the province, at which 13,135 workers produced goods worth 2600000 rubles. In 1859, 31859 workers were employed at 75 sugar factories in this province, and they produced 9923739 rubles worth of products. Five years later, sugar production reached 10146096 rubles with a reduction in the number of employees to 20583. The density of sugar factories in the south of the Kyiv province at that time was one of the highest in the world [1, pp. 42–44; 11, p. 334–334; 12, pt. II, p. 77].

The Podillia province took second place after the Kyiv province in sugar production. In 1845–1846, there were 25 sugar factories, where they

produced products for 308900 rubles. Such plants were small and used beets, which were grown on 30-100 desyatinas of fields near the plant; a producer bought part of the beets from the peasants of neighboring villages at a price of 40 kopecks for a quarter. The main sugar plants were located in the city of Kamyanets and in the districts of Lityn and Vinnytsia. At the beginning of the 1850s, 37 sugar factories operated in Podillia with 3487 workers, who produced sweet products on 650000 rubles. After nine years, the number of industries decreased to 30, but the number of workers increased to 5850 people and production volumes to 1125242 rubles [4, p. 121–122, Appendix, table 13; 7, p. 182; 12, pt. II, p. 161].

The Volyn province. The development of sugar production in the Volyn significantly lagged behind the neighboring provinces of the Right-Bank Ukraine. In 1848 there were only 10 sugar factories with an annual production volume of 635970 rubles, and only at the Shepetivskyi refinery plant the annual cost of production amounted to 469600 rubles. In 1853, there were already 14 sugar factories with 1034 workers and a production capacity of 855000 rubles for the season. Ten years later, the Volyn sugar-makers at five enterprises using 1184 workers produced 1365080 rubles [14, p. 98, Appendix, table 5; 7, p. 160; 12, pt. II, p. 40].

In 1864, in three Right-Bank Ukrainian provinces, sugar was produced on 13044720 rubles [7, p. XIV].

1.3. Mill business

The Kyiv province. In 1847, there were 3008 mills, including 1964 (65%) watermills and 1044 (35%) windmills. Another 107 mills were driven by machines or horses. More water mills were located in the districts of Uman and Skvyra, and windmills were spread in four southern districts – Zvenyhorodskyi, Chyhyrynskyi, Cherkaskyi and Kanivskyi. In water mills, an average of 3 to 6 quarters of the grain can be crushed into flour per day, in windmills, up to 4 quarters. During the year, 2099950 quarters of grain were processed at all the mills in the province [19, p. 96–103]. P.K. Menkov in his work cited other data on the number of mills: water 2223 wind 880, floating on the Dnieper and Prypiat 123 [2, table on p. 126]. Mills also worked in large numbers in Volyn and Podillia, but reliable statistics on this issue were not available in the publications until the beginning of the 20-th century [11, p. 184 (Compare: 17, p. 63)].

In addition to these industries of the first group of enterprises, associated with the processing of crop products in the middle of the 19-th century, it was customary to include paper making, weaving, pasta, tobacco, cable factories and some others [19, p. 4]. As of the end of the 1840s, the production volume of this kind of industry was estimated throughout the Right-Bank Ukraine at a rate of about 4740000 rubles per year and amounted to 73% of the gross industrial income of the region. In terms of production, the absolute first place was occupied by Cherkaskyi district (2153220 rubles), followed by Chyhyrnskyi, Zaslavskyi, Baltskyi, Kamyanetskyi districts with a significant lag (Table 1) [3, Appendix, table 13; 4, Appendix A; 19, p. 4–9].

2. Livestock processing

2.1. Clothes manufactories

The Kyiv province. In the first half-mid 19-th century among the numerous clothes manufactories, several stood out with their equipment and production volumes. The first of them was founded by Joseph Poniatovskyi in the town of Tahancha, Kanivskyi district in 1806. At first, 10 machine tools worked here and made 3,000 rubles from plain clothes of low-grade wool in year. In 1815, the owner

invited the famous Belgian craftsman Yans, who mechanized production using the latest equipment at the time. In 1838, there were already 120 machine tools working here along with 12 types of other machines, including 41 steam-acted, 39 water, 16 horse and 213 manual-acted ones. The number of workers increased to 670 people. Top-grade wool was partially produced in the estates of Poniatovskyi (800 poods), bought at fairs in Romny and Berdychiv. The annual demand for raw materials was 4600 poods. There were produced 9 types of products painted in 16 colors and shades in the amount of 257027 rubles. Sales occurred mainly on the spot to merchants from adjacent and remote provinces, partly to order at the indicated addresses in Kharkiv, Sumy, Kursk and other cities. Dyes were purchased in Odessa, Berdychiv, Romny, Kharkiv, partially made on the spot, as well as nap cones. Profitability of production ranged from 17 to 21%.

The Korsun clothes factory was founded in 1815 in the same Kanivskyi district. Production was focused on meeting local needs for relatively cheap clothes. The annual gross income amounted to 37922 rubles with

production costs of 32539 rubles, and net profit of 14%. The Khabensk clothes factory existed since 1822 in the estate of Princess Radziwill of the Radomyshl'skyi district and belonged to the mechanic Yans along with the agronomist Ther and the princess herself. Since 1832, the princess redeemed shares of associates and became the sole owner of the enterprise. In 1846, 362 persons worked here, including 275 serfs. In 1845, clothes was sold to the cities of Ryl'sk, St. Petersburg, Moscow, Chisinau, Kursk, Berdychiv, in the provinces of the Volyn, Podillia, Kyiv, and Kherson in the amount of 212667 rubles. Another well-known clothes factory, which was located in the town of Stebliv in the same Kanivskyi district, was moved here in 1845 by the landowner Golovinskyi from another estate. Spinning and weaving machines, up to 100 in number, were driven by a water engine on the Ros River. The factory employed 422 workers, including 9 foreigners, made woollen fabrics a year worth a total of 94000 rubles. Other clothes factories were significantly smaller. The total production of clothes in the Kyiv province in 1845 amounted to 264872 arshins. In 1853, 11 clothes enterprises with 1479 workers produced 262000 arshins of products worth 520000 rubles. In the next decade, production did not increase, and the number of enterprises and employed workers gradually decreased [12, pt. II, p. 76; 11, p. 257; 19, p. 119–142].

The Podillia province. The first clothes factory in Podillia began to work in Tulchyn in the 70s of the 18-th century in the estate of Count Stanislav Pototskyi. In 1845, there were already 105 clothes factories with annual production of 49736 rubles. According to 1853, at 112 enterprises with 1069 workers, 380000 arshins of clothes were produced in the amount of 350000 rubles. By the beginning of the 1860s, 39 specialized manufactories were operating in Podillia, mainly in the Novoushytsky district, where the most noticeable was the enterprise in the village of Dunayivtsy, with annual production of 260500 rubles [3, p. 122, Appendix, table 13; 11, p. 248–249, 251; 12, pt. II, p. 161].

The Volyn province. Among the local landowners, who were engaged in various industries, Princess Sangushko, the owner of the half of Zaslavskyi district, was especially notable. In her clothes factory in the town of Slavuta, where 380 workers, annually produced 50000 arshins of various woollen fabrics with a total value of 113000 rubles. In the town of Rozhnytsia, Lutskyi district, 70000 arshins of clothes were annually produced at the

factory of Princess Karolina Chetvertinska. In the village of Simonov, Ostrozkyi district, the cost of production amounted to 25000 rubles. At 14 other clothes enterprises of this region, goods for 20000 rubles were produced, and at 40 factories of the Rivne district for 120000 rubles. At the beginning of the 1850s there were 105 clothes manufactures here, where up to 3000 persons worked and 450000 arshins of fabrics were produced in the amount of about 500000 rubles. Near the end of the decade, the number of enterprises decreased by a third, and production fell by 35% [4, p. 96–97; 11, p. 248; 12, pt. II, p. 40].

2.2. Hides processing

The Kyiv province. The largest tannery was located in the suburbs of Kyiv, Kurenivka-on-Syrets, and first belonged to a foreigner Lange, and in 1837 it was bought from him by the merchant Serebrennikov. Among the 65 craftsmen employed at the enterprise, 27 were burghers, 9 were the one-dwellers, 29 were the landlords' peasants of the Orel, Kaluga, Kostroma, Moscow and Kyiv provinces. The working day lasted from 4 o'clock in the morning until the evening with three breaks for food due to the owner of the plant. Raw materials were bought in Novogeorgievsk, Orel, Odessa, Balta, Yelisavethrad, and Kyiv directly from the butchers and at fairs in Kharkiv, Sumy, Berdychiv and other cities. The annual volumes of raw materials were: 42000 cow leathers for morocco, 15000 pieces of bovine leather, and other 4500 pieces. For the process the tannin bark needed up to 60000 poods, lime 1000 quarters, barley 2000 poods, rye 900 poods, fish oil 500 poods, birch tar 300 poods, tar 700 poods, wood 200 cubic sazhen. For lighting in winter, 40 poods of sebaceous candles were used. Annual direct and overhead production costs amounted to 209330 rubles, profit 352000 rubles, net profit 143000 rubles. Other large plants were located in Bila Tserkva and Borodianka, Kyivskiyi district. At the beginning of the 1850s, 33 tanning enterprises operated in the Kyiv province, with 318 workers producing 120000 hides worth 620000 rubles. In the early 1860s, during the crisis of manufacturing, the volume of leather products in the Kyiv province fell to 393283 rubles [11, p. 333; 12, pt. II, p. 76; 19, p. 147–159].

The Podillia province lacked the products of its immediate neighbours. Small tannins were located mainly in the Mohylivskiyi and Proskurivskiyi

districts, and the annual production did not exceed 27100 rubles. A few years later, production volumes decreased to 4500 rubles [3, Appendix, table 13; 12, pt. II, p. 161].

The Volyn province. In the late 1840s, 37 small leather manufactories were operating here, in the early 1850s there were already 74, where 30000 leathers and 11000 sheepskins were processed for a total of 65000 rubles [4, Appendix A; 12, pt. II, p. 40].

2.3. Getting animal fat and candle production

In the middle of the 19-th century animal fat was an important technical product, without which many other industries transport, military affairs and daily households could not do. No wonder it occupied the second place in the export of the Russian Empire on the world market after grain bread. Lard heating factories were located near the places of mass slaughter of cattle. From the bull 7-8 poods of fat were heated.

The Kyiv province. The merchant Khodunovskiy's factory for the production of sebaceous candles in Kyiv processed 15000 poods of raw fat from cattle and sheep per year, a third of which was disposed of as waste. The plant worked 7-8 months a year, because the cold weather needed to make candles. The production involved 3 craftsmen and 17 another persons who worked 12 hours a day. For the season, 10000 poods of candles and 8000 poods of soap were made for 64000 rubles, net profit was 26865 rubles. Candle factory in Kyiv, owned by the merchant Bubnov, produced goods for 16000 rubles with a net profit of 610 rubles. The merchant Finke's Kyiv stearin factory produced 2500 poods of candles, had a gross profit of 21600 rubles and net profit of 8000 rubles a year. All 36 workers (16 adults and 20 adolescents) belonged to the landlords' peasants, betrayed by the owner to practice state duties. Worked from 6 am to 7 pm., they ate three times a day for half an hour for breakfast and dinner and an hour for lunch. In total, there were 5 such plants in Kyiv with annual production of 186000 rubles. In the provincial districts in 1845-1848, another 16 candle factories operated with annual production of 148159 rubles. In the early 1850s there were 14 such enterprises in the province with an annual output of 100000 rubles [2, p. 159; 11, p. 193; 12, pt. II, p. 77; 19, p. 159-168].

The Podillia province. In the mid-1840s, 17 lard heating plants were operating in Podillia, the production of which was estimated at 49736 rubles

in year. Of these, 14 worked on local raw materials in Balta, where they fattened 14250 rubles annually, for which 3000 cattle, 7000 sheep, 2500 goats were slaughtered using an additional 560 poods of pork. The Balta lard heating plants sent their products to Odessa. The Mohyliv plant of much lower capacity used cattle from neighboring Bessarabia [3, p. 122].

The Volyn province. At the candle factory of Princess Sangushko in Slavuta, Zaslavskiy district, the best in the province, for the year were made tallow candles for 2500 rubles. There were 23 candle factories in the late 1840s with a total production of 47119 rubles in year [4, p. 98; 11, p. 193].

Soap factories, animal oil mills, and wax mills also belonged to this kind of industry. The gross output of animal processing enterprises on the Right-Bank was approaching 1600000 rubles, or 24% of the region's industrial production. According to the volumes of production of this group, the districts of Kyiv, Kaniv, Radomyshl, Rivne were distinguished (Table 1).

3. Manufacture of mineral products

3.1. Metallurgy and metalworking

The Kyiv province. The first Kyiv iron plant was founded by Old Believers Degtiarev merchants' family from the Kaluga province with an investment of 57920 rubles. The owners bought raw materials (copper, iron) at the Nizhny Novgorod Fair. Annually, sheet copper for 12-15 thousand rubles was supplied for processing, copper of own production costed 6000 rubles, cast iron – 10-20 thousand rubles. Cast iron was bought mainly at the Kyiv Arsenal in the form of discharged old artillery shells and at the merchant Maltsev's factory on 5000 rubles annually. In addition, English steel for 5000 rubles were used for the manufacture of high quality goods primarily for the new bridge in Kyiv. The average annual cost of raw materials and various other materials amounted to 50000 rubles. Copper and brass used for making equipment for sugar factories and distilleries, pharmacies, cavalry cuirasses and kitchen utensils worth up to 21000 rubles a year. Cast iron tombstones, fences, stairs, stoves and parquet for city squares, presses, gears, spare parts for agricultural machinery, weights, grids, stoves, various things on individual projects worth 26000 rubles per year were made from cast iron. Steam boilers for sugar factories were made of sheet steel for 7500 rubles. The total cost of production in 1847 amounted to 75211 rubles.

Marsh ore deposits were discovered in a number of villages in the Radomyshl district. The low-quality iron obtained from them was used for the manufacture of simple agricultural tools for peasants and for sale in the towns of Kyiv and Volyn provinces.

The Podillia province. In the middle of the 19-th century three metal processing plants operated in Podillia: in the village of Cherny Ostrov of the Baltskiy district were castings for 670 rubles made of bronze; in the town of Proskuriv the plant manufactured copper products at 748 rubles; in Bratslav, Vinnitskiy district, a more powerful plant operated with an annual production volume of 15830 rubles. All raw materials for them were imported from the Russian provinces [3, p. 125].

At the beginning of the 1850s, 14 metallurgical and metal-working enterprises with a total production of 120000 rubles were operating in the Kyiv province [2, p. 111–112; 12, pt. II, p. 77; 19, p. 168–175].

The Volyn province. In the late 1840s, the metallurgical and iron foundries of the Volyn were concentrated in Zhytomyrskiy, Ovrutskiy and Novohrad-Volynskiy districts. In the four best iron foundries, 200 workers produced cast iron for 20000 rubles. At 98 other metallurgical enterprises, about 500 workers produced iron and simple tools for 25000 rubles. At the beginning of the next decade, 51 enterprises produced almost 10000 poods of pig iron for 15000 rubles. Many peasants engaged in marsh iron mines, providing themselves with simple equipment [4, p. 95; 12, pt. II, p. 40–41].

3.2. The manufacture of bricks and other building and decoration materials from ceramics

The Kyiv province. One of the largest private brick factory was founded in the suburbs of Kyiv in 1833 by the pharmacist Heisman. There were 4 ovens and 8 barracks for making raw billets. Clay in an amount of up to 700 cubic sazhen and up to 1000 cubic sazhen of fire-wood for bricks was used annually. The bricks were modelled from April 15 to September 15 and burned all year round. In 1848, 2000000 pieces of brick were produced here with a net profit of 2930 rubles. The Gudim-Levkovich's brick-and-tile factory of in Kyiv manufactured its first products back in 1765 and was one of the oldest operating in the Right-Bank Ukraine to the middle of the 19-th century. Since 1810, they began to produce tiles from Hlukhiv and Mezhihiria clay. The net profit of the enterprise amounted to 890 rubles,

or 37% of current assets. In total, in the early 1850s in the Kyiv and the province there were 6 small tile enterprises and 406 brick factories with an annual production volume of 439250 rubles [11, p. 138; 19, p. 210–217].

In the Volyn province, 236 people worked in 43 small brick factories, in the Podillia there were 13 such plants with an annual production volume of 15755 rubles [3, Appendix, table13; 12, pt. II, p. 40, 161].

3.3. Faience and porcelain manufactories

The Kyiv province. The Mezhihiria faience and porcelain state manufactory was founded on the site of a former monastery at the turn of the 18-th and 19-th centuries near Petrivska Mountain with deposits of white pottery clay, when 228 peasants of the state village of Novi Petrivtsi were assigned to it with an annual salary of 36 rubles and the payment of state taxes for them by the Kyiv Magistrate. The plant management was entrusted to a foreigner Kranich with an annual salary of 1200 rubles and 10% of net profit from manufactured products. To this end, he committed himself to presenting the best way to make ceramics, such as English, and teach the boys his skills. The cost of the plant production in 1847 amounted to 31000 rubles. Dishes were sold in Kyiv in a special store and at the factory, where merchants from Kyiv, Chernihiv, Poltava, Kharkiv, Vitebsk, Mogilev, other western and southern cities and provinces came. In 1859, this state-owned manufactory produced goods worth 35500 rubles [11, p. 304; 19, p. 187–206].

The Volyn province. In the town of Baranivka, Novohrad-Volynskyi district, a powerful porcelain and earthenware factory was located with an annual production of porcelain ware on 16000 rubles. At the end of the 1850s, there were 5 similar industries with an annual output of 32000 rubles [4, p. 98; 11, p. 304].

3.4. Glassworks

The Kyiv province. The largest growth in glass production in the Kyiv province occurred in the 20-30s of the 19-th century, when there were 9 enterprises with 142 workers, mainly serfs. Later their number did not increase, satisfying exclusively the local population needs [11, p. 295].

The Volyn province. In the late 1840s, the best glass factories in the Volyn were located in Novohrad-Volynskyi district, near the village of Huty-

Dzikunsky and in the village of Kryvali, where they each year made glass products for 4000 rubles in total. In the early 1850s there were already 27 workshops with 440 workers, where goods for 60000 rubles were produced [4, p. 95; 12, pt. II, p. 41].

This group of industries included also enterprises for the production of smoking pipes, tiles, vitriol, lime, millstones etc. The total value of goods produced in the Right-Bank Ukraine from mineral raw materials amounted to 430000 rubles, or 6% of the value of local products produced by industry. The first place in terms of production was taken by Kyivskiy district with the city of Kyiv (Table 1).

In 1846, 1562 industrial enterprises worked in the Kyiv, Volyn and Podillia provinces, of which 86% were in rural areas [68, p. 25]. The total industrial production of the Right-Bank Ukraine in the late 1840s approached 8204380 rubles (Table 1). In the 1860s, it grew 2,8 times, mainly due to an increase in sugar production [6, p. 23].

4. Intra-regional model of the industrial production organization

Extensive statistical material presented in Table 1, allowed construction a spatial model of the structural organization of industrial production of Right-Bank Ukraine in the middle of the 19-th century. Extensive statistical material presented in Table 1 allowed us to build a spatial model of the structural organization of industrial production of the Right Bank Ukraine in the mid-nineteenth century, using data from 36 counties and 3 provinces and the possibility of multidimensional cluster analysis. There were 5 macrogroups of objects, organized by specialization in one of the industries, a combination of several or no clear specialization at all (Table 2; Figure 1). Consider them in descending order of specialization.

Macrogroup A (Table 2; Figure 1; 2). It includes 7 districts of the northern part of region with a population of 799600. A characteristic feature of their economy was the receipt of 85,8% of industrial profits from the processing of livestock products.

Macrogroup E (Table 2; Figure 1; 2). It united 14 districts, mainly in the southern zone of the Dnieper Right- Bank, with a population of 1616370. It is characterized by in-depth specialization in the plant origin products processing, from which 96,7% of industrial profits were received.

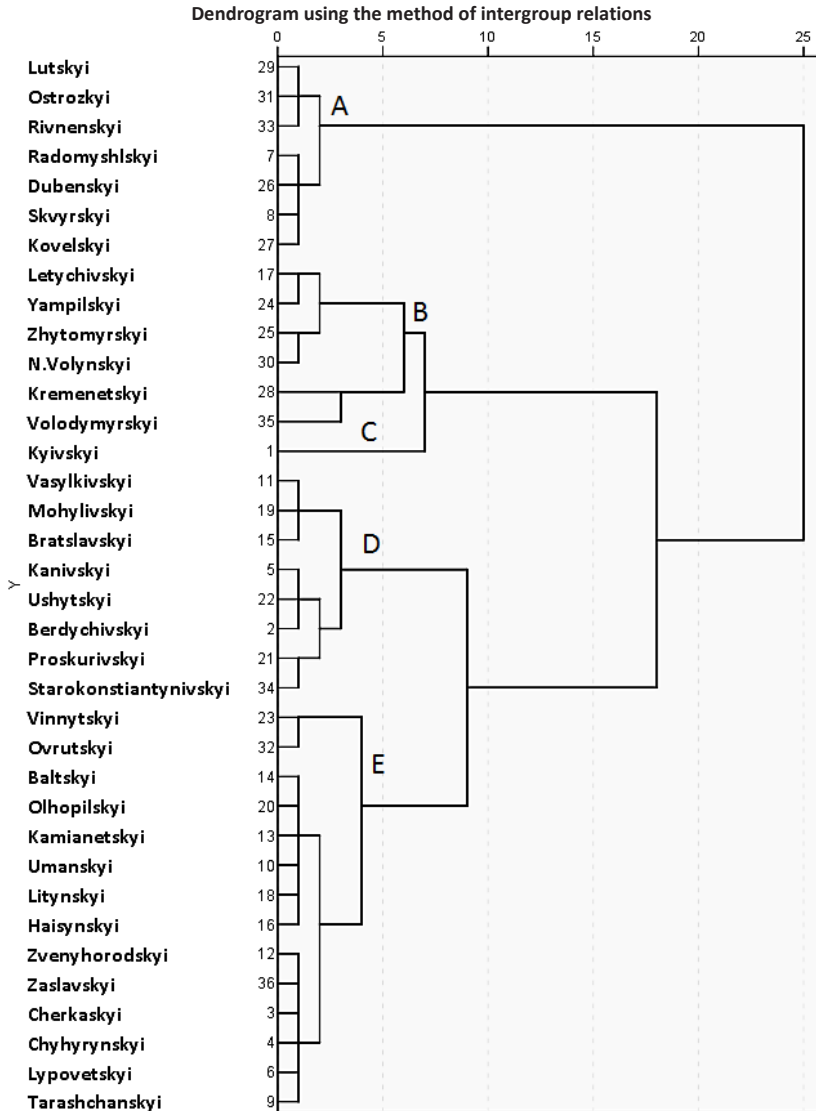

Figure 1. The Right-Bank Ukraine districts cluster classification by industries' profit share

Macrogroup C (Table 2; Figure 1; 2). It is represented by only one district of Kyiv with the central regional city of Kyiv with a total population of 176280. Unlike all other territories, 76,5% of industrial profits here came from the processing raw materials of mineral origin.

Macrogroup D (Table 2; Figure 1; 2). It united 8 districts in the south of the Right-Bank with a population of 1090600 and natural conditions equally suitable for crop and livestock production. Hence the balanced nature of the processing industry and revenues from it – 48,5% processing of crop products and 44,5% processing of livestock products.

Macrogroup B (Table 2; Figure 1; 2). It includes 6 districts with a population of 816350, which farms did not show narrow industrial specialization: 26,1% of industrial profits came from the processing of plant

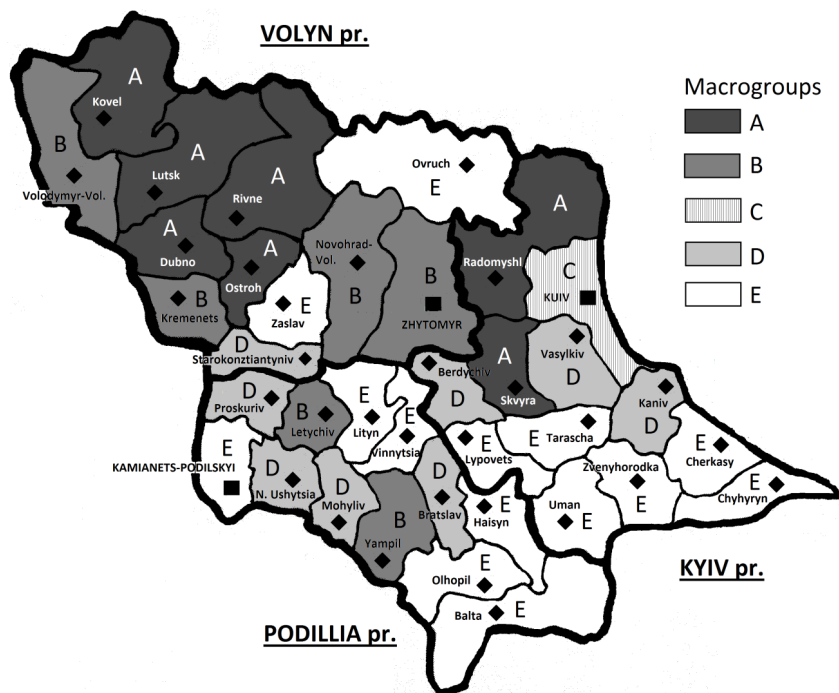

Figure 2. Cartogram of the Right-Bank Ukraine intra-regional industrial specialization in the mid-19th century

Districts classification results by industries' profit share

Provinces / districts	Industries and production amounts in rubles (Profit share by industries %)						Total
	1. Processing crop products	%	2. Livestock processing	%	3. Manufacture of mineral products	%	
Macrogroup A	68170	12,3	475775	85,8	10345	1,9	554290
Lutskiyi	0	0	81510	100	0	0	81510
Ostrozkyi	0	0	52700	100	0	0	52700
Rivnenskyi	10995	7,7	131075	91,7	825	0,6	142895
Radomyshl'skyi	34880	22,3	114100	73,1	7150	4,6	156130
Dubenskyi	9280	22,0	32550	77,1	400	0,9	42230
Skvyrskyi	12500	16,6	60800	80,8	1970	2,6	75270
Kovelskyi	515	14,5	3040	85,5	0	0	3555
Macrogroup B	69802	26,1	89657	33,6	107665	40,3	267124
Letychivskyi	8975	46,6	1490	7,7	8800	45,7	19265
Yampil'skyi	3380	38,3	1456	16,5	4000	45,3	8836
Zhytomyr'skyi	11200	20,6	15820	29,1	27403	50,4	54423
N.Volyn'skyi	36467	31,3	33428	28,7	46507	40,0	116402
Kremenetskyi	9420	16,3	32550	56,4	15715	27,2	57685
Volodymyr'skyi	360	3,4	4913	46,7	5240	49,8	10513
Macrogroup C	43130	1,7	555600	21,8	1948802	76,5	2547532
Kyivskyi	43130	1,7	555600	21,8	1948802	76,5	2547532
Macrogroup D	422865	48,5	387684	44,5	60695	7,0	871244
Vasylkivskyi	77950	60,8	50250	39,2	0	0	128200
Mohylivskyi	23865	62,5	13220	34,6	1100	2,9	38185
Bratslavskyi	31700	72,1	12000	27,3	240	0,5	43940
Kanivskyi	183890	43,8	206900	49,3	29300	7,0	420090
Ushytskyi	17720	40,5	22021	50,3	4027	9,2	43768
Berdychivskyi	47715	50,3	45668	48,1	1490	1,6	94873
Proskurivskyi	21405	37,3	23594	41,1	12390	21,6	57389
Starokonstantynivskyi	18620	41,6	14031	31,3	12148	27,1	44799
Macrogroup E	3833555	96,7	73534	1,9	57108	1,4	3964197
Vynnytskyi	53287	71,0	3851	5,1	17959	23,9	75097

(End of Table 2)

Provinces / districts	Industries and production amounts in rubles (Profit share by industries %)						Total
	1. Processing crop products	%	2. Livestock processing	%	3. Manufacture of mineral products	%	
Ovrutskyi	13446	62,4	3370	15,7	4716	21,9	21532
Baltskyi	128144	87,0	19200	13,0	0	0	147344
Olhopilskyi	14400	88,8	1820	11,2	0	0	16220
Kamianetskyi	103744	90,3	9968	8,7	1200	0	114912
Umanskyi	52370	83,9	10050	16,1	0	0	62420
Litynskyi	66219	82,0	13170	16,3	1375	1,7	80764
Haisynskyi	40100	78,5	10605	20,8	358	0,7	51063
Zvenyhorodskyi	80000	100	0	0	0	0	80000
Zaslavskyi	468100	99,7	1500	0,3	0	0	469600
Cherkaskyi	2153220	99,6	0	0	9170	0,4	2162390
Chyhyrnytskyi	556000	98,2	0	0	10100	1,8	566100
Lypovetskyi	38250	91,4	0	0	3580	8,6	41830
Tarashchanskyi	66275	88,5	0	0	8650	11,5	74925
Right-Bank Ukraine	4437522	54,1	1582250	19,3	2184615	26,6	8204387

products, 33,6% from the processing of animal products, 40,3% from the processing of mineral raw materials.

Thus, the farms of the territories included in macrogroups A, C, E, for the most part were tended to a certain industrial specialization, a fact in itself interesting and previously almost unknown. In the territories of macrogroup B, the complex nature of the processing industry does not allow us to speak of any distinct specialization. In the areas of macrogroup D, the owners of the estates tried to combine the advantages of both branches of industrial processing of agricultural products, based on favorable natural conditions. This determines the intermediate position of this macrogroup in our classification between clusters with specialized and non-specialized farms.

In conclusion, we will try to determine the market orientation of an industrial specializations and their economic potential. To do this, we

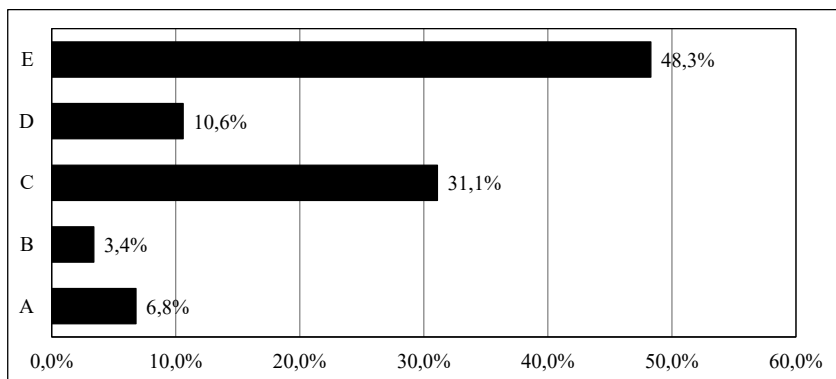

Figure 3. The share industrial profit of districts' cluster groups from the total industry profit in the Right-Bank Ukraine (1845–1847)

compare two diagrams based on the same data (Table 1), but on different indicators.

In the first case (Figure 3) the share of industrial profit of cluster groups from the total industrial profit of the Right-Bank Ukraine was used. The most market-oriented are group E farms, which were specialized in processing crop products. The second place takes group C (the Kyiv district), which was specialized in mineral processing, as well as metalworking and mechanical engineering in Kyiv city. The third position is occupied by groups D and A, which specialized in the industrial processing of livestock products, sometimes in combination with the processing of crop products (group A). Finally, group B, which had sporadic links to the market, closes this series.

Another version of the analysis involves the calculation of profit from industrial activity per capita in cluster macrogroups' areas (Figure 4).

So, we clearly see a well-known trend: an industry based solely on the processing of agricultural products, especially handicrafts, will always lose out to more advanced industries. We should also keep in mind that, following the tradition of 19th-century economic statistics, we did not include in group A profits revenues from distilling, which were usually attributed to grain trade, and local sugar production will be started to flourish only in the late 50s and early 60s years of the 19th century. Otherwise, the difference in profit between groups C and E would be less significant.

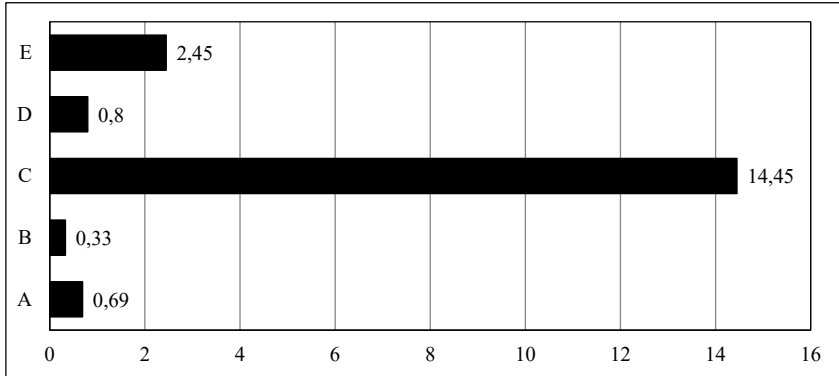

Figure 4. Industrial profit per capita of districts' cluster groups (in rubles)

Industrial processing of agricultural products (mainly of animal origin) in groups D and A shows signs of marketability, but most likely not beyond the local market. Industrial production of farms in the cluster group B is more characteristic of the feudal type of management.

Conclusions

The industrial branches of the economy were a continuation of agriculture, since they often engaged in the processing of crop and livestock products, and a significant number of the factories themselves were in the estates and based on the work of dependent peasants. The locomotive of the industrial processing of crop production in the middle of the 19-th century there was sugar factoring. In the Kyiv province the cost of a sugar plant amounted to 85-145 thousand rubles and all sugar factories were valued at 3172000 rubles. They produced almost 277 thousand poods of sugar over the season, making owners 418 thousand rubles net profit. Other products of industrial processing of crop production were significantly lower than sugar in value, but the gross output of this industry in 1845–1848 amounted to 4738600 rubles, or 57,8% of the Right-Bank Ukraine industrial production. Industrial processing of livestock products was best represented by weaving factories. In 1853, at a total of 128 enterprises, a woolen cloth worth 1370000 rubles was made. An important role was

played by the manufacture of leather. These enterprises demonstrated an annual output of 700 thousand rubles. The annual production of animal fat, greasy candles, soap and wax was estimated at about 500 thousand rubles. The gross output of livestock processing enterprises on the Right Bank was approaching 1582250 rubles. Other types of industry (metallurgy and metal processing, manufacturing of bricks and other building and decoration materials, faience and porcelain manufactories, glass mills, etc.) at the end of the 1840s had an annual output of 2184600 rubles. The total industrial production of the Right Bank Ukraine at the end of the 1840s was approaching 8204380 rubles (54,1% of the processing of crop products, 26,6% of mineral raw materials, 19,3% of animal products). Of these, 78,1% belonged to the Kyiv province, 13,4% to the Volyn and only 8,4% to the Podillia. The use of various groups of sources, primarily descriptive and statistical, allowed us not only to get acquainted with the development of industry of the Right-Bank Ukraine in the middle of the 19-th century, but to propose for the first time a statistical model of this phenomenon. We consider this analytical construction as a tool for assessing trends and levels of local production through intra-regional specialization and market relations. The macrogroup A (7 districts) received 85,8% of industrial revenues from the processing of livestock products. Macrogroup E (14 districts) was characterized by in-depth specialization in the plant origin products processing, from which 96,7% of industrial profits were received. Macrogroup C (the Kyiv district) 76,5% of industrial profits were obtained from the processing raw materials of mineral origin. Macrogroup D (8 districts) demonstrated balance of the processing industry and revenues from it – 48,5% of crop products and 44,5% of livestock products. Macrogroup B (6 districts) did not have a narrow production specialization: 26,1% of industrial profits came from processing of plant products, 33,6% from processing of livestock products, 40,3% of industrial profits from processing of minerals. The production of groups C and E showed the greatest market orientation, groups A and D met the needs of the surrounding areas, the organization of production in the estates of the group B areas was more reminiscent of the feudal.

References:

1. Andreyev Ye. N. (1862). Sveklosakhnaya promyshlennost [The sugar industry]. *Obzor razlichnykh otrasley manufakturnoy promyshlennosti Rossii*. T. I. [Review of various branches of the manufactory industry in Russia. Vol. I]. S.-Peterburg: v tip. I. Ottimbo, pp. 3–143. (in Russian)
2. Voyenno-statisticheskoye obozreniye Rossiyskoy imperii. Izdavayemoye po Vysochayshemu povelениyu pri 1-m Departamente Generalnogo shtaba. Po rekognostsirovkam i materialam, sobrannym na meste, sostavlyal Generalnogo shtaba kapitan Men'kov (1848). T. X, Ch. 1. Kiyevskaya guberniya [Military Statistical Review of the Russian Empire. Published by the Highest Command under the 1st Department of the General Staff. According to the reconnaissance and materials collected on the spot, the General Staff Captain Menkov composed. Vol. X, pt. 1. Kyiv province]. S.-Peterburg: v tip. Departamenta General'nogo shtaba. (in Russian)
3. Voyenno-statisticheskoye obozreniye Rossiyskoy imperii. Izdava-yemoye po Vysochayshemu povelениyu pri 1-m Departamente Generalnogo shtaba. Po rekognostsirovkam i materialam, sobrannym na meste, sostavlyal Generalnogo shtaba kapitan Tveritinov (1849). T. X, Ch. 2. Podolskaya guberniya [Military Statistical Review of the Russian Empire. Published by the Highest Command under the 1st Department of the General Staff. According to reconnaissance and materials collected on the spot, the General Staff Captain Tveritinov composed. Vol. X, pt. 2. Podillia province]. S.-Peterburg: v tip. Departamenta General'nogo shtaba. (in Russian)
4. Voyenno-statisticheskoye obozreniye Rossiyskoy imperii. Izda-vayemoye po Vysochayshemu povelениyu pri 1-m Departamente Gene-ral'nogo shtaba. Po rekognostsirovkam i materialam, sobrannym na meste, sostavlyal General'nogo shtaba shtabs-kapitan Fritche (1850). T. X, Ch. 3. Volynskaya guberniya [Military Statistical Review of the Russian Empire. Published by the High Command at the 1st Department of the General Staff. Based on reconnaissance and materials collected on the spot, the General Staff Captain Fritsche composed. Vol. X, pt. 3. Volyn province]. S.-Peterburg: v tip. Departamenta General'nogo shtaba. (in Russian)
5. Hordunovskiy O. M. (2000). Rozvytok promyslovoho vyrobnytstva u pomishchyt's'kykh gospodarstvakh Pravoberezhnoii Ukrainy pershoi polovyny XIX st. [The development of industrial production in the landlords of Right-Bank Ukraine in the first half of the nineteenth century]. *Ukrainskyi istorychnyi zhurnal*, no. 1, pp. 61–71. (in Ukrainian)
6. Hurzhii I. O. (1954). *Rozvytok tovarnoho vyrobnytstva i torhivli na Ukrayini (z kintsia XVIII st. do 1861 roku)* [Development of commodity production and trade in Ukraine (from the late eighteenth century to 1861)]. Kyiv: Derzhavne vydavnytstvo politychnoi literatury URSR. (in Ukrainian)
7. Devyat' guberniy Zapadno-russkogo kraya v topograficheskom, geog-nosticheskom, statisticheskom, ekonomicheskom, etnograficheskom i is-toricheskom otnosheniyakh N. Stolpyanskogo (1866) [Nine provinces of the West Russian Region in topographic, geognostic, statistical, economic, ethnographic and historical relations N. Stolpyansky]. S.-Peterburg: v tip. Gogenfel'dena i Ko. (in Russian)
8. Korsak A. (1865). Vinokureniye [Distillery]. *Obzor razlichnykh otrasley manufak-turnoy promyshlennosti Rossii*. T. III [Review of various branches of

the manufactory industry in Russia]. Vol. III. S.-Peterburg: v tip. N. Maykova, pp. 215–515. (in Russian)

9. Krepostnoye naseleniye v Rossii po 10-y narodnoy perepisi: statisticheskoye issledovaniye A. Troynitskogo (1861) [The serf population in Russia according to the 10th national census: a statistical study by A. Troynitskiy]. S.-Peterburg: v tip. Karla Vul'fa. (in Russian)

10. Materialy i issledovaniya Volynskoy gubernii v statisticheskom, etnograficheskom, sel'skokhozyaystvennom i drugikh otnosheniyakh A. Bratchikova (1868) [Materials and research of the Volyn province in statistical, ethnographic, agricultural and other respects A. Bratchikova]. Vyp. 1. Zhitomir: v tip. Gubernskogo pravleniya. (in Russian)

11. Nesterenko O. O. (1959). *Rozvytok promyslovosti na Ukrayini*. Ch. I. *Remeslo i manufaktura* [Industry development in Ukraine. Ch. I. Crafts and manufactories]. Kyiv: Vyd-vo AN URSR. (in Ukrainian)

12. Ocherk manufakturno-promyshlennykh sil Yevropeyskoy Rossii, sluzhashchiy tekstom promyshlennoy karty, v dvukh chastyakh, sostavlennyy Pavlom Kryukovym (1853) [Essay on manufacturing and industrial forces of European Russia, which serves as the text of the industrial map, in two parts, compiled by Paul Kryukov]. S.-Peterburg: v tip. Departamenta vneshney trgovli. (in Russian)

13. Pokhlebkina V. V. (1991). *Istoriya vodki (IX–XX vv.)* [History of Vodka (IX – XX cen.)]. Moscow: Inter-Verso. (in Russian)

14. Rossiyskaya statistika, Imperatorskogo Sanktpeterburg-skogo universiteta zaslužhennogo professora, deystvitelnogo statskogo sovetnika i kavalera Ye. Zyablovskogo (1842) [Russian statistics, Imperial University of St. Petersburg, Professor Emeritus, Actual State Counselor and Chevalier E. Zyablovsky]. S.-Peterburg: v tip. II'i Glazu-nova i Ko. (in Russian)

15. Statisticheskiye ocherki Rossii. Sochineniye Konstantina Arsen'yeva (1848). V 2-kh chastyakh [Statistical essays of Russia. Composition by Konstantin Arsenyev. In 2 parts]. S.-Peterburg: v tip. Imeratorskoy Akademii nauk. (in Russian)

16. Statisticheskiye svedeniya o manufakturnoy promyshlennosti v Rossii A. Semenova (1857) [Statistical information about the manufacturing industry in Russia A. Semenova]. S.-Peterburg: v tip. I.I. Glazunova i Komp. (in Russian)

17. Statisticheskij spravochnik po Yugu Rossii (1910) [Statistical Handbook of the South of Russia]. Poltava: Elektricheskaya tipolit. preyem. «I.A. Dokhman». (in Russian)

18. Statisticheskoye opisaniye Kiyevskoy gubernii, izdannoye taynym sovetnikom, senatorom Ivanom Fundukleyem. Ch. 2. (1852) [Statistical description of the Kiev province, published by Privy Councilor, Senator Ivan Fundukley. Pt. 2]. S.-Peterburg: v tip. Ministerstva vnutrennikh del. (in Russian)

19. Statisticheskoye opisaniye Kiyevskoy gubernii, izdannoye taynym sovetnikom, senatorom Ivanom Fundukleyem. Ch. 3. (1852) [Statistical description of the Kiev province, published by Privy Councilor, Senator Ivan Fundukley]. S.-Peterburg: v tip. Ministerstva vnutrennikh del. (in Russian)

20. Khozyaystvenno-statisticheskij atlas Yevropeyskoy Rossii. Izdan pri Departamente sel'skogo khozyaystva Ministerstva gosudarstvennykh imushchestv; sost. K.S. Veselovskiy (1857). Izd. 3-ye, ispr. i dop. [Economic and statistical atlas of European Russia. Published under the Department of Agriculture of the Ministry of State Property; comp. K.S. Veselovsky. Ed. 3rd, rev. and additional]. S.-Peterburg. (in Russian)

**SCIENTIFIC RATIONALITY IN AN EDUCATIONAL CONTEXT:
HISTORICAL AND PHILOSOPHICAL ANALYSIS**

Zorislav Makarov¹

Diana Bohatyrychuk²

DOI: <https://doi.org/10.30525/978-9934-26-193-0-20>

Abstract. The research paper studies the phenomenon of scientific rationality in historical and ideological contexts in order to determine the relationship between its internal scientific standards and educational projections. On the basis of historical-genetic and comparative-historical methods the paper considers the principles of classical science for the period of its formation in the XVII–XVIII centuries as those that defined the worldview possibilities and topics of cognitive theory until recently. The name of this period in the European history refers to radical changes in the social structure, the reallocation of conventional social institutions and the establishment of new ones. In particular, in the XVII–XVIII centuries the foundations of classical science are laid down in terms of its relationship with technology and the leading role in the civilization development. Reflection of theoretical problems (improvement of cognition methods, fundamental worldview development) and applied tasks (creation of new experimental tools, means of calculation) that accompanied those processes, was reflected in the philosophical thought of that time and subsequent works. Despite the known differences between the current and retrospective views of modern European and contemporary authors, at present time there is a common mechanistic denominator of the mutual impact of natural-scientific and philosophical rationality, which had been developed at that time. As we go to the analysis of modern science we weigh the alternatives of its substantiation, bring to light the changes in the field of philosophy of science caused by the historical and hermeneutic approach, and the reasons for the introduction of value characteristics to modern scientific rationality. The basic historical forms of worldview orientation, relevant educational paradigms, their content-

¹ PhD of Philosophy, Senior Lecturer at Department History of Ukraine and Philosophy, Vinnytsia National Agrarian University, Ukraine
² Student of the Vinnytsia National Agrarian University, Ukraine

related tendency and humanistic possibilities in terms of creative personality development are reconstructed over the course of representing the modern attitude to science and its rationality. We have defined the axiological bases of modern public opinion about science as one that moves only financial progress, and compared the sources and possibilities of humanism.

1. Introduction

Scientific rationality research is stimulated by both *external* social and *internal* academic relevance. The first one consists in the ambivalent attitude of modern Western civilization to scientific *knowledge*: if its “fruits” are consumed as quickly as possible, then the “light” emitted by it is often regarded as “cold”. The well-known standards of objectivity, rationality, and methodicalness do not arouse former admiration and respectful imitation in daily activities and spiritual life. Against the background of the New Age – the mass revival and activation of religious and mythological consciousness, increasing interest in archetypal structures, paranormal phenomena and extrascientific knowledge [26, p. 265–286] – the latest social and humanitarian emergencies (human global problems, remoteness of personal origin, consciousness manipulation, human-made disasters, etc.) are every so often considered as implicit consequences of scientific rationality.

Long-term criticism of ordinary empirical justification as a criterion of scientific rationality in the science itself and its philosophical reflection, leads, in the end, to a change in *the idea* of human mind in general – from *instrumental*, reducing it to a formal-logical apparatus, to *culturological and anthropological*, which provide the strong connection between cognitive procedures and social and individual mental context. Since modern generation of scientists as “children of their time” follow these guidelines, and on the other hand must be involved into the common history-making relay of ideas and methods of their field, there is an urgent need to conceptualize historical forms of scientific rationality and possible changes in its content. This topic is quite developed in the well-known works by P. Feyerabend [16], V. Ilyin [5], A. Ogurtsov [9], V. Stepin [14], V. Shvyrev [19] etc. especially in terms of definitions, classifications, criteria, historical contexts, the relationship of its scientific and philosophical aspects. However, the *role* of scientific rationality in the cultural heritage and communication of scientific and educational institutions remains poorly clarified. Despite

major works by I. Chernikova [18], I.G. Fomicheva [17], J.S. Johnston [27], A.G. Holmes [28], J. Miller [33], T. Nichols [35], C.H. Patterson [36], M.I. Romanenko [11], T.A. Rubantsova [12], S.B. Shapiro [38], I.H. Utyuzh [15] devoted to the role of scientific rationality and humanistic traditions in the organization of educational approaches, its spiritual potential is far from practical implementation.

Thus, there is a goal to reconsider the place of science with its professional way of thinking in human civilization and to discover how it is refracted in the minds of its contemporaries. In particular, in order to check the pragmatic status of science as a specific nature of the post-industrial present or as an echo of the industrial past, it is necessary to find out the characteristics of classical scientific rationality in the works of modern philosophers (F. Bacon, G. Galilei, R. Decartes, J. Locke, G.W. Leibniz, I. Newton) and their modern interpreters (P. Gaydenko, L. Kosareva, R. Merton, S. Toulmin, S. Shapin etc.). In order to check whether educational conditions are ambivalent in promoting both instrumental-pragmatic and spiritual-value attitude to science, it is necessary to analyze the educational *paradigms* of the industrial and post-industrial era in the capacity of translators of relevant examples of scientific rationality and exponents of cultural-historical ways of human orientation in the world. At the same time, differences in the subject content, means of its expression and intentions of the authors require the use of *hermeneutics*, which reveals the meaning of original texts by means of translations, comments, life context and cultural resonance of their authors.

2. Formation of a classical model of rationality

Reasoning regarding rationality are very complicated by a mixture of terminological traditions: the most general *meaning* of “reasonableness” in some cases refers to the denotation of actual “human”, in other cases it is opposed to the “spiritual”. In science, however, “rationality” is used not only on the worldview, but also on the general scientific level, identifying both with the philosophical reflexivity, and with the features of logical and methodological organization of scientific knowledge. In their turn, the humanity or remoteness of scientific rationality from human beings can be a historically differentiated issue: for example, medieval scholasticism is often called formal and soulless, humanist studies – the inspirers of human victory, etc. However, the educational image of science, firmly rooted by a

modern public opinion, consists of the principles, terms and personalities of *classical science*, which traces its origins to Modern times.

For example, classic of philosophy of science St. Toulmin [40] described this connection in “three *axioms* of the traditions of the XVII century”, which for a long time began to define the course of epistemology despite the skepticism and criticism of individual characters such as B. Pascal, S. Kierkegaard or F. Nietzsche.

Firstly, this refers to the stability of natural ontology, which provides a basis for stable and universal principles of its understanding in the process of scientific research and domination over it in the practice of economy management. This “axiom” was based on the biblical statement defining a clear plan for the Creation of the world and the dominant role of human beings on the earth. F. Bacon, one of the founders of modern European science, understands a human being as a full-fledged master in the workshop of nature, full of its own laws [2, p. 182]. Moreover, although over recent centuries all the components of this “workshop” have turned into historical variables, their perception is also presented as objective representations, the subjective impurities (“idols”) of which can only blur everything.

Secondly, the inertia of *matter*, which provided in it not more than mechanical *activity* (contact, push, exchange of movements) and hence the concentration of all rational activity in the spirit – in the course of the Creation or knowledge of material nature. On the one hand, this “axiom” made it possible for G. Galilei to bring physics to the standards of geometry for the first time [4], and on the other hand, it implies an objectivist *criterion* of empirical justification (“verification”) of scientific propositions, which has not yet been shaken by dynamic models of matter or neurophysiological models of higher mental activity.

Thirdly, the geometric *standard*, which, according to the Platonic model, protects knowledge from skepticism by its own value neutrality. According to Descartes, “of all the sciences so far discovered, arithmetic and geometry alone are as we said above free from any taint of falsity or uncertainty <...> they alone are concerned with an object so pure and simple that they make no assumptions that experience might render uncertain, they consist entirely in deducing conclusions by means of rational arguments” [25, p. 12].

In order to understand the impact of these “axioms”, one must know that they resulted from solving the classical problem of the reproduction of

metaposition, which originates in the Christian conception of the Absolute Mind. It can be recognized in R. Descartes's cogito, I. Kant's apriorism and Fichtean transcendental subjectivity. In order to change the idea of the unity of man and the world in the God creatable, philosophical thought has developed the idea of the unity of man and the world in the god acting expediently. Later, the guarantee of this unity was transferred from the God to the absolute mind in the form of the world Absolute or natural integrity, in order to derive the human mind from them with all its cognitive abilities.

The main possible options of this position, developed by modern European philosophy, are similar to the replacement of the theological Absolute Mind by scientific intelligence with its preconditions – axiomatic self-evident and self-sufficient rules of consistent reasoning, though burdened with “idols” of one-sided, in particular outdated or distorted values. That kind of methodical organization of thinking itself in addition to nature and society seemed to be the highest form of *power*, where a human being not only took upon herself/himself the creative abilities of the Absolute to meet and develop their needs, but also found guarantees of their freedom.

Once the formal apparatus of scholasticism created a precedent for mastering spiritual mysticism with its spontaneity and immediacy, mathematics took up the baton of rational reconstructions of transcendental experience from logic. Its novelty consisted of meaningful *theories* that made it possible to deduce formally and unambiguously any complex (complicated) knowledge from their components like from the “atoms”. In this regard, Galileo's interpretation of the theory as a simulation of the infinity of divine *truths* by extremalizing their finite symptoms in the form of self-identical mathematical idealizations gained fame: “the truth, knowledge of which is given to us by mathematical proofs, the truth which is known to divine wisdom; however <...> our way consists in reasoning and transition from a conclusion to a conclusion, while His way is the simple intuition <...>” [31, p. 129].

In this way, being only a kind of *rational*, leading its genealogy from the ancient cultural archetypes, the knowledge, cultivated by the modern European mathematization of science have become the notion (ratio, mens) that involves the articulating and ordering abilities of the mind. According to its mathematical model, scientists and philosophers not only compare the accuracy and provability of knowledge of the laws of nature, but also establish the comparability of the content of scientific ideas, their

selection and accumulation. “An infinite world, here a world of idealities, is conceived, not as one whose objects become accessible to our knowledge singly, imperfectly, and as it were accidentally, but as one which is attained by a rational, systematically coherent method. In the infinite progression of this method, every object is ultimately attained according to its full being-in-itself <...> nature itself becomes – to express it in a modern way – a mathematical manifold” [30, p. 22, 23].

Mathematics could be represented as a new guarantor of objective cognition, under the condition of rearrangement of the nomenclature of “higher abilities” of the human Self. Thus, the Cartesian model of personality, for the first time, provided a distinction between the objectified *content* of consciousness and its “secondary *qualities*”, which are entirely derived from the perceptual states and their experience. The mind, capable of exploring “things in and of themselves” and acquiring knowledge regardless of will, intentions, faith, intuition and other subjective presentations acquires the status of personal ability of *objective* representation in R. Descartes’ metaphysics, while *objectivity* was identified with subjective transcendental involvement as a means, purpose, instrument, gesture, or statement in the logical imperative of scholasticism.

Despite all the references to human nature, common sense and progressive aspirations, a subject with the said consciousness is not defined in the space and time of not only cultural and historical, but also physical existence. Thus, in order to become a subject of scientific knowledge, a person loses her individual dimension. However, precisely this mind, designed to reflection over the subjective aspect of cognition and corresponding to the further hegemony of natural-scientific problematics, experimental and mathematical methods, proved to be a successful form of interconnection of the concepts of freedom of thought and responsibility for its content. Due to this, scientific rationality has long been established as a link between European values such as freedom and democracy.

Along with a clear explication of methods and demarcation of the research field, the given “axioms” (criteria) of classical scientific rationality provided such a successful progress of science that presented a model of social change (Enlightenment Project) and ensured the formation of independent social institute of science. However, beyond the rational description there are objects that can only be described in qualitative terms,

first of all, the phenomena of spiritual substance, if their properties were not studied by the means of formalization of those times. Accordingly, careful attention of some researcher to such objects positioned him as a representative of *extra* scientific fields or even as an *anti-scientist*.

3. Internal and external problems of classical rationality

Ideological reasoning of the *anti-scientific* position took place in *post-Enlightenment irrationalist philosophy*, which started with the opposition of the mind to will, love, instincts, intuition as more fundamental phenomena, and ended up with the limitation of the universalism of scientific rationality: the mind is wider than the science, because unscientific forms of spiritual activity (myth, magic, spiritual traditions, arts) are able to perform not only their own specific but also socio-cultural functions peculiar to science. “It takes billions of dollars, thousands of highly skilled professionals, years of hard work in order to enable a few tongue-tied and rather limited contemporaries to make a steady leap where no person with sound mind would want to go – to the empty, airless world of the burning hot stones. However, the mystics, using only their own consciousness, traveled through the heavenly spheres and contemplated God in all its glory, which gave them the strength to live and enlighten their followers” [16, p. 497–498]. Therefore, we can observe the introduction of a general cultural tendency of complementarity of scientific and unscientific knowledge.

The counter-movement on the part of science was initiated by the *de-absolutization* of G. Saccheri’s, J.H. Lambert’s, C.F. Gauss’s etc. Euclidean system for building knowledge, which found out that attempts of complete explication of the “source knowledge” (principium ratio) used in the reflexive act turn into paradoxes [29, p. 15–16]. In nonclassical science the said “crisis of *basic principles*” was stimulated by the development of ever more “obstinate” objects: the phenomena of spiritual substance (which in the XIX century received its own scientific residence as the humanities) were followed by quantum mechanical, cosmological and, finally, complex natural systems with feedback links with the environment and alternative development *trajectories* that are not subject to removal from the “initial conditions” of observation. “Nonlinear” objects of that kind (for example, ecological) turned upside down scientific-rationalist objectivism – the position of an external observer, whose cognitive apparatus had to maintain

isomorphism with any modifications of the studied natural processes, and their course, in its turn, – to maintain independence from the cognitive procedures applied. The opposite principle of subjectivity requires taking into consideration the *knower's* activity with its methodological and value preferences and replace cognitive tasks by evaluative ones – in the situations of methodological or financial planning of research, selection of models originated from the fundamental theory, etc.

In the concepts of historical types of V.S. Stepin's and V.V. Illyin's scientific rationality, this transformation of principles acquires a schematic form of rationalization circle revolutionary expansion – from the cognitive object (classic) to its means (non-classic) and goals and values (post-non-classic or neo-non-classical) [14, p. 619–636]. In this way the history of scientific rationality is reconstructed as a revolutionary transition from the epistemological principle (“knowledge is the goal”) to the *anthropic* one (“knowledge is a means”), which introduces the need for universal justification of knowledge into the goals and values of knowledge [5].

Given that they have the revolutionary name, these changes in scientific rationality are fully covered by the original archetype of rationality – the ancient idea of “τεχνη” as an artificial reproduction or transformation of reality, which happened to have its continuation in Christian verbalist creationism. In influential Aristotelian epistemology, τεχνη is defined as a special step of knowledge, which is based on practice (“wisdom of the head and hands”), but differs from handicrafts by clarifying the “general” (ἐπιστήμη) and “reasons” (ἀρχαί). If the objectivity of the “general”, which is opposed to the opinions, can be unambiguously determined by means of the rules of logic (“Organon”), then the Aristotelian “reasons” constitute a temporary or subjective component of τεχνη. It follows from here that its relative definition and artistic dependence on the chosen goals, means, results and the degree of their complementarity: “rationality can be considered at three main levels of its own operation: as mental activity performance that uses conscious forms in driving towards the goal, methods, logical tools, categories etc.; as cultural existence performance and human spiritual and practical activity, when rationality is attributed not only to the processes of the cognitive plan, but also to the forms of existence of knowledge itself in culture; and finally, rationality is used by the forms of human activity itself, established in the form of various types of technologies, social and vital structures” [6, p. 7].

Thus, the initial relativity of the idea *τεχνη* determines the philosophical scale of the rationality issue and the immanent incompleteness of its solution, which remains invisible in the times of firmly established values.

4. Reason and reason in the structure of modern scientific rationality

As opposed to the ontological concepts of the classics, at present time rationality is called as the property of creative activity (cognitive and practical) to bring reality to its human-dimension modes on a conscious level. Although the relevant fragments of reality are usually provided with this property in the secondary plan – the “first” or “second” nature of ecology, biotechnology, genetic engineering, biomedical devices, artificial intelligence, etc. – the original human-dimension as a theoretical correspondence to a certain context of the Subject contains a distinction between objective (one that determines the *means* of activity) and subjective (one that determines the *goals* of activity) components. In this regard, certain means and goals are as before identified to be organically interconnected by means of a sequence of actions. If some successful sequence of action is degraded, the correspondence of means and goals is established by a complex analytical way: “<...> “intra-theoretical” and, more wider, scientific rationality, represented in a set of strategies and methods of construction of the idealized image of reality, precedes the studied *objects*, and the latter ones are created in the process of rational activity” [1, p. 66].

The last-mentioned thesis points to the inevitability of the reflexive component of rationality, which in the isolated mode constitutes, as a matter of fact, “mind” as opposed to the “reason” of the European philosophical tradition. If the mind performs (re-produces) analysis, abstraction, normalization, the mind reflects over this rationalization, correlating in due from the processes of induction of sensations and deduction of concepts with the normative structure of cognition. The latter represents traditionally human – finite and embodied – reproduction of infinite prototypes and intuitions of the divine mind. “<...> The universe dissolved into an infinite multiplicity of infinitely different movements, each circling around its own centre, and all held together both by their relationship to a common cause and by their participation in one and the same universal order. The same is true of spiritual being” [23, p. 28].

There is a hidden paradox in this: personification of the transcendent in the normative cognition structure, in order to avoid naive anthropomorphism,

requires dismissal from the *transcendent* in that form in which it is imagined by a human being in alternative goal-setting. It is known that Nicholas of Cusa solved this contradiction by means of mathematical symbolization of *categories*, turning them into obviously incomprehensible for understanding, but free from specific content. After a series of attempts from R. Descartes to B. Russell to build the normative structure of cognition to the rules of calculating the reliability of deductive inference, this dismissal of categories from the content was recognized as the main function of the symbol to attract new experience, to develop [3]. “The number in the Platonic-Pythagorean experience was therefore “*everything*” that encrypted, or digitized, the secret meaning of “*everything*” in itself, in R. Descartes it is no longer “*everything*”, but can become “*everything*”, because purified to emptiness, now it is a pure *tool* applicable to anything by means of “rules for operation” [13, p. 373].

At a later time, postmodernism will qualify this structure of cognition as a “discourse of representation” – a set of measures imitating the elevation of particular events and their semantic content to the original “transcendental significatum” to cause its presence (re-presentation). Since the extent of this transition is eventually determined by the *categorization* as the organization of content into the predicative structures, categories (“the concepts of mind”) generated under these conditions – such as “existence” or “idea” – according to G. Deleuze, have no certainty and are not even defined as “an unlimited singular plurality of concept identities”. However it is this non-identity (*sans fond*) makes it possible for them to reduce the never-ending opportunities of representations (*difference*) to a self-sufficient mind that replaces the transcendent Logos [24].

Under worldly conditions the reproduction of the ideas of the divine mind is limited to the *reproduction of the mode of action* of Providence when taking control over the flow of things, for this purpose methodological principles (identity and contradiction, continuity, sufficient basis, universal relationship), methods and normative structure of cognition are designated [32]. This methodology of human comprehension of the transcendent acquires the status of universal metaphysics of the modern worldview by its ability with the necessity to combine unique apriori and any experiential preconditions. It is obvious that in the course of this reflection a certain invariant of transforming activity can be established, its universal scheme, reasonable for different

types of activity, when studying various types of objects. In this case, we are talking about “methodological” (“wisdom of the head”) rationality contrary to “operational” (“wisdom of the head and hands”), having an empirical or special nature [19]. But the current problem involves the need to supplement the idea of rationality as a sequence of patterns of activity with certain directions of possible and the framework of the impossible, proportionate to human life in terms of its relationship to himself and the world they created.

Insofar as scientific activity has long ceased to be commensurate with the abilities of some *scientists*, their personal motivation and subject-cognitive activity are equally mediated by a whole range of professional norms ensuring the differentiation of labour and generational bridge. Therefore, the sense-bearing and life orientation of rationality promised to detect some regularities useful for improving the predictions or argumentation only on a generalized scale of entire scientific societies. Thus, there appeared the models of *historical* development of knowledge in the practice of philosophical reflection on science (K. Popper, T. Kuhn, M. Foucault, G. Holton etc.), these models covered external factors and revolutionary overthrows in the basics of science – the scientific picture of the world, the style of thinking, and the ideals of rationality. On the other hand, what is the measure of this appearance and revolutionary character: should we take into account any goals and values *or* only those that have been mastered by socio-humanitarian science in subject, reproducible, verifiable knowledge as a buffer zone between science and irrational *non-scientific* fields (myth, magic, arts, politics, spiritual traditions)?

5. Rational basis of educational paradigms

The history of science certifies that these questions are not new: the Romantics (F. Schleiermacher, F.-R. de Chateaubriand etc.) at the turn of the XVIII–XIX centuries denied the Enlightenment course on the establishment of scientific mind as the universal driving force of history. To be more precise, it referred to the subordination of the entire discursive knowledge to the mythological origins of *tradition*, which had to provide the disclosure of the creative potential of human existence, individual *self-determination* within the context of the meaning of his life, and so on [9, p. 340]. According to phenomenology, mathematical science, using the method of idealized entities, contributed to the scientification of the “life world” of cultural values, which resulted in the suppression of the

subject's creative ability and the whole European culture to a symptomatic disassociation from reality, escalating again the Cartesian "doubt". At the same time, to eliminate this longing for absolute truth, it is suggested to *eliminate* the problem of the identity of existence and thinking and the "understanding" perception of a scientific object – as a text without a transcendent referent, with open alternatives to reasoning.

The elimination of the dichotomy of subject and object in the structure of experience inevitably introduces the *event conditions* of thought into the implementation of the subject essence, so that the predicative structure of the categories used is determined by the linguistic and semantic context. It is these subjective conditions of thought that are absolutized in the philosophy of irrationalism of the XIX century, having the aim of set an *individual* free from the dictates of Mind, winning back her ability to look beyond the discursive forms of cognition; especially since cognitive goals are considered herein as derivatives of thirst for power, sexuality and the suppression of thoughts about the inevitability of death.

Subsequently, this emancipation meant the opening of the theory of rationality as a formalized system. The correlation of various elements of human spiritual experience, the implementation of "existentially motivated life-spiritual synthesis" within the context of consciousness served as one of the incentives for the development of a new concept – *open* rationality, where the final basics (as opposed to "initial" basics of analytical method) remain probabilistic. Thus, the absolutist idea of complete removal of experience by relevant theoretical means was denied, because they do not have a place for the unique conditions of existence and will peculiar to the socio-humanitarian object. This refers to the opposition, well-known from the time of S. Kierkegaard, of rational general and irrational individual on the basis of the ability to self-determination. The mind is transformed from the master of reality into a guiding principle of cognition, the tradition and logic of which are established to the extent of interaction between the participants of knowledge and are developed in the pragmatic context of the task chosen [16]. It means the loss of guarantees that logical and ontological determinism are isomorphic: the world does not have to have a subject-predicate structure, consist of substances, be simple and mathematical.

Therefore, modern European irrationalism is notable not so much for the internal unprofitability of mystification as for the object prediction, first

and foremost the objects of particular practice and communication, rather than cognition – the features of uncertainty and backwardness. Moreover, if rationality is defined in the traditional epistemological aspect as a degree of conformity of discursive expression of knowledge to the existing forms of thinking, then the boundary between rational and irrational should be considered relative, having variable intermediate forms. As the criteria of scientific knowledge and their generalization in the forms of scientific rationality become mobile, derived to a great extent from what is now mastered by theoretical science, there is an argument from irrationalism about the permanent underdevelopment of fundamentally new phenomena. They not only supplement the potential of scientific knowledge, conflicting with reality and truth as these notions are recognized in current forms of thinking, but in equal measure – the arsenal of scientific means, offering new goals and values, in the long run of which current science and rationality seem to be insufficient.

Therefore, the epistemological strategies of the XX century, especially positivist models of scientific knowledge, appeared to be more focused on relative *criteria* of rationality: systematic, semantic or methodological internal coherence in combination with the principles of fallibilism and historical relativism – as the form of objective (discursive, paradigmatic, epistemic) reduction of rationality standards. Thus, the Marxist methodology in the management of cognitive activity provided to use a reflexive *level* in addition to the subject one, which should establish the spiritual and practical prerequisites for the formation and development of categories and epistemology in general. At present time, such values may have totally different sources with unexpected sociocultural and existential meanings, not necessarily related to positive transcendence of scientific reason. For example, the philosophy of postmodernism provides passing all the boundaries outlined by the great ideals (“metanarratives”) of the industrial age in order to ensure free cultivation and unlimited development of human subjectivity. The search for truth, especially according to the model of classical scientific rationality, loses the status of the most important tendency among the inexhaustible variety of its dimensions.

In this respect the glorification of the sphere of the unconscious (inclinations, instincts, intuition, faith, tacit experience) does not exclude the humanistic tradition, causing changes in social and cognitive situations, in particular, the review of educational *paradigms*. Although the latter are

detailed in a variety of expedient practices (“methodic”, “technologies”), they themselves, as well as the scientific content they broadcast, are always involved in a broader context, the basis of which (except for current worldview human images, moral values, political interests, etc.) is the way of orientation in the world. In European intellectual history, there are only three ways of this orientation – contemplative (traditional), activity (objectiv) and modern – dialogue (subjectiv) [18, p. 89–90].

The components of existence and their reflection in the consciousness of the subject appear to be identical within the context of the *contemplative* world perception, having regard to their initial proportions. Although their empirical identity is not necessarily performed, the effect of the reflection is considered to be a well-defined parameter of this existence. In the projection on the socio-cultural organization the contemplative way of orientation in the world is represented by the conventional system with the imperative-mandatory educational paradigm peculiar to it.

Activity world perception contains a cognitive *vector* of evaluative and transformative activity, directed from the subject to the *object*, into which the component of existence previously irrelevant now turns. The educational paradigm in this case is interpreted as an *activity* related to the implementation of the social order, development of an individual’s typical model, and subsequently – as a consistent projection of this model on the sphere of the object of education. It is related to the class-and-lesson system of education, frontal-reproductive acquisition of knowledge, curricula as a substantive development of the social order, universal principles of pedagogical interaction and other basic principles of the such pioneers of scientific pedagogy as J.A. Comenius, J. Locke, J. Herbart etc. [12].

The new generation of ideologists of this paradigm (M.J. Adler [20], J.S. Bruner [21] etc.) presupposes the possibility of the individual to surpass the cultural heritage acquired by him/her through fundamental scientific knowledge and, consequently, to receive distinction and social preferences. On this way, it is provided to specify educational goals in the lists of knowledge, skills and attitudes in order to be able to develop an individual academic schedule and management of self-education [22]. At the same time, the guideline for the comprehensive transfer of social goals into educational ones makes itself felt in the maximum technologicalization of the pedagogical process (tests, training, algorithms, computer programs)

up to the interpretation of the educational result as an “extended behavioral repertoire” of the individual [39].

Dialogue-based worldview, which as a matter of fact, originates from Socrates’ maieutics, in the most general form abandons the privileged intellectual position of the external observer, and apriori meaningful goals, meanings, tools of cognition and interaction as well. It corresponds to the multidimensional and decentralized socio-cultural situations of the information age, when orientation in the world is mediated by temporary circles of communication, and entering the society loses guarantees of social status and professional qualification in favor of personal *self-determination* and its progressive amendments [37, p. 360].

In the process of education this is reflected in the moral parity of the relationship between the tutor and the learner (“subject-subject education” by S.L. Rubinstein and A.N. Leontiev; “Cooperation pedagogy” by S.N. Lysenkova and V. Shatalov, Waldorf pedagogy etc.): it is not the person who fits into the educational order of society, but education fits into the *person’s* vital needs. In this way, the new requirement of its humanistic significance and naturalness regarding didactic material is rewarded with the prospect of being learned to the full extent, which seemed to be problematic under the conditions of the “educational conveyor” of the object educational paradigm [34]. However, its individual features acquire a constructive meaning only as a part of the mentioned *ability* of self-determination, and the development of the latter requires any kind of participation of a young person in the presentation of subject matters as certain components of sociocultural existence, in particular, experiencing the conflicts of their formation history and particularity detention of their own interests and beliefs. “In the same way, the purpose of education is transformed, the implementation of which involves at present time not only the learning of socio-cultural experience of mankind, but also the process of personal self-formation, his self-realization through the production of experience having a dual nature – individual and socio-cultural experience of the mankind” [10, p. 228].

Therefore, the use of the subject paradigm is possible and efficient depending on the level of initial subject and reflexive psychological training of both parties of the educational process. This particularly shows the (in)ability to work in groups (discussions, statistical modelling, laboratory projects), otherwise the educational goal of personal development is replaced by the means of professional training

and under the guise of modern forms, a conservative monologue (traditional or object) *complex* of character education is dominant, which under the conditions of mosaic post-industrial mass culture turns into nihilism in its consciousness, transferring the level of authority from tutors to mass media, and educational motivation from cognitive to pragmatic or hedonistic [8; 35]. Thus, the idea of science as a provider of educational content seems to be selective, limited by the rapid visual efficiency, which is, first, provided by its technical applications. In this form, scientific rationality falls back to the images of New Age mechanics, and the respective gaps in its humanistic significance are compensated by the reasonable irrational culture of the New Age.

The theories of nonlinear dynamical systems highly-demanded in recent times can become the ontological basis of the subjective approach in modern education. Models and concepts of synergetics, chaos theory, etc. acquire high heuristic value beyond the original physical chemistry, cybernetics and nonlinear dynamics, creating applications in both technical and socio-humanitarian fields of knowledge. Therefore, educational applications of nonlinear theories in science determine the priority of dialogic, problem-based, content-integrative and individual forms of education. In this regard a classical scheme of “the right question – the reference answer” is broken, which results in a value balance in the didactics of the logic of concepts and chaotic components. Standing together, they form a network of associations of individual experience and serve as centers for the memory organization, understanding of knowledge and individual’s practical competence [7].

6. Conclusion

Classical scientific rationality, which still often defines the “face” of science in public opinion, provides a mechanistic image of nature as a reproducible apparatus deprived of inwardness, which under the condition of accurate “geometric” description can be represented by the human mind in the form of unambiguous scientific *laws*. The latter are presented as an ambivalent tool, and the scientifically-based process of obtaining them – as one that on its own terms is deprived of humanistic significance. The review of classical scientific rationality, which became imminent under the influence of new ontology (historical and evolutionary, quantum-mechanical, non-linear objects) and the increasing measure of abstraction of its representation (non-euclidean geometries and other alternative theoretical models), found its way into the

weakening of the objectivist verifiability *criterion* of in favor of the subjectivist one, when blurring the dualism of inert matter and mind activity, when breaking the partition wall between the science of nature and science of spirit.

Modern European worldview attitudes have, to a large extent, broken through the modern image of rationality and scientific-cognitive expansion and these attitudes are compatible with humanistic values primarily by means of sociologization and historicization of scientific rationality criteria. Contrary opinions in everyday awareness are caused by the ambivalent practice of post-industrial educational paradigms or by the greater inertia of the educational institution in the translation of cultural codes. *Post*-nonclassical scientific rationality and the *post*-industrial educational paradigm have a common denominator of *duality* of discursive standards and personal immediacy, which in classical terminology were contrasted as natural rational and accidental irrational. Nowadays this *duality* is presented in the philosophy of science as humanistic *complementarity* of scientific and non-scientific, and when translating scientific achievements in education – as a *dialogics* of the subjects of education. The impossibility to remove social determination from the operation of social institutions of science and education represents on the one hand, a reason for recurrences of archaic ways of orientation in the world – mechanistic paradigm in science, monologue approaches in education – and, on the other hand, the condition of *individual's* personal level of development, while the latter happens to have creativity towards fundamental scientific knowledge and existing forms of social life in general, and by means of abovementioned – to himself.

References:

1. Belokobyl'skiy A. V. (2008). Osnovaniya i strategii ratsional'nosti moderna [Foundations and strategies of rationality of Modern]: [mon.]. Kyiv: Izd. PARAPAN. (in Russian)
2. Bacon F. (1977). O dostoinstve i preumnozhenii nauk [De dignitate et Auginentis Scientiarum]. Bacon F. The Works Trans. N.A. Fedorov. 2 ed. Moscow: Mysly, vol. 1, pp. 81–522. (in Russian)
3. Weyl H. (1989). O simvolizme matematiki i matematicheskoy fiziki [On the symbolism of mathematics and mathematical physics]. *Matematicheskoye myshleniye* [Mathematical thinking] / Trans. Yu. A. Danilov, Ed. B. V. Biryukov, A. N. Parshyn. Moscow: Mir, pp. 55–69. (in Russian)
4. Gaydenko P. P. (1997). Khristianstvo i genezis novoyevropeyskogo yest-estvoznaniya [Christianity and the genesis of modern European natural science]. *Filosofsko-religioznyye istoki nauki* [Philosophical and religious origins of science] / Ed. P.P. Gaydenko/ Moscow: MARTIS, pp. 44–87.

5. Ilyin V. V. (1993). Klassika – neklassika – neoneklassika [Classic – non-classic – neo-non-classic]. *Bulletin of MSU*, no. 2, pp. 16–34.
6. Yolon P. F., Krymskiy S. B., Parahonskiy B. V. (1989). Ratsional'nost' v nauke i kul'ture [Rationality in Science and Culture] / Ed. V. P. Ivanov. Kyiv: Naukova dumka. (in Russian)
7. Kremeniy V. G., Ilyin V. V. etc. (2014). Synerhetyka i osvita. [Synergetics and education] / Ed. V. G. Kremeniy. Kyiv: Instytut OD. (in Ukrainian)
8. Kultayeva M. (2020). Homo digitalis, dyhital'na kul'tura i dyhital'na osvita: filosofsko-antropologichni i filosofsko-osvitni rozvidky [Homo digitalis, digital culture and digital education: philosophical-anthropological and philosophical-educational explorations]. *Philosophy of education*, no. 1, pp. 8–34.
9. Ogurtsov A. P. (2011). Filosofiya nauki: Dvadsyatyy vek [Philosophy of science: twentieth Century. Concepts and problems], vol. 1. St.-Petersburg: Izd. dom "Mir". (in Russian)
10. Panfylvov O. Yu., Savchenko O. O. (2020). Paradyhmal'nyy vymir suchasnoho osvitn'oho prostoru. [The paradigmatic dimension of modern educational space]. *Bulletin of the National Law University named after Yaroslav the Wise*, no. 3(46), pp. 220–234.
11. Romanenko M. I. (2000). Osvitnya paradyhma: henezys idey ta system [Educational paradigm: genesis of ideas and systems]. Dnepropetrovsk: Promin. (in Ukrainian)
12. Rubantsova T. A. (2017). Sovremennaya paradigma obrazovaniya: traditsii i innovatsii [The modern paradigm of education: tradition and innovation]. *Philosophy of education*, vol. 1, no. 70, pp. 22–28.
13. Swassjan K. A. (2002). Stanovleniye yevropeyskoy nauki [Formation of European science]. Moskow: Evidentis. (in Russian)
14. Stepin V. S. (2003). Teoreticheskoye znaniye: struktura, istoricheskaya evolyutsiya [Theoretical knowledge: structure, historical evolution]. Moskow: Progress-Traditsiya. (in Russian)
15. Utyuzh I. H. (2012) Paradyhmal'ni zasady osvitn'oho prostoru [Paradigmatic principles of educational space]. Zaporizhzhya: Prosvita. (in Ukrainian)
16. Feyerabend P. (1986). [Science in a Free Society]. *Feyerabend P. Selected Works on the Methodology of Science* / Trans. A.L. Niliforov, Ed. I.S. Narskiy. Moscow: Progress, pp. 467–523. (in Russian)
17. Fomicheva I. G. (2004). Filosofiya obrazovaniya: nekotoryye podkhody k probleme [Philosophy of education: some approaches to the problem]. Novosibirsk: Izd-vo SO RAN. (in Russian)
18. Chernikova I. V. (2011). Filosofiya i istoriya nauki [Philosophy and history of science]. 2 ed. Tomsk: NTL. (in Russian)
19. Shvyrev V. S. (2003). Ratsional'nost' kak tsennost' kul'tury. Traditsiya i sovremennost' [Rationality as a value of culture. Tradition and modernity]. Moskow: Progress-Traditsiya. (in Russian)
20. Adler M. J. (1942) In Defense of the Philosophy of Education. *Philosophies of Education. 41st Yearbook of the National Society for the Study of Education*. Chicago: University of Chicago Press, part 1, pp. 197–249.

21. Bruner J. S. (1966) *Toward a Theory of Instruction*. Cambridge, Mass.: Belknap Press of Harvard University, 176 p.
22. Bloom B. S. (1969) *Taxonomy of Educational Objectives: The Classification of Educational Goals*. New York: Longmans, Green, 228 p.
23. Cassirer E. (2000) *The individual and the cosmos in Renaissance philosophy*. Trans. by M. Domandi. Mineola, N.Y.: Dover publications, Inc., 199 p.
24. Deleuze G. (1983) *Nietzsche and Philosophy*. New York: Columbia University Press, 256 p.
25. Descartes R. (1985) *Rules for the Directions of the Mind. The philosophical writings of Descartes, vol. I / Trans. by J. Cottingham, R. Stoothoff, D. Murdoch*. Cambridge: CUP, pp. 7–78.
26. Eco U. (2006) *A passo di gambero. Guerre calde e populismo mediatico*. Milano: Bompiani, 349 p.
27. Johnston J. S. (2019) *Problems in Philosophy of Education: A Systematic Approach* N.Y. Bloomsbury academic, 248 p.
28. Holmes A. G. (2019) *Learning Outcomes – A Good Idea, Yet with Problems and Lost Opportunities*. *Educational process*, vol. 8, issue 3, pp. 159–169.
29. Husserl E. (2001) *Logical Investigations / Trans. by J.N. Findlay*. London, New-York: Routledge, 332 p.
30. Husserl E. (1970) *The Crisis of European Sciences and Transcendental Phenomenology. An Introduction to Phenomenological Philosophy / Trans. D. Carr*. Evanston, IL: Northwestern university Press, 405 p.
31. Galilei G. *Dialogo sopra i due massimi sistemi del mondo. Le Opere di Galileo Galilei / Ristampa della edizione Nazionale in 21 vols*. Firenze: G. Barbera, 1929–1938, vol. VII. 1933. [1632], pp. 21–521.
32. Leibniz G. V. (2020) *Discourse on Metaphysics*. Trans. G. Rodriguez-Pereyra. Oxford University Press, 199 p.
33. Miller J. (2000) *Education and the Soul: Toward a Spiritual Curriculum*, NY: SUNY Press, Albany, 180 p.
34. Miller J. P. (2007) *The holistic curriculum*. Toronto: University of Toronto Press, 208 p.
35. Nichols T. (2017) *The Death of Expertise: The Campaign Against Established Knowledge and Why it Matters*. New York: Oxford University Press, 272 p.
36. Patterson C. H. (1973) *Humanistic education*. Englewood Cliffs, N.J.: Prentice-Hall, 239 p.
37. Rorty R. (1980) *Philosophy and the Mirror of Nature* Princeton: PUP, 400 p.
38. Shapiro S. B. (1986) *Survey of basic instructional value in humanistic education*. *Journal of Humanistic Education and Development*, vol. 24, issue 4, pp. 144–158.
39. Skinner B. F. (1968) *The Technology of Teaching*. New York: Appleton-Century-Crofts, 271 p.
40. Toulmin S. (1972) *Human Understanding. Volume I: The Collective Use and Evolution of Concepts*. New Jersey: Princeton University Press, 534 p.

CHAPTER «PEDAGOGICAL SCIENCES»

EDUCATION IN THE UKRAINIAN FOREST-STEPPE PROVINCES OF THE RUSSIAN EMPIRE IN THE FIRST HALF OF THE XIX CENTURY

Kostiantin Levchuk¹

DOI: <https://doi.org/10.30525/978-9934-26-193-0-21>

Abstract. This chapter is devoted to the formation of the education system in a number of Left Bank and Right Bank Ukrainian lands in the first half of the XIX century. The purpose of our study is to study the educational policy of tsarism towards ethnic, religious and social groups living in Ukraine. General scientific and historical research methods were used, including a systematic approach, the principles of objectivity and comprehensiveness, historical-genetic and synchronous methods. Statistical data published in official publications of the Russian Empire were the main source of information on public education. In particular, the “Military-Statistical Review of the Russian Empire analyzed in detail the social, economic, religious development of each province as in the mid-nineteenth century.

The historiography of the problem is analyzed. It is noted that the attention of researchers is focused on the study of certain elements of public education, the level of education of social classes, national minorities, the formation and development of higher education. Study of general features of educational policy of the state in the provinces of Forest-Steppe Ukraine remains outside the scope of scientific research and its impact on the formation of the foundations of national identity of the Ukrainian people, public struggle for equal and fair nature of all levels of education.

It was found out that the system of educational institutions was formed at the beginning of the XIX century. in the Russian Empire. It did not

¹ Doctor of Historical Sciences, Professor,
Head of the Department of History of Ukraine and Philosophy,
Vinnytsia National Agrarian University, Ukraine

guarantee the right to free and unrestricted access to education for all social groups. The tsarist struggle against the influence of the Polish aristocracy on educational processes in the provinces of the Right Bank of Ukraine strengthened the Russification policy under reactionary-conservative slogans. Education becomes an instrument of the policy of the autocracy and is aimed at protecting the existing feudal system. It is recognized that the opportunity to receive education directly depended on the social status and place of the person in the hierarchy. The vast majority of Ukrainian serfs did not have the opportunity to teach their children at all, as their education depended on the good will of the landlords and was not regulated by the state.

It is established that the development of higher education in the Forest-Steppe Ukraine during the first half of the XIX century testified to the complete dependence of the educational policy of the autocracy on the will of the autocrat. The founding of Kharkiv University took place in line with the Enlightenment traditions in 1805, spread in Europe under the influence of Napoleon's conquests. However, universities lost their self-government, freedom of teaching and became completely dependent on state funding during the reign of Nicholas I. The university administration paid considerable attention to the supervision of students and their discipline.

It is concluded that the Ukrainian intelligentsia represents the interests of the oppressed people. They focused their energy on studying the history, culture, language and customs of the people, which in turn led to the politicization of the protest and the emergence of the Ukrainian national-educational movement.

1. Introduction

The relevance of our study is that it is important to rethink educational laws in the context of educational reform in Ukraine. It is also necessary to determine the strategy for the development of education in the country, and for this you need to thoroughly analyze, summarize and creatively use all the accumulated historical experience.

The object of the study was the Ukrainian society in its ethnic composition in most cases, including Kyiv, Podillya, Volyn, Poltava, Chernihiv, Kharkiv provinces of the Russian Empire in the first half of the XIX century.

The purpose of our study is to study the features of public education in the Ukrainian lands. The educational policy of the autocracy on certain

classes, social and ethnic groups of the population is analyzed, the process of founding and development of Kharkiv and Kyiv universities – centers of elite national self-consciousness is revealed, normative documents (statutes) of educational institutions of different levels and forms of organization the middle of the XIX century.

General scientific and special historical methods were used during the writing of the monograph. In particular, the systematic approach, which is based on the principles of multifactorial conditionality, allowed to take into account the influence of political, social, cultural and economic factors on the development of education in the lands of forest-steppe Ukraine. Emphasis was placed on identifying the nature and diversity of the relationship between tsarist policy in education and other components of social life in accordance with the principles of objectivity and comprehensiveness. Synchronous, historical-genetic, historical-systemic method allowed to study the phenomenon in development.

The structure of the work is determined by the purpose and objectives of the study. The historiography and source base of the research were analyzed, the range of tasks that were not solved by previous researchers was outlined. The next section focuses on the peculiarities of the educational policy of the autocracy in the Ukrainian lands. The ideology and practice of autocracy in the field of public education in Ukraine are considered. Particular attention was paid to the formation of university education and its impact on the emergence of the Ukrainian national educational movement.

2. Analysis of recent research and publications

The study of the history of the formation of the system of public education in the forest-steppe Ukraine in the first half of the XIX century is based on documents and materials of different origins. The study of the history of the establishment of a system of public education in the Ukrainian forest-steppe provinces in the first half of the XIX century is based on documents and materials of different origins. As the information base of the offered section were used statistics on the state of education of the population in the provinces of the Forest-Steppe Ukraine, published in 10 and 12 volumes of the “Military Statistical Review of the Russian Empire” [1; 2; 3; 4; 5; 6]. Almost simultaneously with this publication, the Statistical Committee was established under the Ministry of the Interior on the basis of the Statistical Office and the

Lustration Committee for the Western Provinces in 1852. Since 1855, the provinces have received updated rules for the collection and processing of statistical information, which generally replicate and detail the approaches taken by officers of the General Staff. As a result, statistical reviews of the Russian Empire became more analytical and informative [7; 8; 9].

An important source of statistical data on the socio-economic development of the provinces of the forest-steppe Ukraine of the second half of the 50's – early 60's of the XIX century are “Commemorative Books” prepared by the provincial statistical committees on the basis of information collected for the government's Statistical Committee and published for the general public in local printing houses. In order to gain popularity among local readers, the texts acquired a journalistic and descriptive character, and a number of statistical data related to the activities of the Ministry of the Internal remained unpublished for censorship reasons [10; 11].

It is known that in pre-revolutionary Russia there was no single piece of legislation that would cover the entire field of education. Laws regulated the activities of certain types and levels: the provisions of the primary public school, the statutes of gymnasiums and schools, university statutes, and etc. To better understand the problem, we analyzed such types of legal sources as legislative acts of a general imperial nature, which covered the central links of the Russian education system [12].

An in-depth study of the process of creation and activity of Kharkiv and Kyiv universities would be impossible without the scientific achievements of their first researchers. Meticulous analysis of the prehistory of educational institutions, characteristics of the first teachers and rectors, the dynamics of changes in the social composition of students under the influence of educational policy of the autocracy – all this allows us to use their work not only for historiographical analysis but also as sources of information about the educational environment [13; 14].

Modern analysis of the development of the public education system in the northeast of Ukraine in the period XVIII – first half of the XIX century allowed to identify key regional features of its development. We must agree with the authors' conclusion on the strengthening the state regulation of educational institutions in the first half of the nineteenth century [15].

The history of the formation and functioning of military education in the Ukrainian lands, in particular, cadet corps, was studied by A. Makhinko

[16]. The scientist focused on the fact that from the 30s to the 60s-70s of the XIX century. Cadet corps were the only type of institution that supplemented the officer corps with military specialists.

The study of the history of gymnasium education, primarily as a type of urban educational institutions for full secondary education and preparation to university, became the subject of scientific research V. Milko [17]. The author meticulously, using a significant number of sources and literature analyzed the legal framework for regulating the process of creation and development of gymnasiums in the Russian Empire in the XIX century. The main attention is paid to the system of management of secondary educational institutions operating in Ukrainian cities.

Features of the policy of the Russian Empire on schooling of national minorities of the Right Bank of Ukraine during the XIX century revealed in the monograph by Y. Polishchuk. The researcher noted the Polish education abolition as autocracy revenge for the active participation of the Polish right-wing nobility in the uprising of 1830–1831 and studied the process of state control and unification of the educational process in Jewish, German and Czech schools [18].

O. Kryzhanovska emphasized the importance of the primary parish school for the peasants education [19]. However, we do not agree with her conclusion about a fairly high level of public education in the Ukrainian lands in the first half of the nineteenth century. The sources involved in our work convincingly show that the Ukrainian provinces lagged behind not only the Baltic provinces but also most of the central provinces of European Russia.

Analysis of the historiography of the problem shows that the attention of researchers is focused on the study of certain elements of public education, the level of education of social classes or national minorities. The study of general features of the state's educational policy in the forest-steppe provinces and its influence on the formation of the foundations of the national self-consciousness of the Ukrainian people, the public struggle for equal and fair general character of all levels of education remains beyond scientific research.

3. Educational policy of the autocracy in the provinces of Forest-Steppe Ukraine (first half of the XIX century)

At the beginning of the XIX century, the Ministry of Public Education was established in the Russian Empire under the influence of liberal and enlightenment ideas that were spreading in Europe. In January 1803, Emperor

Alexander I approved the “Preliminary Rules of Public Education”, which were based on the idea of a secondary school necessary for the education of the population. The education system, which was subject to the ministry, consisted of parish schools, county schools, gymnasiums, and universities. Curricula in educational institutions were designed in such a way that each lower level of education was a step towards the next, including the university.

The main task of the ministry was to registration of the system of educational districts, opening of new universities and their transformation into regional centers of education system management, development and approval of the statutes of educational institutions on the principles of autonomy in matters of internal governance and court. On November 5, 1804, the “Charter of educational institutions under the jurisdiction of universities” was approved, according to which a network of educational institutions was created, which was formally of a general nature [12, p. 94]. However, access to education was restricted to women and children of serfs. At the same time, the formation of a number of privileged educational institutions – lyceums for the education of the elite.

With the beginning of the reign of Emperor Nicholas I (1825), education ceased to be seen as a means of educating the population and became a leader of autocratic ideas in the youth environment. The main task of institutions of all educational levels was to educate the emperor loyal subjects, obedient sons of the state and the church. Another direction of educational evolution in those days was the attempt to differentiate the provision of education in accordance with the social status of students. Another component of the transformation in the organization of the educational environment of the Russian Empire in the late 20s of the XIX century was the total unification of educational institutions, the introduction of strict discipline and uniform and unchanging requirements for teaching and education. All this was reflected in the Charter of Gymnasiums and Schools of December 8, 1828.

By the early 60’s of the XIX century. the development of education in the Russian Empire depended solely on the will of the autocrat, implemented through his government. However, the socio-political movement caused by and supported by bourgeois reforms (peasant, judicial, zemstvo, military) directed efforts to solve urgent social problems – education of the people, democratization of the educational system, the formation of primary

national, women's and vocational education, taking into account the needs of socio-economic development of the country.

Real actions were taken to develop primary public education, which led to the development of a mass national school, created the conditions for public initiative in the organization of public education. Significant changes have also taken place in the field of secondary school, which has been proclaimed to be universal, accessible and open to all classes. However, tuition fees closed access to secondary education for children from low-income families. The autocracy abandoning the feudal-caste principle of the organization of education and introduced a class bourgeois school through property qualifications.

According to the Statute of 1804, universities were given autonomy, a collegial form of government and freedom of teaching. The rector of the university was elected by the professors at the general meeting and was subordinate to the trustee. The rector not only headed the university, but also managed the educational institutions of his district. Directors of provincial gymnasiums not only direct management, but also supervised all schools in the province. Caretakers of county schools were subordinate to them. They, in turn, took care of the parish schools of the respective administrative district. Thus, the administration of educators was formed from specialists who were well versed in their field.

By tsarist decree, the Russian Empire was divided into 6 educational districts, each headed by a university in 1803. The right-bank Ukrainian provinces (Kyiv, Podillya, Volyn) first became part of the Vilnius educational district. They were guided by trustees (curators) of educational districts. The curator was responsible for administrative oversight and liaison between the ministry and the university. In the middle of the 19th century, Kyiv and Kharkiv educational districts operated on the territory of Ukraine, which is the subject of our research.

Lyceums occupied an intermediate place between gymnasiums and universities – Kremenets in Volyn (1819), founded on the basis of the gymnasium, after the Polish uprising of 1830–1831 closed, and then transferred to Kiev and reorganized into the University and Nizhyn, which in 1832 was established on the basis of the Gymnasium of Higher Sciences, founded in 1820 at the expense of the Bezborodko brothers.

Gymnasiums (seven years of study since 1828) – provided a complete secondary education and prepared for university entrance. The content of

education was encyclopedic: Latin and foreign languages, mathematics, geography, general history, philosophy, political economy, technology and commerce were studied. Boarding schools were opened at the gymnasiums, their pupils were additionally taught French, dance, music, fencing and horseback riding. Starting from the fourth year of study, gymnasiums were divided into classical and real. Classics prepared for admission to universities and other educational institutions. The main focus was on the study of ancient languages, Russian literature, foreign languages and history. The real ones were aimed at preparing for military service and polytechnic education, and instead of ancient languages, they taught practical mathematics and jurisprudence.

The development of gymnasium education in the Right Bank of Ukraine had a number of features that can be demonstrated by the example of the Podillya province. The Vilnius educational district included Vinnytsia, Bar, Kremenets and Nemyriv schools in 1803, which at that time were equated with gymnasium education. Teaching was conducted in Polish, and Russian was studied on a par with Latin or German. However, after the defeat of the First Polish Uprising of 1830–1831, the existing gymnasiums were disbanded, and on their basis, educational institutions of national standard were created.

Institutes of Noble women provided opportunities for young people to receive secondary education, aesthetic and ethical education and, upon graduation, the right to become governors of children of nobles and clergy. Admitted to the institute representatives of mostly the nobility, daughters of the clergy and merchants of the first two guilds. The term of study varied from six (Kharkiv Institute) to seven years (Poltava). In the late 50's of the XIX century, began to establish women's schools in provincial cities, which in honor of the Empress were named Mariinsky. According to the statute, girls of all classes had the right to study without distinction of religion or nationality. Eventually, these schools will be transformed into women's gymnasiums.

County schools (three years of study) prepared students for further education in high schools and for practical activities. There were many more subjects in the curricula than in the parish schools – church history, God's law, Russian language, arithmetic, geometry, geography, history, drawing, sketching. Teachers were required to use only textbooks recommended by the Ministry. Representatives of the taxable classes studied in schools – the

children of merchants, burghers, artisans. In addition, at the county schools, additional courses could be opened to teach commercial sciences and accounting, to study the basics of mechanics and technology, agriculture and horticulture with the permission of the Ministry of Education [12, p. 253].

Among the schools, purely aristocratic ones were singled out, where children were prepared for further study in the gymnasium and science was taught in the same manner and according to the same textbooks as in the first three grades of the gymnasium.

The programs of church-parish (parish) schools were designed for one year of study. They were intended for people of the “lowest classes” [12, p. 247]. Schools could open in provincial, county towns and cities, as well as in large towns. Their goal was to provide children with general knowledge (boys and girls could study here, but in separate classes) and to prepare those wishing to study in county schools. The main subjects were the Law of God, reading and spelling, elementary arithmetic. Parish schools for serfs were maintained at the expense of peasants and landowners, so they developed slowly. Schools for children of state peasants operated under the auspices of the Department of State Property.

Without state support, at the expense of parents, public schools appeared at churches. The deacons taught the children to read primers, chasos and psalters, as well as church songs, mostly in Ukrainian. They did not provide opportunities for further education. Without government support, at the expense of parents, public schools appeared at churches.

In addition to the state, theological schools continued to operate in Ukraine, including the Kyiv Theological Academy, founded in 1632 by Metropolitan Peter Mohyla and long known as the Kyiv-Mohyla Collegium. In the mid-40s of the XIX century. 120 students studied at the expense of the state. The training lasted four years, and most of the graduates held senior administrative positions in the structure of the Russian Orthodox Church. There was also a Roman Catholic seminary and Catholic parish schools at the churches, single Lutheran schools for the children of German colonists.

The Ministry of Education paid considerable attention to the control of Jewish education, especially in the provinces of the Right Bank of Ukraine.

In the structure of military education of the Russian Empire, the leading place belonged to the cadet corps, which were special educational institutions for the training of future officers. They operated in Poltava and

Kyiv during the research period. In addition, there were specialized military schools (cantonal squadrons, paramedic and surveying schools, etc.) within military settlements and troop locations.

From the second half of the 50s of the XIX century, the development of a primary public school began at the initiative of the progressive community in the Russian Empire. In October 1859, with the support of the trustee of the Kyiv educational district M. Pirogov, Sunday schools began to open. "Sunday schools are important not so much in our country, because they spread literacy in the most reliable way, namely through private initiative and charity, but because they encourage artisan and working people to study» – wrote a prominent surgeon and humanist [20, p. 305].

The Russian Orthodox Church believed that the right to run a public school should belong to it, not to the Ministry of Education, and even more so to the public, because the clergy are the first and most reliable educator and guardian of public morality. Alexander II allowed the popular schools founded by the clergy to remain under the control and maintenance of the Church for the reconciliation of the parties.

In 1864, the Regulations on Primary Public Schools were approved. According to him, all types of public schools were united under one name. Their term of study was one year, and the curriculum corresponded to the old parish schools. The schools were general and were maintained mainly by public and private donations, as well as funds from the agencies to which they belonged. Training was conducted exclusively in Russian. By refusing to finance public education, the tsarist government placed this responsibility on the zemstvos. A significant share of zemstvo expenditures on primary school was peasant funds. Thus, in the Kharkiv provincial zemstvo peasant contributions for educational needs accounted for more than half of all its revenues [12, p. 578].

Liberal reforms initiated by Emperor Alexander II stimulated public awareness of public education. Since the late 50's of the XIX century, statistical information has become more detailed, including data on the number of parish schools established in churches, monasteries, and under the auspices of the State Property Office.

Note that the statistical material on this subject, collected and processed by us, was analyzed using chronological, statistical and comparative-historical methods. Further generalization of these data is complicated by the lack of a single form of statistical reporting.

Educational indicators of the Russian Empire were a kind of indicator of the total lag behind European countries not only in terms of socio-economic development but also in terms of human capital. At the beginning of the second half of the XIX century in 49 European provinces of the Russian Empire, one student per 133 inhabitants. For comparison, in Austria the proportion was 1 student per 15 people, in France and Great Britain – 1 per 11, in Prussia – 1 per 6, and in the North American United States – 1 student per 5 inhabitants [8, p. 273].

Kharkiv and Kyiv provinces were among the most economically and culturally developed territories of the Ukrainian Forest-Steppe. Thanks to the universities, Kharkiv and Kyiv quickly became regional educational centers.

In addition to the classical university in the Kharkiv province, there were specialized vocational schools: paramedic and agricultural schools, where representatives of the taxable state had the opportunity to study. The government, paying some attention to improving the culture of agriculture, promoted public lectures on agronomy, chemistry and applied mechanics.

Noble education depended on the wealth of the family. “For a long time, the rich people of Little Russia prescribed governors from Switzerland and France to raise their children”, said a contemporary [5, p. 180]. Long since rich people from Little Russia discharged governors from Switzerland and France to raise their children. Simultaneously with the development of the network of higher classes of educational institutions (universities, gymnasiums, institutes of noble girls, private boarding houses), representatives of higher classes sent their children to study in the capital and provincial cities. This led to the fact that the cost of educational services increased and became an obstacle to the education of children of nobles with average wealth. Thus, in Kharkov, a year of study and living at the Institute of Noble Girls or in a private boarding house cost from 1,500 rubles in money orders. A landowner or clerk who had several daughters had to allocate several thousand rubles a year for their education. At the same time, studying at the gymnasium for young people also required significant costs. During the 1840s, among the privileged classes of the population, the nobility and the officers’ children, the ratio between students and others ranged from 1 to 15, although in Europe at the time the generally accepted proportion of all children enrolled in education was make 1 to 3 – 1 to 6. Most girls from higher classes and a significant number of boys received home schooling due to lack of funds in the family.

The upbringing of merchant youth, who were also considered to be privileged, depended significantly on the financial capabilities of their parents. Merchants of the I and II guilds tried to give better education and upbringing to their daughters in private boarding houses, for their possible marriage to the nobility, while the sons usually learned from their parents the intricacies of trade. The proportion of merchant children who studied in the relevant institutions to the total number of merchants was 1 to 20 [5, p. 180].

During this period, the education of one of the highest classes of the Russian Empire (clergy) improved. The vast majority of sons inherited the privileges of their parents only if they studied in seminaries and seminaries. At the same time, most of the clergy did not have the necessary funds to provide their daughters with appropriate upbringing and education in boarding schools, so the overall ratio of those covered by education for their social execution was 1 to 33.

Lower (taxable) states had even more limited opportunities to educate their children. Thus, despite the rapid increase in the number of burghers, only one in 90 of them studied in the institutions of the Kharkiv province. For artisans (“guilds”), the proportion was 1 to 260. Dissenters contributed much better to the education of their children, as indicated by the ratio of students to the whole group, as 1 to 21.

Rural parish schools under the Department of State Property have been operating since 1843 in the Ukrainian provinces. Children of state peasants could study in them, as well as in parish schools. Their proportion to the group in 1847 was 1 to 260. This does not take into account the children of Ukrainian military settlers who could learn to read, write and count at best from clerks and retired lower ranks who knew literacy. The education of landlord peasants was a manifestation of the good will of the landlords. “Nothing can be said about the education of landlord peasants, because except for a few yard boys, none of the peasants studied literacy, and landowners do not educate them at all because they do not benefit from it, and therefore do not want to spend their money on it”, – the witness points out [5, p. 182–183].

Turning to the analysis of the state of education in the Kiev province in the mid-nineteenth century note that here we have more sources and they are better classified.

Kyiv played the role of an Orthodox spiritual center due to its ancient history and religious buildings. Pilgrimage to holy places (Kyiv-Pechersk

Lavra), the presence of a higher Orthodox educational institution – Kyiv Theological Academy, created the conditions for the development of spiritual education, which also included a seminary, county and parish theological schools. Another feature of the Kyiv province was the large number of Jews who had their own traditions of schooling, providing Jewish children with knowledge of Jewish liturgical books and the basics of basic literacy. In the mid-1840's, the proportion of those who studied in relation to the total population of the Kiev province was 1 to 288 [1, p. 140].

In the next 10 years, significant quantitative and qualitative changes took place in the education of the Kiev province.

First, powerful military schools were established that competed with the university. The cadet corps (military gymnasium) combined general and military-special courses in the curriculum. Only representatives of the nobility could study there. Two-year special courses were opened at all cadet corps in 1857. Nobles with secondary and higher education, not nobles with higher education could enter externally in special classes of cadet corps. The military (cadet) school trained junior officers. The opportunity to study there was open to all classes, except Jews and serfs.

Secondly, the number of children of the clergy, dissidents, burghers and peasants increased at the university (25% of the total number of students) and in gymnasiums. The opportunity to obtain a higher social status and the corresponding privileges was directly related to the level and quality of education.

Third, the regulation of Jewish education took place. Jewish schools, as well as evangelical Lutheran schools, provided primary education to members of certain religious and ethnic minorities in the Russian Empire. As a rule, the school had one teacher, who also performed supervisory functions.

Fourth, in the statistics, the category of schools at churches, estates and under the auspices of the State Property Office, created for the education of peasant children, appeared for the first time. Accordingly, the number of parish rural schools decreased. Thanks to these measures, the number of people who studied in 10 years has doubled.

Fifth, status and confessional-national inequality were complemented by gender. The principle of gender equality was observed only in educational institutions established by people from Protestant countries [7].

Quantitative and qualitative indicators of public education in other Right-Bank provinces (Podillya, Volyn) differed significantly against the background of an underdeveloped educational system in the mid-nineteenth century. A number of factors contributed to this. Polish by descent right-bank gentry, during the first third of the nineteenth century, actively developed the Polish, aristocratic education, cherishing the hope of maintaining its position as the ruling class in the Right Bank of the Forest-Steppe Ukraine under the conditions of the Russian Empire. The peasantry, the vast majority dependent, did not have the opportunity to join education. Therefore, the number of county schools at the Department of State Property was extremely small.

The nobility and officials of Podillya could teach their children in gymnasiums and parish schools, while the clergy filled their estates in educational institutions. The vast majority of young people covered by at least some education were representatives of the Jewish community, who, occupying only 11% in the demographic structure of the Podillya region (168,189 people) had 1 student for 15 adults [3, p. 137].

In an attempt to somehow improve the statistics of public education in the Volyn province, 1,064 parish schools opened in 1837 were taken into account [4].

4. Features of the formation and development of university education in the forest-steppe Ukraine of the first half of the XIX century

The first university in Ukraine was opened in the early nineteenth century, in the city of Kharkiv, which as a small provincial city managed to build a higher education institution not only faster than Kyiv, but also earlier than the capital of the empire. Researchers, in search of an explanation for this phenomenon, drew attention to economic factors that gradually turned Kharkiv into a center of transit trade between Central Russia, the Don, Crimea, the Right Bank and Western Europe, which contributed to capital accumulation and the exchange of progressive ideas.

Historical and cultural factor was no less important. Immigrants from Bratslav and Kyiv regions inhabited large areas of Slobidska Ukraine in the second half of the XVII century. Brotherhoods, hospitals, and schools were brought to Kharkiv. Public schools have undergone special development, created by the churches. In the first half of the XVIII century a secondary

school was established in Kharkiv, the Kharkiv Collegium, which educated not only the children of the clergy, but also of Cossack officers, Cossacks, and burghers. Among his teachers was a prominent Ukrainian philosopher and educator Hryhoriy Skovoroda. His popularity and authority among all classes of society was undeniable. The founder of the university V. Karazin noted the Ukrainian wandering philosopher: “We had our Pythagoras, Origen, Leibniz under the forehead and in the Ukrainian scroll” [14, p. 3].

In the history of Kharkiv University there was a feature that it arose due to the educational and organizational activities of one person – Vasyl Karazin. During the meeting of the Kharkiv nobility in August 1802, V. Karazin proposed to create in Kharkov not just a classical university on the German model, but a general higher education institution, which was to consist not of faculties but of a number of departments: general knowledge, medical knowledge, theologians, military knowledge, civil arts, etc. In addition, the structure of the educational school of agriculture and craft school were to be included in the rights of separate units. According to V. Karazin, the university should have become a public institution in the full sense of the word: maintained at public expense, guided by a board of professors and representatives of the nobility, who made donations for its creation and development. Thus, the Kharkiv nobility donated 400 thousand rubles, Ekaterinoslav – 80 thousand, Kherson – 30 thousand, merchants and cities – about 50 thousand rubles. Kharkiv military residents, descendants of former Sloboda Cossacks, communities of Zakharkivska, Zalopanska and Ivanovo settlements gave up 125 tenths of suburban lands in favor of the university. The plans were to establish a campus, which also required significant investment [14, p. 6–7].

Having received donations that gave Kharkiv the moral right to establish a university, V. Karazin intensified his ties in St. Petersburg. Emperor Alexander I allowed the establishment of a university in Kharkov and the opening of the Kharkiv educational district in January 1803. Kharkiv University was inaugurated on January 17, 1805, which began its work on the basis of a fairly liberal statute.

In 1835, the new General Statute of Russian universities came into force, which reflected the reactionary-conservative tendencies of the reign of Nicholas I. S. Uvarov, Minister of Education, became the author of the Russian great-power doctrine, which was later called the “Theory of

Official Nationality”. The formula “Orthodoxy-autocracy-nation”, which was popular later, reflected the conservative-conservative ideology directed against the revolutionary-liberal ideas. There was a strengthening of the trustee’s power and restrictions on university autonomy. The trustee was obliged to control the finances of the university, use all means for the development of the educational institution, supervise the strict performance of all officials, pay attention to the abilities, diligence and reliability of professors, associate professors and other university staff. Thus, the trustee became the appointed head of the university. At the same time, the rector’s power was strengthened, which gradually began to acquire a well-known and traditional character for higher education. The rector was elected by the university council for 4 years and was to ensure the development and improvement of the educational institution. If before the board of the university had the right to sue the rector, the rector received the right to announce reprimands and remarks to professors and received an assistant – vice-rector. [12, p. 366–367].

At the same time, the number of disciplines taught at the university was increased, the position of associate professor and teacher training at the University of Dorpat and abroad were introduced. However, the revolutionary events of 1848 in Europe led to an even greater strengthening of conservative tendencies in the university environment. Strict observance of discipline and law and order was declared, the number of students who could study at their own expense was limited. “To clean up universities” from unreliable ones, the complexity of exams was increased trips to study abroad were prohibited [14, p. 6–7]. The liberal reforms of Alexander II intensified university life in the late 50’s – early 60’s of the XIX century. In the middle of the XIX century the most popular among students of Kharkiv University were legal sciences, then – philosophical and mathematical, medicine and natural sciences [5, p. 184].

The first attempt to establish a university in Kiev on the initiative of the Minister of Education of the Russian Empire P. Zavadovsky took place in 1805. The need to organize a new educational district with its center in Kyiv in the newly created provinces of the Right Bank of Ukraine was determined by two reasons. First, the Vilnius educational district was too large for effective public administration. Secondly, the establishment of Kharkiv University became possible with the active participation of local

nobility, merchants and townspeople. Therefore, the Minister tried to gain the necessary support of the local nobility, merchants and burghers, after a visit to Kiev. However, the curator of the Vilnius educational district was appointed Polish magnate Prince A. Czartoryski, who combined this position with the position of Comrade Minister, and later Minister of Foreign Affairs of the Russian Empire and was a personal friend of Emperor Alexander I. No less energetic Polish aristocrat T. Chatsky was appointed a visitor (a person who was responsible for visiting certain facilities to confirm their improvement) to the schools of the school district, which included all the provinces of the Right Bank of Ukraine. Representatives of the former Polish nobility incorporated into the Russian nobility used the support of Russian high-ranking officials and undertook to further develop not national but Polish education. Their goal was to preserve the dominant position of the Polish aristocratic class on the territory of Right-Bank Ukraine. For this A. Czartoryski contributed to the preservation of teaching in Polish in educational institutions of the district. Also, Rector of Vilnius University I. Stroinovskiy gave full support to the Polonization of education.

T. Chatsky's arguments against the establishment of the University of Kyiv were as follows: it is inappropriate to open a university in Kyiv, as a university in Kharkiv has already been opened near Kyiv. Secondly, Kyiv is located away from the north-western edge, and is at a disadvantage for such an institution. Third, the desire of citizens who are willing to make charitable contributions to the development of education is to study in Polish, which cannot be achieved in Kyiv, where civil law will be taught on the basis of Russian rather than local (Polish) and ecclesiastical law on the basis of law Eastern (Orthodox). In addition, the Orthodox clergy do not have the necessary level of education [13, p. 35].

We must agree with the statement of researcher A. Bondar that the trustee of the Vilnius educational district A. Czartoryski and the visitor of education T. Chatsky primarily defended the interests of education of Poles and Catholics [21], including almost all landowners, many burghers, citizens, courtiers and there were no serfs. P. Zawadowski favored the arguments on maintaining Polish control over educational processes on the Right Bank, not least because the reform of education in the Russian Empire was influenced by the Polish educational reform of the 70s of the 18 century. Thus, the first trustee of Kharkiv University was a Polish magnate by birth

S. Potocki. In addition, the Polish aristocracy when entering the ruling state of the Russian Empire after the partition of Poland, their rights and privileges were preserved.

In 1805, the gymnasium in the town of Kremenets in Volhynia was founded by the efforts of T. Chatsky and with the support of the Polish nobility, which became an important Polish cultural center. Since its founding, the gymnasium has actually been a university in miniature. Training was divided into 2 levels. The first, which lasted four years, taught the languages and beginnings of arithmetic, geography, ethics, etc., the second, which lasted six years, taught geometry, algebra, logic, history, physics, chemistry, higher mathematics, law. According to the charter of the gymnasium, students had the opportunity to listen to courses in anatomy, physiology, surgery, agriculture, horticulture, architecture, practical mechanics. In 1819, the Kremenets Gymnasium was renamed the Lyceum, but there were no changes in the internal organization of the institution and the expansion of its rights. Out of more than 600 lyceum students, only 34 belonged to the Orthodox faith [13, p. 54].

The Polish uprising of 1830–1831 led to a major turn in the educational policy of the Russian Empire. It is known that many students and teachers of Vilnius University were involved in the riots. A significant number of lyceum students also supported the insurgents. Therefore, Kremenets Lyceum was closed on August 21, 1831. His fate was divided by the University of Vilnius in May 1832, and at the same time the Vilnius Educational District was disbanded. All gymnasiums and county schools of the Right Bank of Ukraine (except those located in Kyiv) were closed, which were under the influence of the Polish aristocratic class and the Roman Catholic clergy and served as leaders of the Polish state tradition. Minister of Education S. Uvarov informed the tsar of the need to “to close these schools and in their place in the Volyn and Podolsk provinces to introduce in time the teaching of Russian literacy, Russian Catechism and arithmetic in the churches of the Greek-Russian confession, leaving them under the supervision of parish priests: because only then with the movement of the clergy of the Western Church” [13, p. 59].

Thus, no less severe Russification and unification of the educational process on the scale of the empire was an alternative to the Polonization of the Ukrainian population, which unfolded in the early 30s of the XIX century after the final suppression of the Polish uprising.

The Minister proposed to open a new educational district in Kyiv. At the same time, the Chernihiv and later Poltava provinces were annexed to the right-bank provinces that were part of the district. The decree on the establishment of the University of Kyiv was issued on November 8, 1833. It mentioned the transfer of the Volyn Lyceum from Kremenets to Kyiv. The decree of December 25, 1833 clearly stated the purpose of his educational mission – to be the leader of all-Russian education [13, p. 66]. The Charter of the new university, which was in force until 1842, was also approved, despite the introduction of the general charter of Russian universities in 1835.

The grand opening of the University of Kiev took place on July 15, 1834 – on the day of St. Vladimir, whose name was given to the newly established educational institution. The first rector of the university was a native of Poltava M. Maksymovych, the second rector – V. Tsykh from Kharkiv region, the third O. Novitsky from Volyn. If at the beginning only the Faculty of Philosophy worked at the university with two departments: historical-philosophical and physical-mathematical, then during 1835-1836 the Faculty of Law was formed.

The study at the university lasted four years. A feature of the first years of operation of the University of St. Vladimir was the rule enshrined in its charter, to conduct an entrance exam for applicants. At the same time, the right of admission was granted to all comers, not just high school graduates. Although it is clear that the level of preparation of entrants after high school and county or monastery schools differed significantly. The empire accepted other universities solely on the basis of high school results. Therefore, out of 75 entrants who applied to the university, only 59 passed the exams, and three more were enrolled without exams. Thus, the first year in 1834 enrolled 62 students, of whom 30 were Catholics and 28 Orthodox.

The number of students has quadrupled in the first four years, in line with the gradual opening of new courses. Therefore, the total number of students in the first years of the university was about 250, which in turn was about 80 per faculty, or 20 per course. The initial quantitative parity between Orthodox and Catholics in the following years was changed in favor of Catholics. The reason was the predominance of the Polish nobility on the Right Bank, and also depended on the class of students at the university. In the Podillya, Volyn and Kyiv provinces in the late 30s of the XIX century the denominational majority were Orthodox and Greek Catholics, but this

majority was made up of clergy, peasants, and some burghers. The children of the Uniate clergy were to be expected at the university, but according to the instructions of the imperial authorities it was necessary to obstruct their children when entering secular educational institutions. Uniatism within the empire was abolished in 1839. The Orthodox clergy, for the most part, remained rather poor, and believed that studying in Orthodox theological institutions would provide employment as a parish priest and at least some wealth. In addition, it was necessary to get out of the spiritual state to study at the university, which led to the loss of hereditary privileges.

The peasantry, the bulk of which, at least on the Right Bank, remained in serfdom, the vast majority were outside the educational process, having neither the rights nor the necessary funds. It should be noted that the university owned not only lands and estates, which he inherited mainly from the Kremenets Lyceum, but also peasants¹, and as a result had some income.

Nobles and children of officials remained the main contingent of university students. Catholic students preferred the 2nd branch of the Faculty of Philosophy, where the natural sciences predominated, while the Orthodox mostly sought to enter the Faculty of Law, the successful completion of which contributed to the further career of the official. During 1837–1838, the number of law students was the majority. The 2nd department received well-off people, descendants of rich landowners, while the 1st department of the Faculty of Philosophy, which was dominated by the study of philology and history – poor, mostly dissidents by origin, who could only dream of a career as a teacher [13, p.150].

Kyiv University is becoming the cradle of the Ukrainian national movement, despite strict measures to monitor the reliability of students and the persecution of any manifestations of free thought – since the mid-40s of the 19th century. Students, teachers and graduates of the University of Kiev were the main participants in the secret Ukrainian political organization, which was named the Cyril and Methodius Society (1845–1847).

It is unknown exactly who was the organizer of the society. Usually, the surnames M. Kostomarov, M. Gulak and V. Bilozersky are mentioned. The members of the society were P. Kulish, T. Shevchenko, O. Navrotsky, G. Andruzky, I. Posyada, M. Savych, O. Markovych, D. Pilchikov.

¹ During the people's audit of 1851, the Volyn State Chamber announced that it had accepted 1,265 peasants from the University of Kyiv on the state balance.

The main program provisions of the society were set out in the Book of the Existence of the Ukrainian People, which should not be considered a political program of the conspirators, but rather a romantic dream of the ideal structure of the future Pan-Slavic Brotherhood. In particular, it was proposed to create a federation of Christian Slavic republics in which serfdom was abolished, privileges were established and social democratic ideals were established; equality in the rights to the development of the national language, culture and access to education for all Slavic peoples was introduced. This work combines the ideas of early Christianity, social justice, historical romanticism with the desire of young members of the Ukrainian intelligentsia to protect the Ukrainian people from the tsarist attack on their rights.

In March 1847 the society was defeated after the denunciation of the student O. Petrov. All members of the organization were exiled, with the exception of Taras Shevchenko, who was drafted into the army for his anti-monarchical, pro-Ukrainian orientation.

The main practical goal of the society was to be educational activities among Ukrainians. Panteleimon Kulish said during the interrogation of the gendarmes of the 3rd Department that he considers the best distribution of schools for Ukrainians and the spread of general literacy to be the best circumstances. This intention was realized only with the beginning of the liberal reforms of Alexander II and the possibility of establishing Sunday public schools outside of state influence in the late 1850s – early 1860s. Panteleimon Kulish wrote and published a textbook for beginners “Grammar” and M. Kostomarov founded a fund for the publication of Ukrainian textbooks.

5. Conclusions

Thus, the formation of a system of educational institutions and the organization of management of this system in the first half of the nineteenth century in the Russian Empire testified to the complete dependence of the educational policy of the autocracy on the will of the autocrat. In the 1930s, the influence of the Polish aristocracy on educational processes in the provinces of Right-Bank Ukraine was overcome and Russificationist policy was strengthened under reactionary-conservative slogans using harsh administrative and repressive measures of tsarism. Education becomes an

instrument of the policy of the autocracy, aimed at protecting the existing feudal system.

The opportunity to receive an education directly depended on the social status and place of the person in the hierarchy. The vast majority of Ukrainian serfs did not have the opportunity to teach their children at all, as their education depended on the good will of the landlords and was not regulated by the state.

In these circumstances, the Ukrainian intelligentsia affected the interests of the oppressed people, who, despite autocratic barriers, focused their energy on studying the history, culture, language and customs of the people, which in turn led to the politicization of protest and the emergence of Ukrainian national education movement.

References:

1. Departament General'nogo Shtaba Rossiyskoy Imperii (1848). *Voennostatisticheskoe obozrenie Rossiyskoy Imperii, izdavaemoe po Vysochayshemu poveleniyu pri 1-m otdelenii Departamenta General'nogo Shtaba. Kievskaya guberniya po rekognostsirovkam i materialam, sobrannym na meste, sostavlyal Gen. shtaba kap. Men'kov* [Military Statistical Review of the Russian Empire, published by the Highest Command at the 1st Branch of the Department of the General Staff. The Kiev province, according to reconnaissance and materials collected on the spot, was Gen. headquarters cap. Menkov] Saint Petersburg: Typography of the General Staff, vol. 10, part 1. (in Russian)

2. Departament General'nogo Shtaba Rossiyskoy Imperii (1848). *Voennostatisticheskoe obozrenie Rossiyskoy Imperii, izdavaemoe po Vysochayshemu poveleniyu pri 1-m otdelenii Departamenta General'nogo Shtaba. Poltavskaya guberniya po rekognostsirovkam i materialam, sobrannym na meste, sostavlyal Gen. shtaba podpolk. Obleukhov* [Military Statistical Review of the Russian Empire, published by the Highest Command at the 1st Branch of the Department of the General Staff. The Poltava province, according to reconnaissance and materials collected on the spot, was Gen. headquarters of the lieutenant colonel Obleukhov]. Saint Petersburg: Typography of the General Staff, vol. 12, part 3. (in Russian)

3. Departament General'nogo Shtaba Rossiyskoy Imperii (1849). *Voennostatisticheskoe obozrenie Rossiyskoy Imperii, izdavaemoe po Vysochayshemu poveleniyu pri 1-m otdelenii Departamenta General'nogo Shtaba. Podol'skaya guberniya po rekognostsirovkam i materialam, sobrannym na meste, sostavlyal Gen. shtaba kap. Tveritinov* [Military Statistical Review of the Russian Empire, published by the Highest Command at the 1st Branch of the Department of the General Staff. Podolsk province, according to reconnaissance and materials collected on the spot, was Gen. headquarters cap. Tveritinov]. Saint Petersburg: Typography of the General Staff, vol. 10, part 2. (in Russian)

4. Departament General'nogo Shtaba Rossiyskoy Imperii (1850). *Voennostatisticheskoe obozrenie Rossiyskoy Imperii, izdavaemoe po Vysochayshemu poveleniyu pri 1-m otdelenii Departamenta General'nogo Shtaba. Volynskaya guberniya po rekognostsirovkam i materialam, sobrannym na meste, sostavlyal Gen. shtaba kap. Friche* [Military Statistical Review of the Russian Empire, published by the Highest Command at the 1st Branch of the Department of the General Staff. Volyn province, according to reconnaissance and materials collected on the spot, was Gen. headquarters cap. Fritsche]. Saint Petersburg: Typography of the General Staff, vol. 10, part 3. (in Russian)

5. Departament General'nogo Shtaba Rossiyskoy Imperii (1850). *Voennostatisticheskoe obozrenie Rossiyskoy Imperii, izdavaemoe po Vysochayshemu poveleniyu pri 1-m otdelenii Departamenta General'nogo Shtaba. Khar'kovskaya guberniya po rekognostsirovkam i materialam, sobrannym na meste, sostavlyal Gen. shtaba kap. Mochul'skiy* [Military Statistical Review of the Russian Empire, published by the Highest Command at the 1st Branch of the Department of the General Staff. Kharkov province, according to reconnaissance and materials collected on the spot, was Gen. headquarters cap. Mochulsky]. Saint Petersburg: Typography of the General Staff, vol. 12, part 1. (in Russian)

6. Departament General'nogo Shtaba Rossiyskoy Imperii (1851). *Voennostatisticheskoe obozrenie Rossiyskoy Imperii, izdavaemoe po Vysochayshemu poveleniyu pri 1-m otdelenii Departamenta General'nogo Shtaba. Chernigovskaya guberniya po rekognostsirovkam i materialam, sobrannym na meste, sostavlyal Gen. shtaba podpolk. Mitsevizh* [Military Statistical Review of the Russian Empire, published by the Highest Command at the 1st Branch of the Department of the General Staff. Chernihiv province, according to reconnaissance and materials collected on the spot, was Gen. headquarters of the lieutenant colonel Mitsevizh]. Saint Petersburg: Typography of the General Staff, vol. 12, part 2. (in Russian)

7. Gubernskoe upravlenie statistiki (1861). *Sbornik statisticheskikh svedeniy o Kievskoy gubernii za 1859 god. S adres-kalendarem lits, sluzhashchikh v gubernii, na 1861 god* [Collection of statistical information about the Kiev province for 1859. With an address-calendar of persons serving in the province, for 1861]. Kiev: Typography of the Provincial Administration. (in Russian)

8. Tsentral'nyy statisticheskiy komitet (1858). *Statisticheskie tablitsy Rossiyskoy imperii za 1856 god, izdavaemye po rasporyazheniyu ministra vnutrennikh del Tsentral'nym statisticheskim komitetom* [Statistical tables of the Russian Empire for 1856, published by order of the Minister of the Interior by the Central Statistical Committee]. Saint Petersburg: Typography of the K. Wulf. (in Russian)

9. Tsentral'nyy statisticheskiy komitet (1863) *Statisticheskie tablitsy Rossiyskoy imperii, izdavaemye po rasporyazheniyu ministra vnutrennikh del Tsentral'nym statisticheskim komitetom. Nalichnoe naselenie Imperii za 1858 god* [Statistical tables of the Russian Empire, published by order of the Minister of Internal Affairs by the Central Statistical Committee. The actual population of the Empire for 1858]. Saint Petersburg: Typography of the K. Wulf. (in Russian)

10. Redaktsiya Podol's'kikh gubernskikh vedomostey (1859). *Pamyatnaya knizhka Podol'skoy gubernii na 1859 god* [Commemorative book of the Podolsk

province for 1859]. Kamianets-Podilskyi: Typography of the provincial government. (in Russian)

11. Golyakovskiy Ya. (1862). *Pamyatnaya knizhka Khar'kovskoy gubernii* [A memorial book of the Kharkov province]. Kharkov: University Publishing. (in Russian)

12. Dneprov E. D. (2017). *Rossiyskoe zakonodatel'stvo ob obrazovanii XIX – nachala XX veka: sb. dokumentov* [Russian legislation on education of the XIX – early XX century: Documents [Text]: in 3 volumes / ed., art., comments. E. D. Dneprov; National research University «Higher School of Economics», vol. 1]. Moscow: Higher School of Economics. (in Russian)

13. Vladimirskiy-Budanov M. F. (1884). *Universitet sv. Vladimira v tsarstvo-vanie Imperatora Nikolaya Pavlovicha* [University of St. Vladimir during the reign of Emperor Nikolai Pavlovich]. Kiev: Printing house of the Imperial University of St. Vladimir. (In Russian)

14. Bagliy D. I., Sumtsov N. F., Buzeskul V. P. (1906). *Kratkiy ocherk istorii Khar'kovskogo universiteta za pervye sto let ego sushchestvovaniya (1805–1905)* [Brief outline of the history of Kharkov University for the first hundred years of its existence (1805–1905)]. Kharkov: University Publishing. (in Russian)

15. Degtyarev S. I., Polyakova L. G., Gut J. (2020). The Social Background of Functionaries in the Russian Empire's Public Education Sector in the First Half of the 19th century: The Case of the Ukrainian Governorates. *European Journal of Contemporary Education*, vol. 9(1), pp. 212–220.

16. Makhinjko A. I. (2013). Z istoriji kadetskykh korpusiv v Ukraini [From the history of cadet corps in Ukraine]. *Storinky istoriji*, vol. 35, pp. 117–126.

17. Myl'ko V. I. (2015). Systema upravlinnja ghimnazijnoju osvitoju v Rosijskij imperiji (na prykladi ukrajinskykh mist XIX – pochatku XX st.) [Management system of gymnasium education in the Russian Empire (on the example of Ukrainian cities of the XIX – early XX centuries)]. *Problemy istoriji Ukrainy XIX – pochatku XX st.*, vol. 24, pp. 175–195.

18. Polishhuk Ju. (2012). Nacionaljni menshyny Pravoberezhzhja Ukrainy u konteksti etnichnoji polityky Rosijskoji imperiji (kinecj XVIII – pochatok XX stolittja) [National minorities of the Right Bank of Ukraine in the context of ethnic policy of the Russian Empire (late eighteenth – early twentieth century)]. Kyiv: Institute of Political and Ethnonational Studies. (in Ukrainian)

19. Kryzhanovs'jka O. O. (2011). Osvita j kul'tura ukrajinskykh seljan naprykinci XVIII – u pershij polovyni XIX st. [Education and culture of Ukrainian peasants in the late eighteenth – in the first half of the nineteenth century]. *Problemy istoriji Ukrainy XIX – pochatku XX st.*, vol. 19, pp. 243–264.

20. Pirogov N. I. (1985). *Izbrannye pedagogicheskie sochineniya* [Selected pedagogical works]. Moscow: Pedagogy. (in Russian)

21. Bodnar A. M. (2015). Osvitni transformaciji na Podilli naprykinci XVIII – v pershij polovyni XIX stolittja [Educational transformations in Podolia in the late XVIII – in the first half of the XIX century] (PhD Thesis), Kamenets-Podolsk: Kamenets-Podolsk State Pedagogical University.

**PEDAGOGICAL CONDITIONS OF PROFESSIONAL TRAINING
INTEGRATION OF SPECIALISTS IN AGRARIAN SPHERE**

Elena Levchuk¹

Natalia Havryliuk²

DOI: <https://doi.org/10.30525/978-9934-26-193-0-22>

Abstract. The research subject is future agrarians integrated professional training. Research methods: systematic references analysis; concept research; modeling; pedagogical experience generalization; scientific investigation, data analysis, discussion, students survey, diagnostic testing methods; qualitative and quantitative analyses of research results. The research purpose is to justify the pedagogical conditions for improving the integrated vocational training quality of students and to formulate the specified goals for future agrarians vocational training. It is proved that one of the promising ways for improving the training of specialists by approaching European standards is pedagogical integration. That is why interdisciplinary links of an integrative nature between the four cognitive blocks: social; mathematical; natural; disciplines related to the main branches of agriculture (crop production, animal husbandry, agricultural mechanization) are inserted into the content of training future agrarians. It is proved that under these conditions social, mathematical or professionally-oriented disciplines function as system-forming factors. The pedagogical conditions for the social, natural-mathematical and professional-oriented disciplines integration are considered as a set of interrelated circumstances of the pedagogical process necessary to create a complete training, which implementation provides training of highly qualified specialists at the lowest cost. The article describes using multimedia experience in professional training. Multimedia learning principles are considered. The possibilities of e-textbooks as a means of effective learning in

¹ Candidate of Science in Pedagogy,
Associate Professor of the Department of Mathematics, Physics and Computer Technology,
Vinnytsia National Agrarian University, Ukraine

² Candidate of Science in Pedagogy,
Associate Professor of the Foreign Languages and Translation Department,
Kyiv National Trade and Economic University, Ukraine

traditional and innovative education systems are also analyzed. Didactic requirements for the creation of this teaching tool are defined. Electronic textbooks “Higher Mathematics” and “Political Science” are presented. The introduction necessity of educational mixed and distance forms in the specialists’ professional training, according to the current social needs is justified. The interaction and integrity problem of three components such as organizational forms, didactic process and qualification of teachers is considered. The conclusion concerning the training process optimization is made, based on the undertaken generalization. The pedagogical conditions analyses for improving the quality of professional training of students allowed to formulate their main groups, such as the following: natural-mathematical, social and professionally-oriented knowledge of agricultural profile system formation on the basis of an integrative approach; problematic approach to structuring the content of education usage; information and communication technologies and multimedia means usage; formation of individual educational tendencies on the basis of educational mixed forms; distance learning introduction; focusing on the synergetic paradigm of education, which is closely related to the integration and systematization processes of the content of education, its accessibility. The research enabled to formulate the certain goals of future agrarians professional training and ,namely to master their general and special knowledge, the ability to adapt professional knowledge to the agricultural education requirements; to ensure continuity in the study of general and professionally-oriented disciplines of agricultural profile; integration of natural-mathematical, social and special agricultural knowledge and skills in professional activity; creative abilities development of agrarians on the basis of integrative, problem and activity approaches in educational process.

1. Introduction

Qualitative changes in social values and needs, significant changes in the political life and economy of the country, the growth of complex research in the scientific field, the integrative nature of production, the growth of knowledge-intensive technologies have led to new training requirements.

The diversity and openness of the economy, the variety of management forms are typical of the agro-industrial complex of Ukraine nowadays. This encourages the growth of mobility, the professional activities of specialists

creative initiative in all agricultural sector specialties, which, in turn, leads to the introduction of innovative forms, methods and content of training future professionals for professional activities. The specialists training in the agro-industrial complex is currently the subject to new requirements, one of which is the formation of such thorough knowledge that would maximize future agrarians intellectual development, the holistic system development of knowledge focused on the future agrarians' skills mastering, inclinations, preferences, social, national and professional maturity.

New approaches to training specialists that meet the above mentioned requirements are revealed.

Scientific novelty: pedagogical conditions for improving the integrated professional training students quality are theoretically described; the certain goals of future agrarians professional training are formulated; distance and mixed forms implementation of training on the basis of certain pedagogical conditions is demonstrated.

Study objectives:

1. Outline the problem of future agrarians professional training.
2. Analyze the main trends in the training process.
3. Formulate the certain goals of future agrarians professional training.
4. Identify the main cognitive blocks of disciplines in the process of training.
5. Establish interdisciplinary links of an integrative nature and determine the system-forming factor.
6. Define pedagogical conditions for the quality improvement of integrated vocational students training.
7. Develop and implement methodological materials in the practice of training specialists in mixed and distance forms.

Research methodology: systematic analysis of literature; research of the conceptual apparatus; modeling; pedagogical experience generalization; observation, data analysis, conversation, testing of students, diagnostic tests method; qualitative and quantitative analysis of research results.

Problem formulation. At present, educators are faced with the primary requirement to improve the quality of vocational education that would satisfy the current needs of society and be competitive in the global labor market.

The coronavirus pandemic has led to distant training implementation. The higher education system has entered a period of fundamental change,

characterized by a new understanding of the educational goals and values. New conceptual approaches are aimed at the use of new learning technologies and continuity of education. The objective trend of higher education institutions is to reduce the number of classroom hours and increase the share of students' independent work, non-formal and informal education. The role of the teacher in the educational process is also being transformed. The teacher's function as the main source of information is gradually losing its relevance, the teacher becomes the organizer, consultant, leader and expert of independent work of students. It requires the search for effective learning tools that would perform the following functions in the learning process: informational, formative, systematizing, controlling, motivating. Implementation of these tasks is impossible without the use of informational methods and tools.

Modern information and communication technologies are increasingly entering the educational process of higher education, becoming almost its main system-forming component that determines the educational development direction. Therefore, the priority of current education is the introduction of modern information and communication technologies that provide further improvement of the educational process, accessibility and effectiveness of education, training future professionals for professional activities in the information society.

Among the recommendations of the Second International Congress of UNESCO on Technical and Vocational Education, aimed at its advanced development, identified the introduction and active use in practice of new information technologies in educational processes.

On the other hand, young people adapt easily to the development of informatization. Due to informational technologies, modern youth perceives the universe in a new way, strive for knowledge, education, culture, creativity and work.

At the same time, these trends affect the system of higher agricultural education in Ukraine. Research and teaching staff must be able to competently select and apply exactly those technologies that correspond to the content and objectives of the study of a certain discipline, taking into account the individual characteristics of students.

With the transition to distance learning, electronic resources have created significant competition for print media, there is a problem of interaction

between traditional textbooks and information and communication technologies. Thus, questions are arisen about the status of the textbook in general, and the limits of the use of one or another form of its implementation in the form of a printed publication or multimedia educational content.

As information technology developed, new forms of information were presented. This was reflected in the content. In addition to texts and illustrations, educational content included multimedia fragments. Undoubtedly, the variety of forms of information presentation has provided new opportunities for educational resources. At the same time, this diversity has created problems related, for example, human perception limitations and special skills availability in the multimedia resources usage. The solution of these problems is hindered by the distance forms of education introduction as one of the areas of modern higher education reform and development. Therefore, information support for distance learning is one of the trends in the future professionals training. At the same time, there is the question of improving the content of traditional and developing new methods, forms and means of teaching.

Requirements are taken / into account in the result of recent reforms in Ukraine's higher educational system. Researchers raise current issues of ensuring the quality of education that would meet European requirements, but primarily adapt the Ukrainian labor market [1; 2; 3].

2. Theoretical and methodological bases of professional training integration of special-ists in agrarian sphere

Based on the approaches study of the specialists training content in agricultural higher education institutions, we have identified the following four cognitive blocks: social; mathematical; natural; disciplines related to the main branches of agriculture (crop production, animal husbandry, agricultural mechanization). By social and natural-mathematical training of an agricultural specialist we mean students' results mastering a specially selected set of elements of social and natural-mathematical knowledge, skills, abilities and values necessary for successful implementation. professional activity in the field of agriculture. We interpret professionally-oriented training as a set of disciplines that develop and supplement fundamental courses, the content of which significantly shapes the future specialists' readiness for their future professional activity. We have identified various

interdisciplinary links of an integrative nature between these blocks of disciplines. The specially fulfilled research enabled us to conclude that under above mentioned conditions, social, mathematical or professionally-oriented disciplines serve system-forming factors. Only social disciplines give the structural understanding, history and society development, and mathematically operate abstract concepts that are concretized in other disciplinary blocks. Vocationally oriented disciplines play an intermediate role between these two blocks and vocational training and act as a cross-cutting educational content component.

This gave us the possibility to formulate certain goals of future farmers' professional training, and namely, their general and special knowledge improve-ment, the ability to interconnect professional knowledge with the agricultural education requirements; ensuring continuity in the study of general and professionally oriented disciplines of agricultural profile; integration of natural-mathematical, social and special agricultural knowledge and skills in professional activity; development of agrarians' creative abilities on the basis of integrative, problem and activity approaches in educational process.

The integration of social, natural-mathematical and professionally oriented agrarians' training is a process of preparation and readiness to perform professional tasks that require integrated knowledge application, methods, apparatus of social, natural-mathematical and professionally-oriented disciplines.

After having studied and analyzed key concepts, we understand the pedagogical conditions for the integration of social, natural-mathematical and professional-oriented disciplines, as a set of interrelated circumstances of the pedagogical process that are necessary to create a holistic training.

The pedagogical conditions analysis for improving the professional training quality of students encouraged us to formulate their main groups:

- natural-mathematical, social and professionally-oriented knowledge of agricultural profile on the basis of an integrative approach formation system;
- problematic approach use to the content of education structuring;
- use of information and communication technologies and multimedia means;
- individual educational trends formation on the basis of educational mixed forms;

- distance learning introduction;
- the educational synergetic paradigm focusing, which is closely related to the integration and systematization processes of the educational content, its accessibility.

These pedagogical conditions are based on the following system-forming ideas of agricultural training integration: orientation on the educational synergetic paradigm; providing learning motivation; students` personal development realization. The above mentioned pedagogical conditions require detailed analyses.

3. Substantiation of pedagogical conditions of integration of professional training of specialists

So, one of the pedagogical conditions is the system of natural-mathematical, social and professionally-oriented knowledge of agricultural profile formation on the basis of an integrative approach.

Based on the integration term of training analysis interpretations, we have identified its procedural and effective components. We understand the integration effectiveness in professional training as a systematized set of knowledge, skills, abilities, creative experience, formed on the basis of the above mentioned blocks of disciplines, their focus on forming a future specialist holistic picture of the world, systematic thinking , the ability to solve professional problems comprehensively, to consider phenomena through all existing prisms. In other words, integration is a way to combine the necessary knowledge, skills, abilities of different disciplines, creative activity, its importance fo future farmers formation. From the procedural point of view, such processes involve forms, methods, teaching aids integration, which leads to solve professional problems as a system object with a focus on future prospects.

Since the training process is a complex nonlinear system, firstly, it is necessary to identify and characterize the integrative system-forming factors that will help to implement integration ideas more effectively.

The systematic approach implementation to the natural-mathematical integration, social and special training in agricultural institutions of higher education involves the following steps implementation: regulations analyses; directions of economic activity of agricultural enterprises study in relation to the training specialists purposes; elements analyses of the educational

content, involved in integration disciplines; establishing links between the elements of these disciplines, determining them; forms definition, methods, their demonstration means; training integration technology development; reveal the dependence of the installed system on external conditions; the quality of training assessment, which has an integrated nature.

Thus, the systematic assimilation of many facts, concepts and judgments in the study of natural and mathematical and social sciences by students is in accordance with the logical connection and rational knowledge continuity in professionally oriented disciplines, reflecting the training logic. Such knowledge integration is the basis for the holistic system of professionally significant qualities of the future specialist formation.

Using a problem-based approach to structuring learning content based on the ideas of interdisciplinary integration.

Problems in learning are the most necessary means of developing productive logical thinking, which can improve the quality of training for agriculture.

Problem-based learning is often offered to ensure professional learning motivation. This approach allows you to highlight the needs and interests of the individual, to develop tasks that most fully reveal each student's potential.

In problem-based learning process, true integration takes place, because we are not dealing with the knowledge superimposition of each other, not with their usual increase, but with their transformation and the emergence of psychological tumors in humans' basis. A number of scholars derive such a pattern of pedagogical integration levels as the relationship between the problems of learning level and its subjects integration: the higher level of problems of the educational process, the higher level of integration of those who teach and those who are taught.

Thus, the natural-mathematical, social and professional-oriented disciplines integration in the specialists' training in agricultural institutions of higher education due to the problematic way of learning gives new features to the educational process, which is a significant factor in forming professional motivation that meet all regulatory requirements for a modern specialist.

Currently, the pedagogical process priority of higher education is the information use and communication technologies and multimedia tools:

the electronic learning tools introduction (textbooks, manuals, catalogs, dictionaries, etc.), computer training programs; the knowledge rating system assessment introduction; the knowledge assessment objectivity increase. One way to solve this problem is to use the multimedia support possibilities in higher education.

The modality principle. It is based on Mayer's double coding theory: information that is presented both verbally and visually is better remembered [4].

The spatial communication principle. Students perceive information better if the words and relevant pictures are presented on a page or screen side by side, rather than separately from each other.

The temporal connection principle. If the words and the corresponding visualization are presented synchronously, not sequentially, it contributes to better learning.

The multimedia use in lectures allows you to create a visual series that helps to increase the pace of the material presentation. Multimedia allows you to use encoded information not only in the form of tables, diagrams, charts, figures but also animations. This allows students to show the dynamics of processes clearly that are difficult or even impossible to demonstrate with chalk and blackboard.

Multimedia technologies proper use in the educational process undoubtedly leads to faster understanding and new information assimilation. An example is the electronic manuals introduction [5; 6].

According to experts [7], multimedia technologies can increase 2-3 times the learning material rate, as they allow syncretic learning, simultaneously involving visual and auditory perception material, actively participating in the management of its supply, the ability to return to those sections need re-analysis.

The authors have extensive experience in the multimedia in natural sciences and mathematics use. All of them are created according to a single logical scheme.

The content of lectures in the form of an electronic manual and visualization of lectures in the form of presentations in the Pauer Point program using the mathematical package MathCad.

Practical classes methodical support, which is in the discipline card in the university network "Socrates" and contains: tasks to solve in class and homework, modular control individual tasks, training and testing tests.

Modular and final test control in the Tezaurus system.

The multimedia use in lectures allows you to create a visual series that helps to increase the material presentation pace. Multimedia allows you to use encoded information not only in the form of tables, diagrams, charts, figures but also animations. This allows students to show the dynamics processes clearly that are difficult or even impossible to demonstrate with chalk and blackboard. We widely use the MathCad system when preparing multimedia materials. This is due to the fact that if the graphic or audio information can be presented in the form of an array, then in the future for its processing you can use all the possibilities for processing MathCad data arrays (Figure 1).

One of the most interesting features of MathCad is the creation of animated sequences based on graphs. In Figure 2 the possibility of creating such an animated graphic to the above topic is demonstrated.

The multimedia use allows you to make a vivid historical digression. For example, mini-fragments of documentaries and videos presentation contributes to the semantic content of the lecture. The use of hyperlinks allows you to access the source of information directly during the lecture.

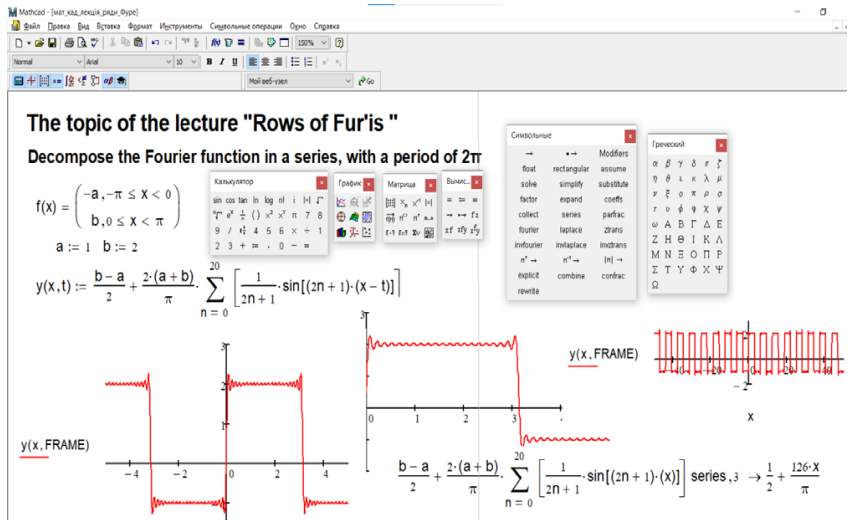

Figure 1. Data processing and visualization on the topic "Fourier series"

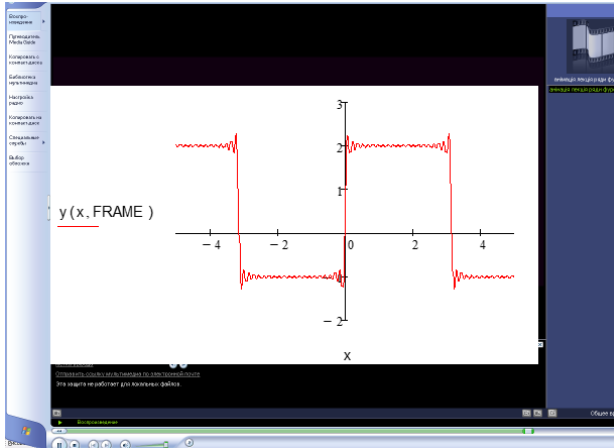

Figure 2. Creating an animated video

The lecture prepared in this way allows you to build educational material in a logical sequence, compact the material, reduce losses during the information perception related to the shortcomings of audio perception, make the most of all types of student memory: visual, motor, audio. Students can access the lecture materials at any convenient time due to the electronic data bank contained in the discipline card.

The multimedia tools use in practical classes allows you to intensify the learning process, deepen the study of educational material and improve its memorization.

Involving students in the coverage of results with the involvement of multimedia saves time to respond, gain skills in information processing, coding it in analytical form and in the form of graphics.

In addition, computer test programs allow you to create an individual version of the task instantly and process the results, increasing the time for error analysis.

Thus, we define the educational functions of multimedia:

Educational activities management;

Educational information in various forms presentation;

Training activities for the formation of various skills and abilities organization;

Educational activities control;
Communicative situation creation;
Educational process reference and information support.

Therefore, the using multimedia experience analysis in the training process allows us to identify the following benefits:

Flexibility. Ability to adjust the complex depending quickly on changes in training requirements.

Parallelism. The parallel with the traditional disciplines study. The multimedia use does not deny, but complements traditional teaching methods.

Versatility. Simultaneous access to educational information several sources (electronic libraries, data banks, knowledge bases).

Frugality. Educational areas effective use, technical means, concentrated and educational information unified presentation and multy access to it.

Manufacturability. The the latest advances use in information and telecommunications technologies in the educational space contributes to the promotion of the individual in the global post-industrial information society.

Formation of individual educational trends on the basis of learning mixed forms.

The development strategy of modern information technologies is characterized by the orientation from information to knowledge. Computer programs are knowledge carriers in the sense that they include not only information in one form or another, but also transforming information algorithms that ensure the didactic goals achievement. Methodological complexes that provide flexible individualized forms of blended learning are often used nowa-days. Profound analyses of the included information, as well as methodically and didactically sound strategy and learning algorithms allow you to enjoy the both full-time and distance learning benefits.

The optimal result is achieved due to a number of advantages of blended learning:

- focus on individual characteristics of the student;
- high-level thinking skills development according to Bloom's taxonomy;
- advantages realization of the teacher and the student partnership activity;

- decision-making using knowledge bases learning;
- personalization training support;
- productive gamification;
- mobile world of the student;
- broadband communication;
- academic integrity.

In blended learning, the personal educational environment is considered as “a set of components of the educational system obtained from the information and communication educational environment by adapting them to the goals, content and planned learning outcomes, needs and abilities of students” [8, p. 198].

Resources of blended learning contribute to the training formation individual style, maximizing the aptitudes, abilities, interests of the specialist in research activities. Under the described conditions, there are opportunities to create different conditions for learning: individual-oriented counseling, assistance in eliminating gaps in basic training, adjusting the movement depending on age, environment, subject position tendencies. Given the self-organization and self-regulation personal ways, it is possible to choose the pace, forms and methods of learning, both individual and group, both distance and classroom.

Under the described conditions, a rich active information environment is created, in which the professional socialization goal of the specialist is achieved.

Designing blended learning technology embodies a didactic system, the elements of which are the following components: target, content, methods and forms, implementation technology, testing and adjustment, analysis and forecasting. The system corresponds to the nonlinear objects structure that are subject to the system-forming factor – the target component (transition to the competency personality-oriented training model).

The target component design of and the structural elements selection is based on the study of the theoretical foundations of the problem and reasonable psychological and pedagogical conditions for the technology introduction.

The multilevel content component involves the invariant and variable components allocation and the structural and logical scheme of the course development.

After that the scientific and methodical complex of the discipline is formed, the development of forms and methods of educational and cognitive activity adequate to the semantic component is carried out, implementation technology is developed.

The didactic complex contains the discipline program, lecture notes, video lecture course, electronic manual, methodical instructions, manual of the basic course “Mathematics”, materials for use in the mode of electronic board Drawchat, presentations, information resources (test tasks, discipline card, electronic journal, repository in the Socrates system, means of control [9; 10; 11; 12].

The described technology of blended learning involves the use of electronic control system “Socrates”.

This methodological complex is both a self-study convenient tool and a multimedia educational materials modern resource for teachers. It is an element of the educational environment which includes traditional educational resources, electronic textbooks, the human factor.

Since the didactic complex is primarily focused on the possibility of its use in the blended learning system according to the individual program, it expresses the didactic open subsystem. Due to this, it can be supplemented with additional materials (specialized literature, materials for in-depth study, reference materials). For example, at the Agronomy and Forestry Department we used educational materials on mathematical statistics to process data obtained in field research, reference book “Correlation and regression analysis in Mathcad”, guidelines “Higher Mathematics: Differential Equations, Series” [13; 14; 15].

An effective resource is a set of video lectures. In this case, the inverted class principle is effective, according to which the new material assimilation by students takes place at home, and the classroom work time is allocated for consultations and problem solving.

Inverted classroom – the learning principle, according to which the new material main assimilation by students takes place at home, and classroom time is allocated to tasks, exercises, laboratory and practical research, individual teacher consultations, and answers to questions from students. The principle was proposed in 2007 to students by two science teachers, Jonathan Bergman and Aaron Sams. They started creating short video podcasts with lecture materials that students had to watch at home.

Thus, the teaching aids new generation, especially video lectures, has significantly changed the vocational education functions perception. Video content becomes not additional, but the leading means at the educational process stages, freeing the teacher from mechanical reproductive work, giving him new opportunities for for content creative search, methods, techniques, means of working with students. In the conditions of using this type of educational content, the teacher has not only the functions to teach students to use a specific source of information, but also such as dialogue, the education of getting information, advice and control during various creative tasks without which it is impossible to provide the comprehensive personality development.

However, the video course remains one of the main tools of the educational process, which is not opposed to the investor, but provides him and his students with comprehensive assistance.

Whiteboard is an effective tool for the personality-oriented distance learning implementation.

This resource allows participants in the learning process to communicate virtually, moving to active forms (dialogue, cooperation, creative learning activities), reproducing images in a joint document (board) that all participants see. The teacher can work simultaneously with a group or with individual students on different boards, making learning both individual and differentiated.

Therefore, in our work we have preferred the free web service Drawchat [16].

We use its opportunities for audio and video communication to discuss seminars, consultations, joint projects in real time. The resource allows the participant to prepare tasks in advance, save and then present in real time for discussion and addition. The service helps to integrate the content of educational information through: modeling in subject, graphic and symbolic forms.

In addition, our choice is due to a number of other organizational benefits: free; intuitive interface; registration is not required for work; to organize joint work, it is enough to send a URL to the participants; availability of webcam and microphone; ability to download PDF files and images; the ability to share on social networks and send links by QR-code.

In addition, we use MeisterTask mind maps and the Zoom platform.

For short-term simple communication in cases of situational response, in the described model we use Viber messenger.

In addition, it is effective in the classroom for commenting on lecture material, which strengthens the teacher's connection with students.

In the mixed learning context of mathematical disciplines, a wide range of opportunities arises when using a computer algebra system from the class of computer-aided design systems Mathcad.

The use of Mathcad in future agrarians mathematical training is carried out at three levels: the teacher's use of mathematical system Mathcad on classical examples demonstration, laboratory work implementation in which students learn to use computing and visual capabilities of the system independently, independent task setting based on problem approach. As a result, students, using the Mathcad system, solve professional problems that involve the knowledge integration from several disciplines and the mathematical apparatus use [17, p. 199].

The methodological complex important component is the electronic manual. Along with the widespread introduction into the educational process, there are now ambiguous interpretations of the term electronic manual. Consider some of them.

Electronic manual – a computer, pedagogical software designed primarily to present new information, which complements the printed publications, which is used for individual and individualized learning and allows for control and corrective diagnosis of the student.

An electronic textbook is an educational electronic publication with a systematic presentation of the discipline (its section, part), in which textual, audio, graphic and other information is evenly and interconnected with the help of appropriate software, which ensures the didactic cycle of learning continuity and completeness serves for group or individual training, corresponds to the curriculum and is intended for use in the educational process.

We are inclined to believe that the e-textbook is a new type of textbook that contains a complete and systematic presentation of the content of the course or part of it. The materials of the manual are arranged so that at any time you can go back or go to study additional material. The course can be studied in a computer class or at home. For each course there is an opportunity to assess their knowledge. The manual is convenient for

distance learning. An electronic textbook, as a new type of learning tool, can be an open or partially open system, ie a system that allows you to make changes to the content and structure of the manual.

The development of an electronic textbook is one of the leading areas of activity of higher education institutions mastering distance learning is the main in distance education means of learning, containing elements of any didactic system.

The main characteristics of the electronic manual are:

- multilevel and, as a result, taking into account the students individual characteristics;
- brightness, color, imagery, clarity, educational information accessibility in comparison with traditional one;
- the ability to demonstrate objects, phenomena, experiments that are not available under normal conditions;
- interdisciplinary links consolidation, rapid review of the previous material;
- easier navigation and search for material;
- a large number of training exercises. Knowledge acquisition rapid diagnosis;
- instant introduction of necessary changes and adjustments to the electronic manual, which saves costs that would be required to republish huge circulations of paper books;
- accessibility, thanks to the electronic manuals online presentation.

Thus, in contrast to the traditional electronic textbook should not only broadcast scientific facts, but above all, teach readers ways to master knowledge, their replenishment and improvement, contain the basic methodological principles of the discipline. The electronic textbook should be an intellectual self-teacher, to provide not only informational, but also motivational and cognitive functions of learning. Students must find guidelines for self-realization of their own learning opportunities and independent learning.

At the same time, the progress achieved in recent years in the introduction of electronic textbooks in the educational process requires a deep scientific substantiation of didactic and methodological bases of their use, defining the conceptual foundations of electronic textbooks, comprehensive solutions to the theory, methodology and technology.

Experience shows that electronic textbooks can be successfully used in the disciplines teaching of related to completely different knowledge fields. We propose to consider the creation and use features, developed by the authors, electronic textbooks in the disciplines of “Higher Mathematics” and “Political Science”, adapted for students of agricultural institutions of higher education.

The main stages of the electronic manual development:

1. Choice of sources.
2. Development of concepts lists content.
3. Transformation of texts in the module by sections.
4. Hypertext implementation in electronic form.
5. Development of computer support.
6. Selection of material for multimedia embodiment.
7. Visualization material preparation.
8. Material visualization.

The creation of the manual “Higher Mathematics” was carried out for the needs of didactic specialists training on the basis of modular and integrated technologies with their information support. The authors conducted a thorough comparative analysis of curricula in “Higher Mathematics” and professionally-oriented disciplines, which allowed them to find optimal ways to transform theoretical positions into practice. Practically every theoretical calculation that has an abstract character is accompanied by its practical interpretation.

The high scientific level introduction substantiates the need to study the discipline, its relevance and feasibility in the training system. The authors adhere to the correspondence of special concepts introduced into the course of mathematics, their scientific content and internal logic of mathematics. The sufficiency of the mathematical base for the consideration of professionally-oriented models is traced.

The manual is a means of forming a holistic picture of professional activity, through the use of an integrative approach to its content formation. Its peculiarity was to take into account the professionally-oriented disciplines requirements. This is due to the large interdisciplinary function of mathematics, including in agriculture. A number of its concepts have mechanical, biological, chemical, ecological, economic meaning (derivative, integral). At the same time, the manual contains many professional terms

and concepts formulated in the language of mathematics. The content of the manual is based on the fundamental principle of building mathematical models of the studied phenomena. One of his tasks is to demonstrate that the use of mathematical modeling allows a deeper, more comprehensive, more complete study of related disciplines. The manual will allow the future specialist to compare the real situations that surround him in the world with the mathematical apparatus that is offered to him in higher education.

The manual contains separate sections, which are devoted to the basics of work in the latest version of the mathematical software package Mathcad-14, tasks for independent work, modular control tasks, test tasks.

The manual is a rational, effective didactic tool in forming a holistic knowledge system and future professional skills, will promote the formation of generalized and systematized professional knowledge and skills, creative skills, increases learning motivation, is an effective tool in eliminating shortcomings in the educational process, inconsistencies in the content and chronology academic disciplines study.

The textbook “Higher Mathematics” presents theoretical material and examples of solving typical problems in the section of differential calculus of a function of one variable of the course. Each topic is accompanied by data visualization and task examples in the latest version of the mathematical software package Mathcad-14.

Thus, the created manual in the logic of variable and personality-oriented education provides a solution to the problems associated with the new requirements for the education system that is the training process qualitative improvement basis.

Studying the course “Political Science” involves mastering a certain knowledge level about the political life essence, political relations and processes. The result is the students ability to navigate in the main political schools, concepts, international political life processes, geopolitical situation, place, role and status of Ukraine in the modern political world.

The manual purpose is to give students an idea of political life, political society sphere, its development patterns, as well as the knowledge system about modern political institutions, rights and freedoms in a democratic society, types and forms of political processes, content and ways of political culture forming.

The aim of the manual is to promote the formation of students’ necessary skills and abilities to apply the modern political thinking principles to

analyze and find answers to political questions and problems facing society, and in the future to take an active part in solving modern problems of Ukrainian society progress.

The textbook “Political Science” outlines the main problems of political science at the level of their modern vision and existing political science concepts.

The publication is designed in the form of separate lectures containing theoretical material, control questions, a list of recommended reading. Each topic is accompanied by tasks for independent preparation: problem questions and tasks, topics of abstracts, test questions.

The content of the manual is based on a competency-based approach to training and is a means of active teaching methods

Summing up, we note that the electronic manual is an integral part of full-time training:

- allows you to bring to lectures and practical classes part of the material that requires visualization;
- allows independent processing of that part of the material that was outside the classroom;
- allows you to optimize the ratio of the number and content of examples and tasks that are considered in the audience and assigned to self-study;
- allows you to individualize work with students, especially the part related to homework and tests.

According to the analysis, most students in the early stages of study are well aware of the need to use information technology in their professional activities. The cognition effect is enhanced if the educational tasks are related to the practical activities of the future specialist or are of interest in his current educational activities.

Introduction of distance learning.

Distance learning is one of the promising learning technologies that plays a significant role in the modernization of education.

It is undeniable that the “generation of Google” has been involved in innovative technologies since childhood and has modern approaches to information, it has no experience of pre-network experience. Today, the Internet is the most popular source of information among others. Thus, according to a report by the non-profit organization Online Computer Library Center, about 83% of students begin to collect any information

from the search engine and only 2% pay attention to library sites or real book collections [18].

But young people are not only the future, but also the present. Thus, information technology is an integral part of its formation. This is due to the nature of the cognitive process as a reflection of human objective reality. Therefore, it is necessary to give preference to education that would provide for the worldview peculiarities of modern youth. And the task of educators at the present stage, moving to the “territory of youth”, to make the learning process thoughtful, rational, comfortable, in which the student will feel their success and intellectual ability.

Today, information technology penetrates to the depths of any professional activity, influences the style, content and methods of work, enriches it, expanding the scope. Therefore, the widespread use of new information technologies in all spheres of public life requires from the future specialist knowledge sufficient for the confident use of such technologies in their own professional activities.

But, despite the fact that a significant number of educational institutions have access to computer networks, established stereotypes often inhibit innovative development, make it impossible to perceive and implement new ideas, new techniques and technologies. One of the reasons is that such training requires universal training of teachers who have modern pedagogical and information technologies, psychologically ready to work with students in a new educational and network environment.

Therefore, the requirements of the information society for the preparation of graduates of higher education institutions for the use of modern information and communication technologies are in conflict with the lack of the necessary educational and methodological support for such training; the level of scientific achievements of computer science, psychological and pedagogical sciences contradicts their reflection in the content, methods, forms and means of teaching.

One of the areas of reform and development of modern higher education, which requires full information support, is distance learning, which is becoming increasingly popular in the world. This is one of the promising learning technologies that plays a significant role in the modernization of education. Scientists argue that the personal and telecommunication nature of learning – the main features of distance

learning (V.Y. Bykov, V.M. Kukhareno, V.A. Trainev, E.S. Polat, P.V. Stefanenko, A.V. Khutorskaya etc.). We adhere to the study of the definition of distance learning V.Y. Bykov as ensuring the provision of educational services at a distance with the help of new computer and communication technologies, universal, synthetic, integrated, humanistic form of education. Thus, the main purpose of distance learning is to provide equal educational opportunities to the population in all parts of the country through information and telecommunications.

Forms of organizing distance learning activities are diverse – from Internet conferences and webcasts of lectures to educational web forums and the like.

Today, the world's leading universities have successfully conquered the distance education market. D. Fischer pointed out several reasons for the rapid development of distance education: “1) The modern market forces us to engage in distance education, otherwise we lose – our students will go to other educational institutions. 2) The future of higher education – In the distance sector, so we need to be there in order not to fall out of the struggle. 3) We must use the intellectual property of university education wisely, as it is done in the case of patents. 4) We do it simply because we have the resources and new niches in the educational market” [19].

Many scholars define a training course as a distance course in which 80% of the training material is based on the use of on-line technologies. Currently, the world disciplines are taught in the following formats: traditional teaching, courses with network support, hybrid or mixed course, on-line course. Distance learning can take place within all types of didactic system.

Researchers argue that the personal and telecommunications nature of learning are the main features of distance learning. We adhere to the study of the distance learning definition as the provision of educational services at a distance with the help of new computer and communication technologies, universal, synthetic, integrated, humanistic form of learning.

Forms of organizing distance learning activities are diverse – from online conferences and webcasts of lectures to educational web forums and the like.

Note that the subject taught remotely has certain didactic features. This is a clear structure, which includes a methodological section, a substantive section, diagnostic and correctional blocks.

We have defined the principles of content selection in the distance learning context of the focus of the content on future professional activities; ensuring the educational tasks differentiation; the choice of ways to manage the educational and cognitive activities of students; interactivity; ensuring clarity and adequacy of educational material; feedback; structure, dynamism and variety access to educational material.

The practical implementation of these courses around the world has shown that the distance learning technologies usage requires a clear system of the discipline didactic development, structuring the curriculum, developing an interaction scheme between teacher and student, information and software support.

The subject, which is taught remotely, has certain didactic features. This is a clear structure, which includes a methodological section, a substantive section, diagnostic and correctional blocks.

The methodical block aims to give detailed instructions, teach students to work competently with a large flow of information obtained at a distance (collect facts, analyze, hypothesize, make generalizations, find alternative solutions, establish patterns, draw conclusions).

The content block is the didactic equivalent of the relevant science. We have defined the principles of content selection in the context of distance learning: the focus of the content on future professional activities; ensuring the differentiation of educational tasks; the choice of ways to manage the educational and cognitive activities of students; interactivity; ensuring clarity and adequacy of educational material; feedback; modularity and structure, dynamism and diversity of access to educational material.

But the peculiarity of distance education is, first of all, forms of learning. Recently, the material presentation in the form of video lectures (webinars) has become popular. Webinar (from webinar – web-based seminar), translated as “seminar organized on the basis of web technologies”. Webinar – interactive technology. Webinar students not only listen to and “see” the teacher and demonstration materials, but can also ask him questions orally or in writing directly in the chat during the lesson. The speaker also “sees” all participants and can ask questions to all at once or to individuals. Webinars (depending on the provider) may have an anonymity feature. The remote form of presentation of the material has a number of special requirements. The practice of conducting such classes by us allowed us to develop the main ones:

Presentation materials should be informative, but not oversaturated with information. The font should not be too small, the colors should be high contrast.

Excessive staff changes are not recommended.

If students need to explain a complex formula or material to understand what is needed to be focused and be as attentive as possible, it makes no sense to include multimedia elements in this slide of the presentation.

The attention of listeners when presenting information in this format is easily distracted. Therefore, it is necessary to change the tone of the lecture, ask questions, change the information type.

The lecturer should actively comment on the presentation material.

In turn, the multimedia technologies competent use in the educational process, undoubtedly leads to a faster understanding and of new information assimilation.

In figure 3 an element of the relevant working document is presented. You need to take into account the fact that on the computer screen this picture is moving, the viewer can instantly change the parameters, scale and view angle. In traditional teaching, this is difficult to do without technical equipment.

Outside of the lecture, as a rule, the main content of the discipline is transmitted through an electronic manual [5; 6], which contains theoretical information equipped with hyperlinks and vivid multimedia illustrations (graphics, audio and video), interactive learning models, practical tasks bank, computer laboratory work, on-line laboratory, training and testing unit, integrated with the tasks database, focused not only on working on a local computer but also on local networks and the Internet, etc.

In addition, distance learning provides the opportunity to solve problems, take tests, communicate with a virtual teacher, get advice on the Internet or, as mentioned above, communicate directly with the virtual audience on-line chatting during the webinar.

Diagnostic and correctional unit is characterized by the mechanisms presence for diagnosing the students' knowledge quality, followed by their correction. In this component, the control over the students educational activities (in terms of distance learning) is complemented by the input and output parameters study. This block provides for strict and regular reporting, which makes it impossible to help others. The criteria of this component are self-assessment of one's own abilities, ability to self-improvement taking

Chapter «Pedagogical sciences»

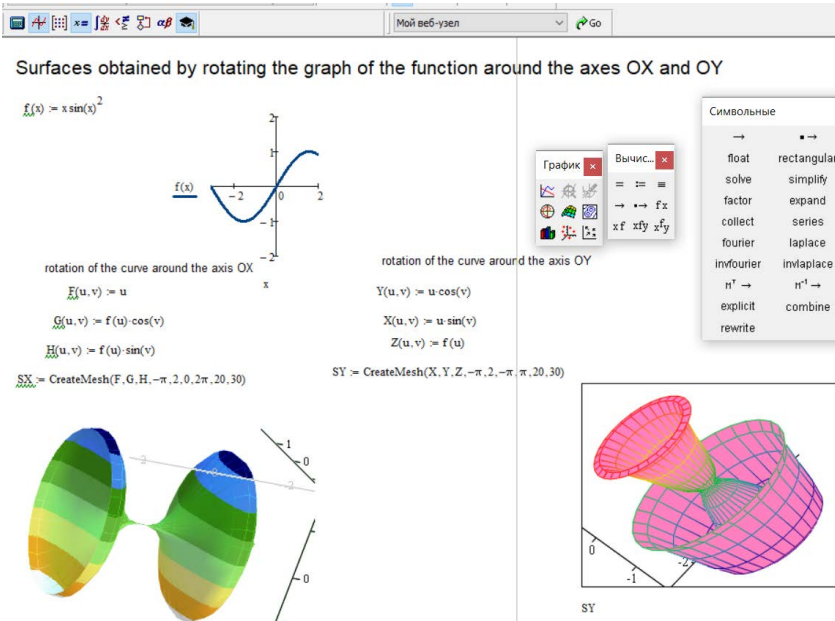

Figure 3. Visualizations on the topic: “Surfaces of rotation”

into account individual characteristics. The Ukrainian students mentality and the normative unresolved issues of organization and knowledge assessment do not yet allow to distance this unit completely.

Therefore, the teacher can use distance learning courses or their components for:

- demonstrations and illustrations of texts, formulas, unobserved phenomena;
- solving experimental problems using animation experiments;
- conducting practical and laboratory work;
- control over the level of students’ knowledge according to the methods of differentiated learning;
- current control of knowledge using modern technologies distance learning;
- computer experiment self-creation.

The main tasks of forming the qualification of teachers for distance learning include: computer technologies adaptation for distance learning; optimal theoretical material selection; the most effective forms selection, teaching methods and techniques that create the necessary conditions for information independent processing; isolation and introduction into the educational process of pedagogical conditions that contribute to the knowledge acquisition quality.

Summarizing the above, we conclude that the pedagogically justified introduction of distance learning has a number of advantages:

- time and money significant savings. Process learning will not be hindered by time factors and geographical location;

- interactivity high degree. Students are actively involved in the learning process, can ask questions, clarifying unclear points;

- methodical materials are constantly available, webinars are recorded. This allows students to develop an individual learning regime.

- strengthening the clarity and learning intensity;

- the content of the discipline instant updating;

- supplementing the content with unobserved processes and phenomena that require figurative perception;

- along with demonstration and laboratory devices and tools, use of high-quality demonstration models created on the basis of information and communication technologies of training;

- exemption from routine calculations and repetitive algorithms;

- accessibility of training for people with physical disabilities that make face-to-face learning impossible.

However, today there are a number of disadvantages:

- psychological unpreparedness and insufficient computer literacy of some students and teachers;

- conscious motivation lack, self-discipline, the self-education need in some students;

- weakening or lack of psycho-emotional contact of the teacher with the audience;

- the quality technical equipment need;

- constant control lack.

Thus, the distance forms introduction in the educational process, first of all, involves the interaction and integrity of three components: organizational forms, didactic process and teacher qualifications.

Given the above, distance learning can be said as a pedagogical technology that is based on the independent learning principle and aims at the individual creative development. A prerequisite for its effective use is high-quality information content that provides support for the learning process. Today, the educational environment of the education system of Ukraine is designed to fill the created channels with such information and provide qualitatively new conditions for the entire education system.

Focus on the synergetic paradigm of education, which is closely related to the integration and systematization processes of the educational content, its openness.

The synergetic approach makes it possible to consider any self-organizing process in the transition from chaos to order due to the internal factors of self-organization and self-government. Synergetics scientifically proves that in complex systems of any nature and any level of order, which is in an unbalanced state, weak control signals at the “input” can involuntarily increase at the “output”, leading to radical changes in the system organization.

In synergetics, mainly open systems are considered. Their essential feature is that they can be managed by changing external factors. When these essential factors are kept constant, they can be taken into account in the equations by setting the appropriate parameters constant. For example, the rate of growth of students’ knowledge is regulated externally on the basis of the relevant factors influence (content, forms, teaching methods, etc.). The evolution of synergetic systems is due to reasons that cannot be predicted with absolute accuracy. They can be partially determined by taking into account fluctuations (random deviations of the values of certain quantities from their average values). In didactic systems, fluctuations are especially important because they reflect a variety of subjective factors that “hinder” the formation of clear didactic theories and principles: individual characteristics of students, specific learning conditions, social conditions and more.

On this basis, there are three essential features of synergetic processes: correlation, self-organization, opposites oscillation (chaos – order, integration – differentiation, etc.).

4. Conclusions

Thus, the combination of integration ideas, information technologies introduction, distance education, synergy allows to consider the issue of training at a qualitatively new level. The most important, in our opinion, in the conditions we are considering, is the approach to training future professionals as an open system.

The priority steps in these pedagogical conditions implementation include: optimal theoretical material selection; the most effective forms selection, learning methods and techniques that create the necessary conditions for independent information processing, multimedia tools adaptation and computer technologies for distance learning.

Peculiarities of integrative training of specialists in an agricultural institution of higher education, due to the specifics of objects and methods of solving specific problems in the agricultural sector. These pedagogical conditions are an effective means of eliminating existing contradictions in the training farmers system, in particular, their compliance is a necessary condition for training that meets modern needs of practice.

References:

1. Talanova Zh. (2014). Aktualni problemy zabezpechennya yakosti osvity: pidsumky mynulogo roku ta plany na 2014 rik [Actual problems of quality assurance in education: last year results and plans for 2014]. *Vyshha shkola – High school*, no. 3–4, pp. 107–108.
2. Debych. M. (2014). Zavadannya vyshhoyi osvity u zabezpechenni vymog rynku praci [The task of higher education in meeting the labor market requirements]. *Vyshha shkola – High school*, no. 2, pp. 50–57.
3. Terlecaska Yu. (2014) Efektyvnist faxovoyi diyalnosti vykladachiv vyshhyx navchalnyx zakladiv: pedagogichno-psyhologichnyj aspekt [The effectiveness of teachers' professional activities of higher educational institutions: pedagogical and psyhological aspect]. *Vyshha shkola – High school*, no. 1, pp. 81–88.
4. Krokhin A. L. (2014). O kognitivnoy teorii mul'timediyynogo obucheniya R. Mayera i vzaimosvyazi verbal'noy i vizual'noy komponent lektсионnoy prezentatsii matematicheskikh distsiplin [About the cognitive theory of multimedia learning by R. Mayer and implementation verbal and pictorial layout]. *urfu.ru*. Retrieved from: <https://elar.urfu.ru/bitstream/10995/24629/1/notv-2014-105.pdf> (accessed 10 January 2022).
5. Levchuk O. V. (2020). Vyshha matematyka [Higher mathematics]. Elektronnyj navchalnyj posibnyk. Vinnyeya. *vsau.org*. Retrieved from: http://socrates.vsau.org/b04213/elbook/view_index.php (accessed 10 January 2022).
6. Levchuk K. I. (2020). Politologiya [Politicalogy]. Elektronnyj navchalnyj posibnyk. Vinnyeya.

7. Bulgakova I. V. (2012). Aktivizatsiya protsessa obucheniya s pomoshch'yu elektronnoho uchebnogo kursa dlya interaktivnogo kompleksa [The learning process activation with the help of an e-learning course for an interactive complex. *Gorizonty obrazovaniya – Horizons of education*, vol. 4(36), no. 3, pp. 80–84.
8. Slepukhin A. V. (2014). Ispol'zovanie personal'noy obrazovatel'noy sredy v protsesse individualizatsii smeshannogo obucheniya studentov [The personal educational environment implementation in the process of individualization of blended learning]. *Pedagogicheskoe obrazovanie v Rossii – Pedagogical education in Russia*, no. 11, pp. 195–205.
9. Levchuk O. V. (2019). Matematychni modelyuvannya na bazi Mathcad yak zasib formuvannya profesijnoyi kompetentnosti majbutnix ekonomistiv. [Mathematical modeling based on Mathcad as a means of the professional competence forming of future economists]. *Ekonomika. Finansy. Menedzhment: aktualni pytannya nauky i praktyky – Economics, finance, management: topical issues of science and practice activity*, no. 5, pp. 73–78.
10. Levchuk O. V. (2018). *Vyshha matematyka* [Higher mathematics]. Vinnytsya: VNAU. (in Ukrainian)
11. Levchuk O. V., Dyachynska O. M. (2019). *Vyshha matematyka (faxove spryamuvannya)* [Higher mathematics (professional direction)]. Vinnytsya: VNAU. (in Ukrainian)
12. Elektronna systema upravlinnya «Sokrat» VNAU [Electronic control system «Socrates» VNAU]. *vsau.org*. Retrieved from: <http://socrates.vsau.org/index.php/ua/pro-system> (accessed 10 January 2022).
13. Levchuk O. V., Dzis V. G., Novyczka L. I. (2016). Korelyacijno-regresijnj analiz v Mathcad [Correlation-regression analysis in Mathcad]. Vinnytsya: VNAU. (in Ukrainian)
14. Levchuk O. V., Dzis V. G., Novyczka L. I. (2016). *Vyshha matematyka: dyferencialni rivnyannya, ryady* [Higher mathematics: differential equations, series]. Vinnytsya: VNAU. (in Ukrainian)
15. Levchuk O. V., Dzis V. G., Dyachynska O. M. (2019). *Prykladna matematika na osnovi* [Mathcad. Applied mathematics based on Mathcad]. Vinnytsya: VNAU. (in Ukrainian)
16. Draw.Chat – Virtual Classroom. Retrieved from: <https://draw.chat/> (accessed 10 January 2022).
17. Levchuk O. V. (2016). *Texnologiya matematychnoyi pidgotovky majbutnix agrariyiv na osnovi zastosuvannya Mathcad* [The mathematical training technology of future agrarians based on Mathcad implementation]. *Suchasni informacijni tehnologiyi ta innovacijni metodyky navchannya v pidgotovci faxivciv: meto-dologiya, teoriya, dosvid, problemy – Modern information technologies and innovative teaching methods in training: methodology, theory, experience, problems*, no. 47, pp. 197–201.
18. Vzgljad. Delovaya gazeta (2008). Razvenchan mif o «pokolenii Google» [The myth of «Google generation» revealed]. *vz.ru*. Retrieved from: <http://www.vz.ru/society/2008/2/25/147116.print.html> (accessed 10 January 2022).
19. Douglas Fisher. *The Distance Learning Playbook*. Retrieved from: <https://www.principalcenter.com/douglas-fisher-the-distance-learning-playbook> (accessed 10 January 2022).

Izdevniecība “Baltija Publishing”
Valdeķu iela 62 – 156, Rīga, LV-1058
E-māil: office@baltijapublishing.lv

Iespiests tipogrāfijā SIA “Izdevniecība “Baltija Publishing”
Parakstīts iespiešanai: 2022. gada 25. marts
Tirāža 300 eks.